

**TM11-2087**  
**U.S. ARMY**  
**TECHNICAL MANUAL FOR**  
**KELLOGG CODE 150-E**  
**AND**  
**STROMBERG-CARLSON TYPE 106**  
**MAGNETO SWITCH BOARDS**  
**1950**

WITH CHANGE 1, 1953 AND CHANGE 2 1959



MUSEUM of TELEPHONY

Adobe Document Copyright 2008 by the JKL Museum of Telephony, Stockton, CA  
Wayne Merit, Curator

[www.jklmuseum.com](http://www.jklmuseum.com)

Adobe Document Created by Mike Neale  
Optimized for viewing with Adobe Reader 7.0 or better and web loading.



[www.telephonecollectors.org](http://www.telephonecollectors.org)



[www.atcaonline.com](http://www.atcaonline.com)

# TM11-2087

DEPARTMENT OF THE ARMY TECHNICAL MANUAL

---

## SWITCHBOARD

### SB-53( ) / FTC

NAME CHANGED TO

**SB-53/FTC      SB-53A/FTC**

PER CHANGE 1, 21 SEPTEMBER 1953

---

*DEPARTMENT OF THE ARMY • JANUARY 1950*  
*INCLUDING CHANGE 1, 21 SEPTEMBER 1953 AND CHANGE 2 20 NOVEMBER 1956*

DEPARTMENT OF THE ARMY TECHNICAL MANUAL

TM 11-2087

---

# SWITCHBOARD

## SB-53( )/FTC

---



DEPARTMENT OF THE ARMY

JANUARY 1950

---

*United States Government Printing Office*

*Washington : 1950*

DEPARTMENT OF THE ARMY  
WASHINGTON 25, D. C., 19 January 1950

TM 11-2087 is published for the information and guidance of all concerned.

[AG 300.7 (14 Oct 49)]

BY ORDER OF THE SECRETARY OF THE ARMY :

OFFICIAL :

EDWARD F. WITSELL  
*Major General, USA*  
*The Adjutant General*

J. LAWTON COLLINS

*Chief of Staff, United States Army*

DISTRIBUTION :

Tech Sv (2) except 11 (50) ; Arm & Sv Bd (1) ; AFF Bd (ea Sv Test Sec) (1) ; AFF (5) ; OS Maj Comd (5) ; Base Comd (3) ; MDW (5) ; A (5) ; CHQ (2) ; FC (2) ; Sch (2) except 11 (10) ; Gen Dep (2) ; Dep 11 (5) ; Tng Div (2) ; PE (10) ; OSD (2) ; Lab 11 (2) ; 4th & 5th Ech Maint Shops 11 (2) ; Two (2) copies to each of the following T/O & E's : 11-47 ; 11-107 ; 11-127 ; 11-500, GA, GB, GC, GD, GE, GF, GG, GH (2) ; 11-587 ; 11-592 ; 11-597 ; SPECIAL DISTRIBUTION.

For explanation of distribution formula, see SR 310-90-1.



## CONTENTS

	<i>Paragraphs</i>	<i>Page</i>
<b>PART ONE. INTRODUCTION</b> .....	1-3	1
<b>TWO. SWITCHBOARD SB-53 ( )/FTC (Kellogg Type).</b>		
<b>CHAPTER 1. DESCRIPTION AND DATA</b> .....	4-8	2
<b>2. OPERATING INSTRUCTIONS.</b>		
<i>Section I.</i> Service upon receipt of equipment.....	9-12	8
<i>II.</i> Controls.....	13-20	13
<i>III.</i> Operation under usual conditions.....	21-30	14
<i>IV.</i> Operation under unusual conditions.....	31-32	18
<b>CHAPTER 3. MAINTENANCE INSTRUCTIONS.</b>		
<i>Section I.</i> Special organizational tools and equipment.....	33-34	19
<i>II.</i> Weatherproofing.....	35-39	19
<i>III.</i> Preventive maintenance services.....	40-44	20
<b>CHAPTER 4. TECHNICAL SERVICES—FIELD AND DEPOT MAINTENANCE INSTRUCTIONS.</b>		
<i>Section I.</i> General.....	45-46	22
<i>II.</i> Theory of operation.....	47-59	22
<i>III.</i> Prerepair requirements.....	60-62	32
<i>IV.</i> Power requirements.....	63-64	35
<i>V.</i> Inspecting, stripping, and cleaning.....	65-69	35
<i>VI.</i> Trouble location.....	70-72	37
<i>VII.</i> Final testing.....	73-86	38
<i>VIII.</i> Apparatus adjustments and requirements.....	87-95	51
<i>IX.</i> Refinishing.....	96-101	58
<b>PART THREE. SWITCHBOARD SB-53 ( )/FTC (STROMBERG-CARLSON UNIVERSAL TYPE 106).</b>		
<b>CHAPTER 5. DESCRIPTION AND DATA</b> .....	102-106	60
<b>6. OPERATING INSTRUCTIONS.</b>		
<i>Section I.</i> Service upon receipt of equipment.....	107-108	65
<i>II.</i> Controls.....	109-113	69
<b>CHAPTER 7. MAINTENANCE INSTRUCTIONS.</b>		
<i>Section I.</i> Special organizational tools and equipment.....	114-115	70
<i>II.</i> Weatherproofing and preventive maintenance services.....	116-117	70
<b>CHAPTER 8. TECHNICAL SERVICES—FIELD AND DEPOT MAINTENANCE INSTRUCTIONS.</b>		
<i>Section I.</i> Theory of operation.....	118-129	71
<i>II.</i> Prerepair procedures, power requirements, and inspecting, stripping, and cleaning instructions.....	130-132	78
<i>III.</i> Trouble location and final testing.....	133-143	78
<i>IV.</i> Apparatus adjustments and requirements.....	144-146	88
<b>APPENDIX I. SHIPMENT AND STORAGE</b> .....		91
<b>II. REFERENCES AND IDENTIFICATION TABLES OF PARTS</b> .....		92
<b>III. DEMOLITION TO PREVENT ENEMY USE</b> .....		96
<b>INDEX</b> .....		97

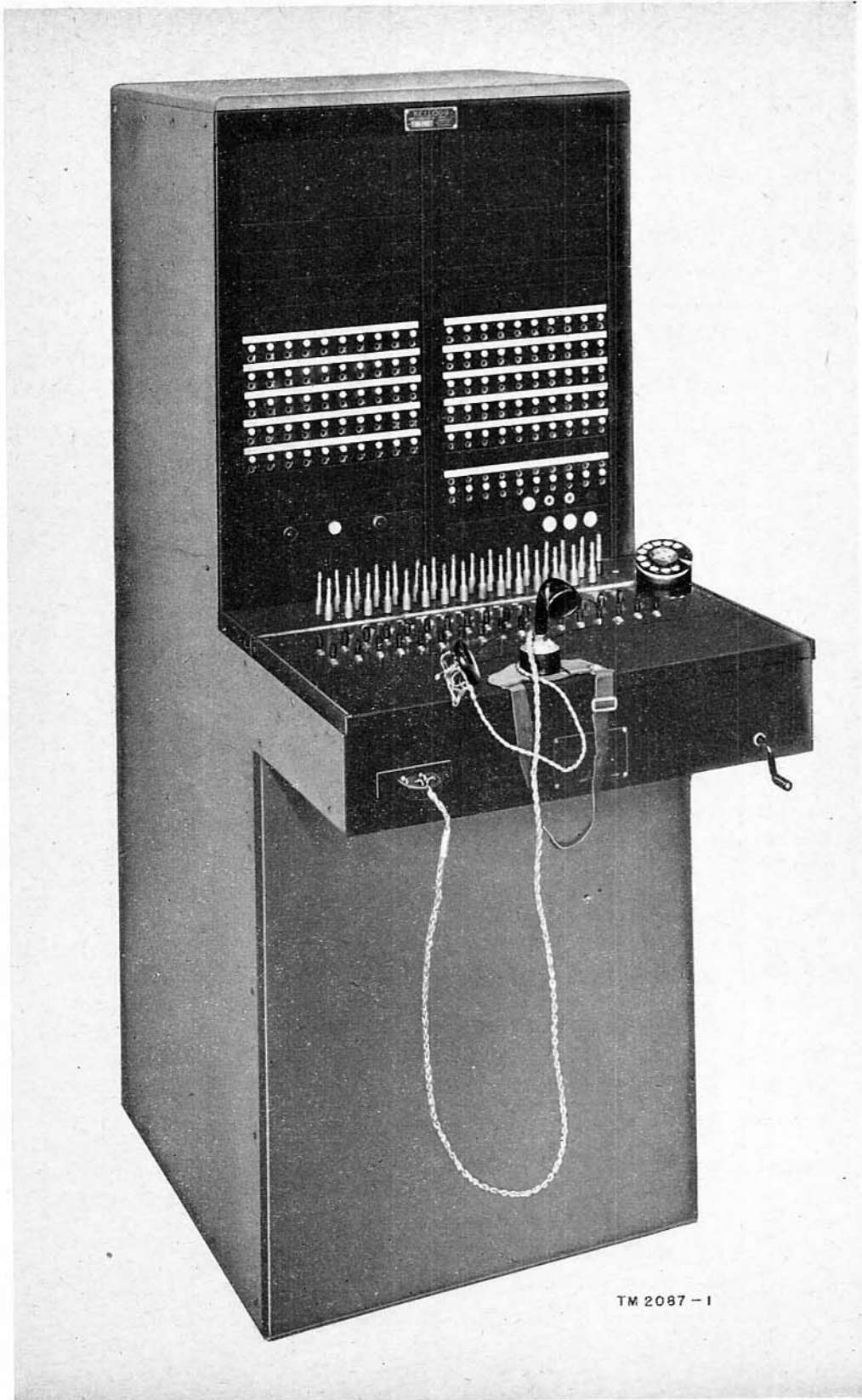

TM 2087 - 1

Figure 1. Switchboard SB-53( )/FTC (Kelllogg type).

# PART ONE

## INTRODUCTION

---

### 1. Scope

*a.* These instructions are published for the information and guidance of the personnel to whom this equipment is issued. They contain information on the installation, operation, maintenance, and repair of the equipment as well as descriptions of the major units and their functions in relation to other components of the equipment. They apply to two commercially built units which meet the requirements of Switchboard SB-53( )/FTC: the Kellogg universal type switchboard and the Stromberg-Carlson universal type 106 switchboard.

*b.* This manual is written in three parts. Part one contains introductory matter, part two covers the Kellogg type of switchboard, and part three covers the Stromberg-Carlson type.

*c.* The switchboards perform like functions, although individual circuit arrangements and mechanical details differ. Differences in the circuit arrangements and mechanical details do not affect interchangeability of the switchboards, but they do affect the exchange of component parts of each.

### 2. Forms and Records

*a.* The following forms are used in reporting receipt, operation, and maintenance of the equipment:

- (1) NME Form 6 (Report of Damaged or Improper Shipment) for equipment used by the Army will be filled out and for-

warded in accordance with AR 700-30 or AFR 67-5, when equipment is received in a damaged condition or when it is necessary to report unsatisfactory preservation, packaging, packing, marking, loading, unloading, and handling of supplies.

- (2) DA AGO Form 468 (Unsatisfactory Equipment Report) for equipment used by the Army will be filled out and forwarded through channels to the Office of the Chief Signal Officer, Washington 25, D. C., when trouble occurs more often than is normal, as determined by qualified repair personnel.
- (3) AF Form 54 (Unsatisfactory Report) for equipment used by the Air Force will be filled out and forwarded to Commanding General, Air Matériel Command, Wright-Patterson Air Force Base, Dayton, Ohio, in accordance with AF Regulation 15-54.

*b.* Use other forms and records as authorized.

### 3. References

This manual contains three appendixes. Appendix I pertains to shipment and storage instructions; appendix II contains references to other sources of information and the identification tables of parts; and appendix III includes instructions for the demolition of this equipment to prevent its use by the enemy.

**PART TWO**  
**SWITCHBOARD SB-53( )/FTC (Kellogg Type)**

**CHAPTER 1**  
**DESCRIPTION AND DATA**

**4. General**

*a.* Switchboard SB-53( )/FTC (Kellogg type) (fig. 1) is a single-position, manually operated, cord-type universal switchboard designed for use at fixed installations for connecting locally associated common battery and magneto telephones as well as for originating and terminating calls to other switchboards.

*b.* This type switchboard provides 110 lines. One hundred of these lines are used for locally associated telephones; the other 10 are for trunk lines. Fifteen talking connections can be made through the switchboard simultaneously.

*c.* Provided with the switchboard is an operator's telephone set and a magneto ringing generator, the latter of which is built into the switchboard. A separate power ringing generator can be used but is not furnished with the switchboard.

*d.* A 24-volt d-c (direct-current) power supply (storage battery) is required for operation of the switchboard. This battery, as well as an operator's chair, must be furnished by the using organization. They are not supplied with the switchboard.

*e.* Whether Switchboard SB-53( )/FTC is used as a branch exchange in a central office or as a small main exchange, it is likely that there will be associated with it, for its efficient operation, a rectifier for keeping the battery charged and a frequency converter for regulation of ringing current. The power source is ordinarily any 110-volt source of ac (alternating current) for operation of the rectifier. In the sections of this manual covering preoperational and operational procedures it is assumed that such associated equipment is maintained in efficient operating condition by qualified maintenance personnel.

**5. Weight and Dimensions**

*a.* The information below applies to the switchboard unpacked and ready for installation.

Unit	Height (in.)	Width (in.)	Depth (in.)	Weight (lb)	Volume (cu ft)
Switchboard SB-53( )/FTC (Kellogg type)----	59	24	38 $\frac{3}{4}$	550	31.5

*b.* Furnished with each switchboard is a tool roll, a set of drawings, a carton of maintenance parts, and a carton of unassembled parts. Also issued with the switchboard is an operator's telephone set.

**6. Packaging Data for Export Shipment**

*a.* PREPACKAGING SWITCHBOARD.

- (1) Remove the rear panel of the switchboard.
- (2) Tie all hanging cords with web strapping or with cotton tape, and secure the cords within the cabinet.
- (3) Block and brace in place, as required, all interior components within the switchboard cabinet with cells and/or pads fabricated of corrugated fiberboard.
- (4) Tie the components, as required, to prevent shifting.
- (5) Replace and secure the rear panel.
- (6) Cushion the dial, switches, cords, and all sharp projecting equipment mounted on the switchboard shelf by wrapping with neutral cellulose wadding, securing the cushioning with pressure sensitive tape.
- (7) Wrap the switchboard in a blanket of neutral cellulose wadding, 1 inch thick, securing the blanket with pressure sensitive tape or cotton tape.
- (8) Design and fabricate wooden blocking frames of exact dimensions to fit under the switchboard shelf, and from the top of the shelf to the top of the switchboard.

- (9) Assemble the blocking frames so that they will meet the front face of the operator's table neatly; then, square the assembly.
- (10) Cover with felt all surfaces of the block frames contacting the switchboard.
- (11) Design and construct a wooden mounting base to receive the switchboard in a vertical or operational position. The framing timbers should be of adequate cross-sectional dimensions, determined by the weight of the equipment. The mounting base should have a minimum of six bolt holes to receive the mounting bolts.
- (12) Position the prepackaged switchboard on the mounting base. Secure the switchboard to the mounting base with four end-threaded anchor rods,  $\frac{3}{4}$ -inch diameter, and with adequate structural angle iron hold-downs placed over the top of the switchboard and blocking frame.
- (13) Secure the package holding unassembled parts, etc., within the lower blocking frame with flat metal strapping.
- (14) Position the blocking frames under and over the switch shelf, and secure, as required, with flat metal strapping.
- (15) Position the drilled angle iron hold-downs over the switchboard top and anchor rods, and place lockwashers over the anchor rods; then turn bolt nuts down firmly. To securely anchor the switchboard in position during transit, strap the switchboard to the base.

**b. PACKAGING SWITCHBOARD.**

- (1) Fabricate the components of a nailed wooden box conforming to the requirements of specification JAN-P-106, modified to include a skid type base and interior diagonal bracing. The number and size of cleats and interior bracing members are determined by limitations of weight and volume.
- (2) The boards forming the face parallel to the skids should run vertically, and a minimum clearance of 2 inches should be maintained between the sealed barrier and the sides, ends, and top.
- (3) Drill bolt holes through the skids and base of the box to match the bolt holes of the mounting base. Insert bolts of suit-

able style and size through the box skids and base. Assemble in order: a waterproof barrier, conforming to requirements of specification JAN-P-125 for case liners; a moisture-vaporproof barrier, qualified for class A application and conforming to specification JAN-P-131, and suitable gaskets over the mounting bolts.

- (4) Caulk around bolts and gaskets with suitable cement, and position a heavy single-faced, flexible, corrugated, cushioning shroud over the bolts and barriers.
- (5) Position the mounted switchboard over mounting bolts. Place lockwashers over bolts, and bolt nuts down firmly.
- (6) Cushion all sharp projections and sharp corners of the mounted switchboard assembly by covering them with pads of flexible, corrugated paper, securing the cushioning with gummed Kraft tape or cotton tape. Secure the required amount of desiccant to the switchboard.
- (7) Close and properly seal the barriers. Secure the packaged technical manuals which apply to the switchboard to the top side of the waterproof barrier with gummed Kraft tape.
- (8) Indicate on the packing case the date the switchboard is packaged, the approximate weight, the length, depth, height of the packing case, and its volume in cubic feet, approximately 66.

**7. Description of Switchboard Unit (figs. 1, 2, and 3)**

The cabinet of this switchboard contains, or has mounted within it, all parts of the Kellogg universal switchboard. An operator's telephone set is provided separately. The switch shelf is low enough to allow an operator to use any available chair in connection with the operation of the board.

**a. FRONT OF SWITCHBOARD.**

- (1) Five each designation, line jack, and line lamp strips are mounted in rows on each of two upright panels on the face of the switchboard. Each lamp is located above its associated line jack. There are 10 jacks mounted on each line jack strip; likewise, 10 lamps are mounted on each line lamp strip.



- (2) At the bottom of the right-hand panel are four additional strips. The topmost of these four strips is the trunk designation strip, the second is the trunk dial jack strip, the third is the trunk line lamp strip, and the fourth is the trunk line jack strip.
- (3) Below the trunk line jacks are two cord test jacks marked CB and MAG, and a plunger-type switch marked T. These are used for testing the cord circuits in either magneto or common battery opera-

tion. To the left of the common battery cord test jack is a line pilot lamp associated with the 50 line jacks and the 10 trunk line jacks on the right-hand panel. Below a group of line jacks on the left-hand panel are three pilot lamps. The first of these is the fuse alarm pilot lamp, the second is the line pilot lamp for the group of 50 line jacks on the left-hand panel, and the third is the night alarm pilot lamp.

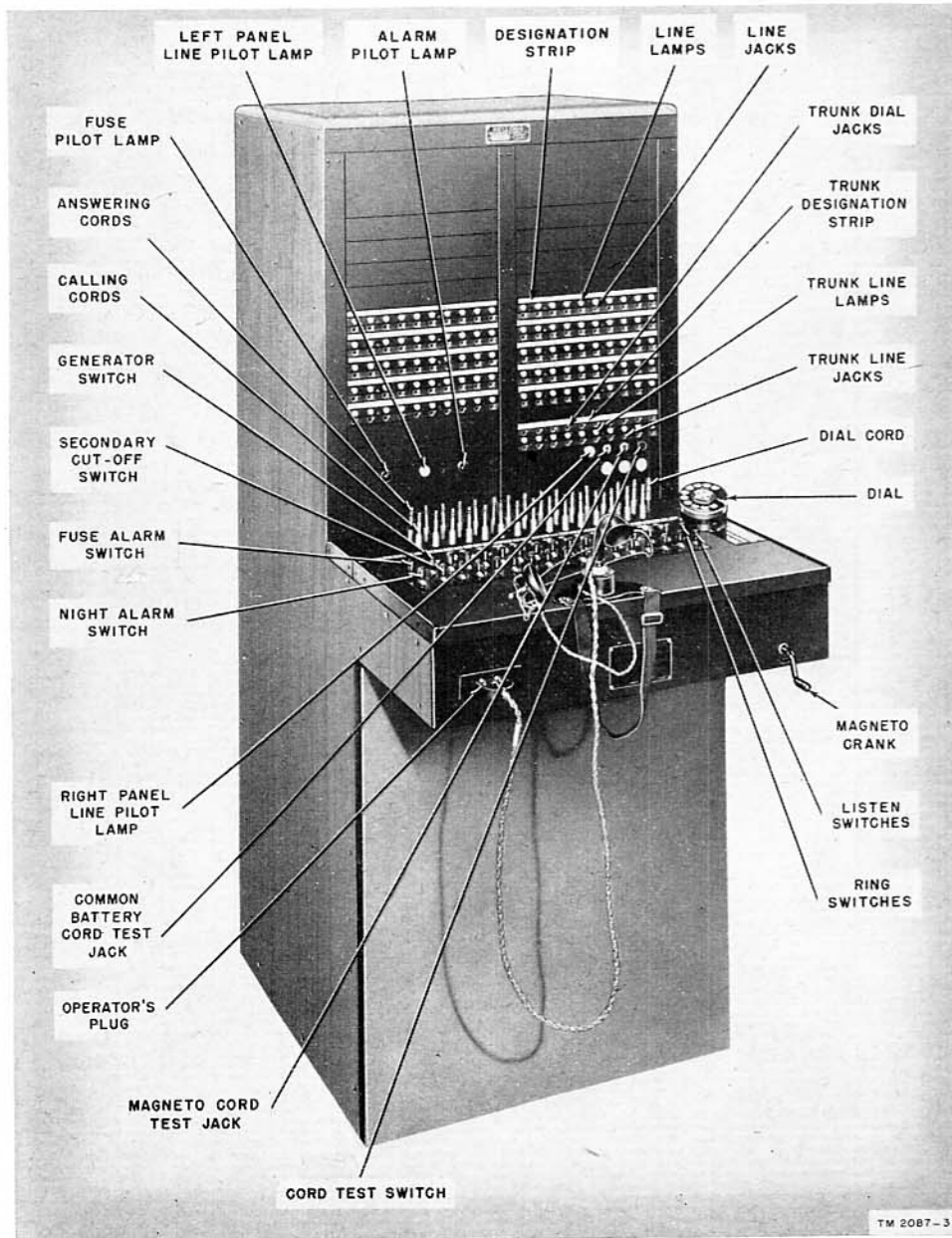

Figure 2. Switchboard SB-53 ( )/FTC (Kellogg type), front view.

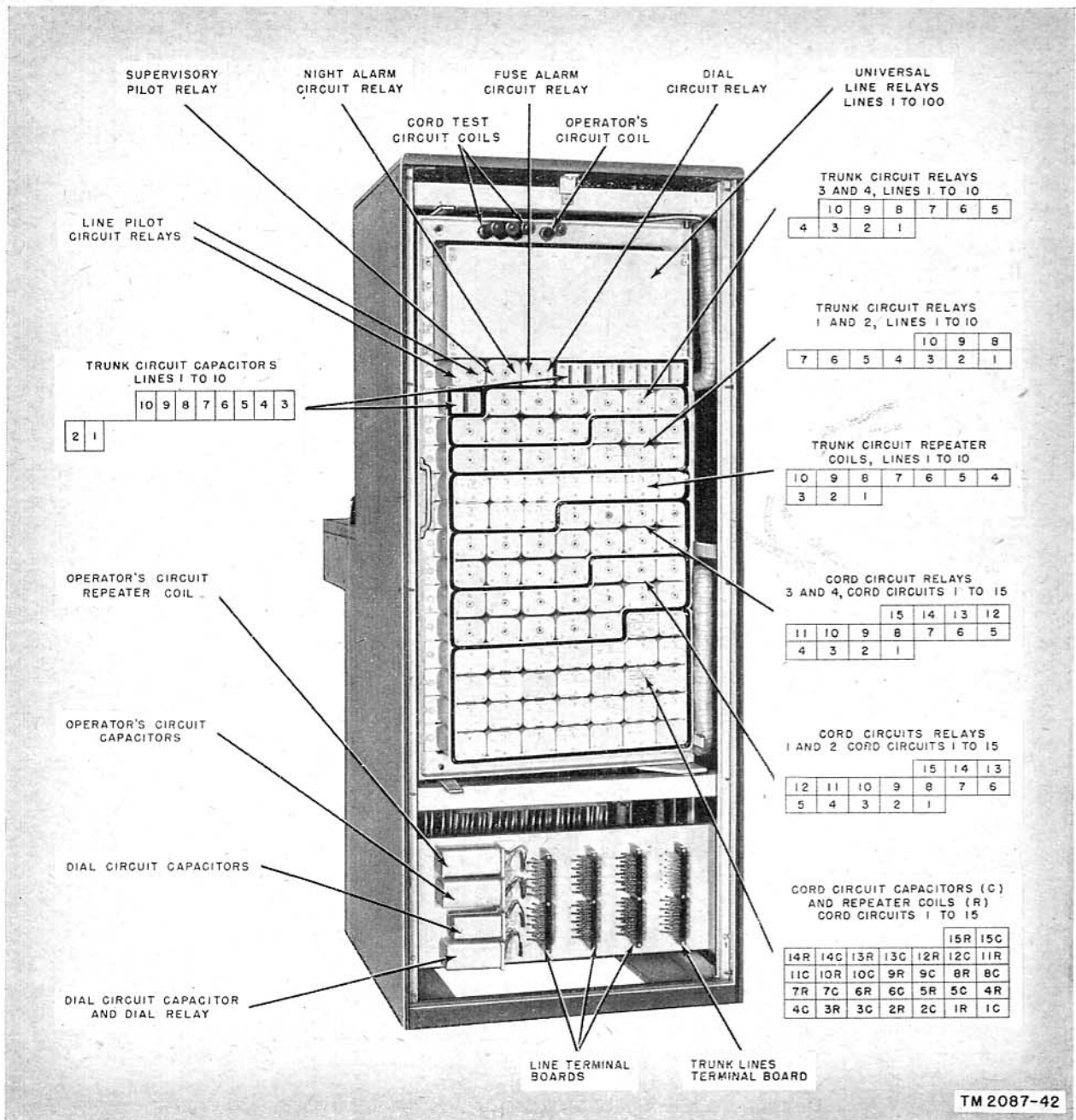

Figure 3. Switchboard SB-53( )/FTC (Kellogg type), rear view.

(4) Two rows of answering and calling cords (15 cords in each row) are located at the rear of the switch shelf. On the right-hand side of the shelf is a single black dial cord (fig. 2) identified by the letter D. This cord provides a means of completing a dial circuit for outgoing trunk calls. On the hinged part of the shelf, in line with the cord pairs, are two rows of super-

visory lamps, arranged with 15 lamps in each row. Lamps in the rear row are the answering cord supervisory lamps, those in the front row are the calling cord supervisory lamps, and each lamp has its respective cord.

(5) A row of 15 ring and ring-back switches and a row of 15 listening switches are mounted as pairs on the switch shelf in

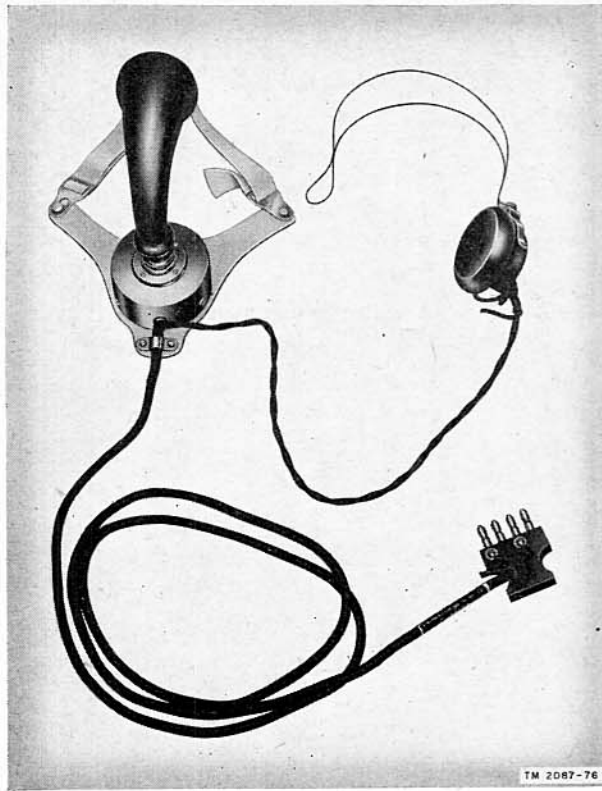

Figure 4. Operator's telephone set furnished with Switchboard SB-53( )/FTC (Kellogg type).

line with their associated lamps and cords. To the left of these switches are the fuse alarm switch marked FA, the generator switch marked GEN SW, the night alarm switch marked NA, and the secondary cut-off switch marked SEC CO.

- (6) A dial is mounted on the right-hand side of the shelf (fig. 2). The hinged portion of the shelf opens to permit access to the wiring for the switches, the switch contacts, and the lamps.
- (7) A jack for the operator's telephone set is mounted on the left front edge of the shelf. The shaft of the magneto ringing generator extends from an opening in the right-hand front edge of the shelf. A hand crank, provided in the carton of un-assembled parts, connects to the end of the shaft.

b. REAR OF SWITCHBOARD.

- (1) A full length wooden panel at the rear of the switchboard (fig. 3) can be removed to gain access to the relay gate. To remove it, lift it upward and outward at the bottom. This gate contains the

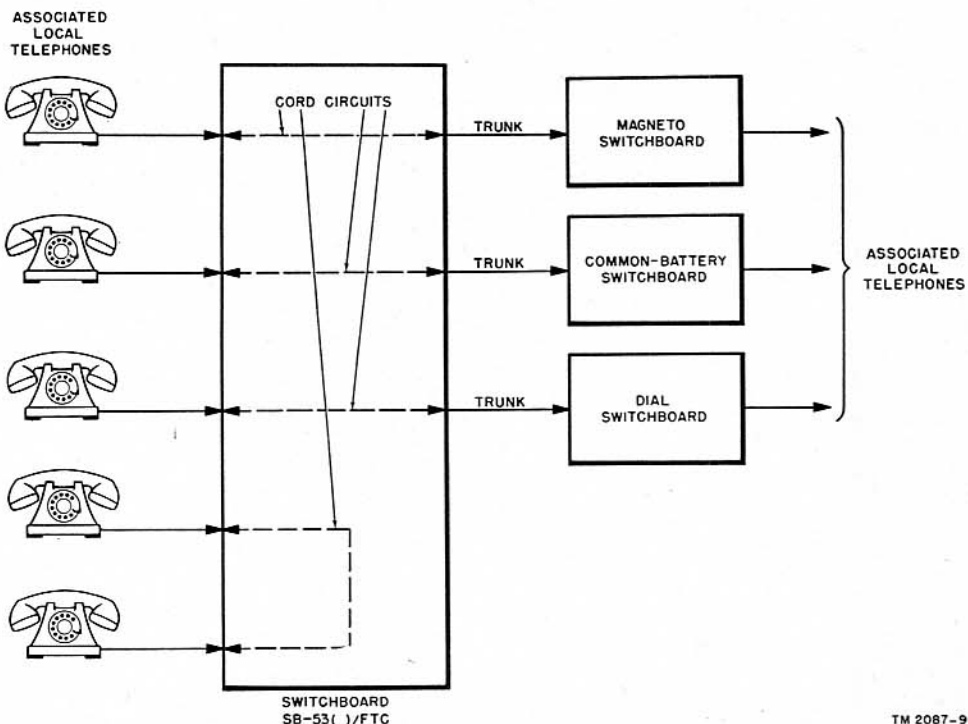

Figure 5. Switchboard SB-53( )/FTC, possible connections, block diagram.



line and cord circuit relays, the trunk relays, and their associated coils and capacitors. All of these, with the exception of four coils at the top of the relay gate, are covered by can-type dust covers. Three of these four coils are for the cord test circuit, and the fourth is for the operator's circuit. All coils are held in place by hexagonal nuts threaded on studs attached to mounting strips on the relay gate.

- (2) Four line terminal boards (three for local telephones and one for trunk lines), the operator's circuit repeating coil, capacitors for the operator's circuit and the dial circuit, and the dial relay are mounted on the wooden panel below the relay gate.
- (3) Access to the cords, the cord terminal shelf, the night alarm bell, connections to the jack and lamp strips, the ground and ringer connections, the fuse panel, and the generator resistance lamp is made possible by the removal of two screws located on the left-hand side of the relay gate.

*c.* OPERATOR'S TELEPHONE SET. The operator's telephone set (fig. 4) consists of a transmitter and breastplate, a receiver and headband, and a cord set terminated in a four-prong plug.

## 8. Application of Equipment

*a.* Switchboard SB-53( )/FTC is designed for use in either a small central office as a branch exchange or as a small main exchange. This type of switchboard provides facilities for interconnection of 100 local lines and 10 trunk lines. The 10 trunk lines provide trunking facilities for the 100 local lines to any magneto, common battery, or dial exchange (fig. 5).

*b.* Switchboard SB-53( )/FTC is equipped with the following features: direct dialing of trunk circuits, supervisory and pilot lamps, an operator's telephone circuit, a night alarm circuit, a cord test circuit, and a magneto generator ringing circuit.

*c.* The Kellogg universal type switchboard is provided with a fuse alarm circuit to give visual and/or audible (as applicable) indication of a blown fuse.

## CHAPTER 2

### OPERATING INSTRUCTIONS

---

#### Section I. SERVICE UPON RECEIPT OF EQUIPMENT

##### 9. General

Instructions covering service of the equipment on its receipt are the same whether the equipment is new or whether it has been reconditioned. Locate the switchboard in a building that is dry and that can be kept at a comfortable temperature for the operator. The building should be where a good ground connection is available and where lines can be conveniently terminated in the switchboard. A basement will facilitate the lead-in. The room in which the switchboard is located should be as free of dust and dirt as is possible.

##### 10. Unpacking and Visual Inspection

*a. SITING.* Place the crated switchboard as close as possible to the point where it is planned to install it. Such siting will reduce the chance of damage and eliminate the possibility of foreign matter entering the equipment when it is moved to its final site. Cut the steel straps and remove the screws or nails from the sides and top of the crate. Do not pry the boards off the crate. Carefully cut and remove the moistureproof paper inclosing the switchboard. Stand the equipment in place and remove the rear panel of the switchboard. Unscrew the two bolts at the left top and bottom edge of the relay gate, to open and remove any internal packing. To remove strain from the cord terminals (fig. 6), remove the lashing used to secure the cords, and check each cord to see that it is hooked to the clips at the rear of the cord terminal shelf.

*b. UNPACKING.* Handle the equipment carefully, when unpacking, to prevent damage to components or to prevent infiltration of dust and dirt which affects the operation of the equipment.

*c. CHECK AND VISUAL INSPECTION.* Check the equipment against the shipping list to determine that all components and parts have been received. Inspect the entire switchboard for evidence of damage that may have occurred in transit. Check especially for loosened can covers on the relay gate

(fig. 6), and for damaged switches on the switch shelf (fig. 2).

##### 11. Installation of Switchboard SB-53( )/FTC (Kellogg type)

###### *a. LOCATING THE BOARD.*

- (1) Locate and mark the floor site for the switchboard. Plan the installation so that there will be at least 24 inches of clearance on all sides of the switchboard to provide ample room in which maintenance personnel may work. Make sure that the switchboard is level, and that the arrangement will insure that the operator will have good lighting.
- (2) Open a 6-inch hole in the floor and install a sleeve in the hole to cover any roughness that may damage the wires which will be brought through into the switchboard. Place the switchboard in position and fasten the switchboard to the floor with angle irons. Remove the rear panel and open the relay gate (fig. 6).

###### *b. EQUIPMENT CONNECTIONS.*

- (1) It is important that the equipment be well grounded. The type of exchange in which the switchboard is to be used will have a bearing on the manner in which grounding is accomplished. Refer to TM 11-474 and TM 11-676 for general and specific instructions for grounding, and to TM 11-676 for arrangement of protective equipment.
- (2) Pull the lead-in wires or cable through the floor. Clip the wires, leaving approximately 3 feet for connections to be made to the terminal boards within the switchboard. Clamp the leads or cable at the floor to relieve any future strain on the terminal connections. These wires are to be soldered to the terminals at the terminal boards within the switchboard

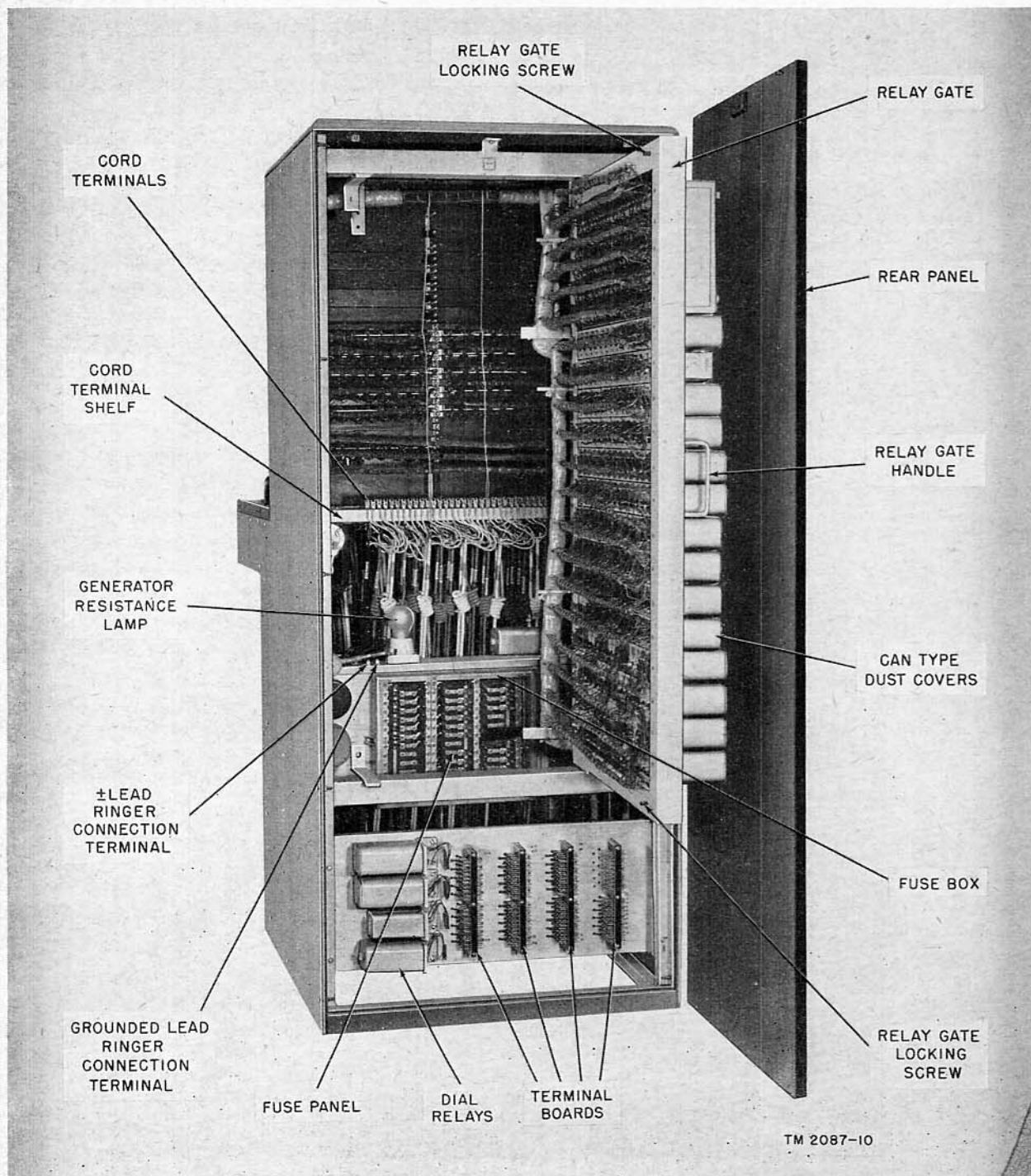

TM 2087-10

Figure 6. Switchboard SB-53( )/FTC (Kellogg type), relay gate open.

after their identification, according to instructions given in paragraph 12.

*Note.* It is practicable to bring lines into the switchboard by means of lead-covered cable. Entrance to the building which houses the switchboard may be either by aerial cable or underground cable as described in TM 11-2263. The type of cable and the method of terminating the cable on the switchboard terminal boards is described in TM 11-372.

- (3) Terminal boards within the switchboard are designated A to D, from right to left (fig. 7). Board A accommodates the 10 trunk lines; board B, the associated telephone line Nos. 1 through 40; board C, line Nos. 41 through 80; and board D, line Nos. 81 through 100. Groups of holes beside each terminal board are numbered to identify line pairs to be inserted in them.
- (4) Identify each pair of wires and fan them out along the bottom of the fanning board, behind the terminal boards.

Bring the wire pairs for line Nos. 1 and 21 through the lowest outside hole next to terminal board B, stamped 1-21.

- (a) Connect the pair for line No. 21 to the terminals at the bottom rear of the board by winding each wire around its terminal.
- (b) Connect one wire to the tip terminal and the other to the ring terminal (fig. 8).
- (c) Connect the wire pair for line No. 1 to the outer pair of terminals at the bottom of the board. Then start at the bottom rear and connect line No. 21, then connect line No. 22 above line No. 21, line No. 23 above line No. 22, etc., until line No. 40 has been connected. Follow by attaching line No. 2 to the outer pair of terminals above line No. 1, line No. 3 above line No. 2, and so on until line No. 20 has been connected.

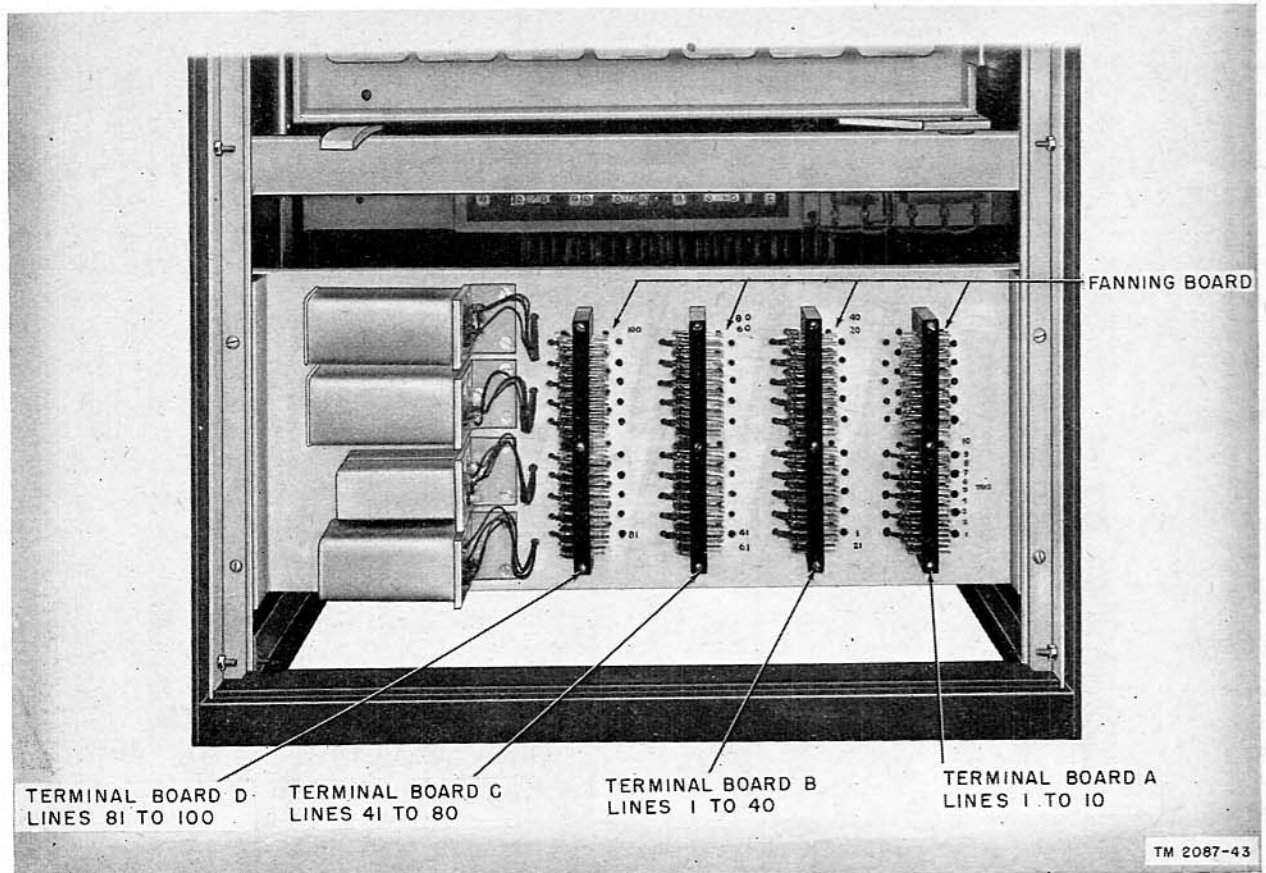

Figure 7. Switchboard SB-53 ( )/FTC (Kellogg type), fanning and terminal boards.



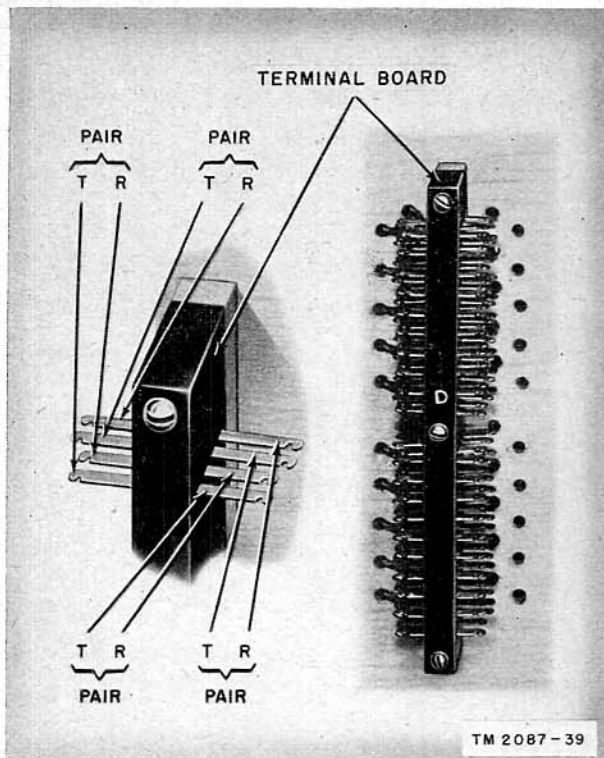

Figure 8. Switchboard SB-53( )/FTC (Kellogg type) terminal board, showing tip and ring connections.

- (5) Attach the pairs for the trunk lines to the outer row of terminals on terminal board A, starting at the bottom with trunk line No. 1. For additional information, refer to the wiring diagram provided with the switchboard.
- (6) After all wire pairs have been attached, arrange them neatly behind the fanning board and lace them tightly into cables in the conventional manner, using waxed lacing cord. Unwind each lead from its terminal and solder as directed in paragraph 12.
- (7) After all wires have been connected, remove the glass fuse box cover on the connecting rack (fig. 9) by releasing the snap clips. Remove the fuse carton from the carton of unassembled parts. There are five 3-ampere fuses indicated by blue beads, two of which are supplied to the line pilot circuit, and one each to the fuse alarm circuit, the operator's circuit, and the night alarm circuit. Also within the carton are twenty  $1\frac{1}{2}$ -ampere fuses provided for the remaining circuits. Loosen the terminal screws on the adjacent fuse

bars, insert the fuses between the washers and reset the screws. Be sure that the fuses are positioned so that the springs in the rear will contact the fuse alarm bar if a fuse blows.

- (8) Connect the 24-volt d-c power supply to the switchboard as shown in figure 10. Attach the negative battery lead to the terminal screw at the top of left-hand battery bar A, and the positive lead to the terminal screw at the top of battery bar B.
- (9) Remove the lamps and lamp caps from the carton of unassembled parts and install one lamp in each receptacle. Insert the small white lamp caps over the line lamps. Install the large green lamp caps over the fuse alarm pilot lamp (fig. 2), and install the two large white lamp caps over the line pilot lamps (fig. 2). Place the small red, white, and green lamp caps over the supervisory lamps on the cord shelf. Colors will correspond to the matching colored cord sets.
- (10) Remove the magneto hand crank (fig. 2) from the carton of unassembled parts and attach it by screwing it to the magneto shaft at the right front edge of the switch shelf. The shaft is threaded to screw into the crank hub in a clockwise direction.
- (11) If an external power ringing generator is to be used, connect the leads to the short terminal bars on the top of the connecting rack (fig. 6). Be sure that the grounded lead is attached to the right-hand bar.
- (12) Remove the operator's telephone set from the unassembled parts carton, and insert the plug into the jack at the left front of the shaft.
- (13) Remove the 15-watt lamp from the carton containing the unassembled parts, and screw it into the generator resistance lamp socket (fig. 6).
- (14) The Kellogg switchboard 561-A line relay (fig. 10) may be wired for common battery or magneto operation, depending upon the type of telephone used on the line. The two types of wire connections are shown in the diagrams in figure 10. Check the relays to establish the type of

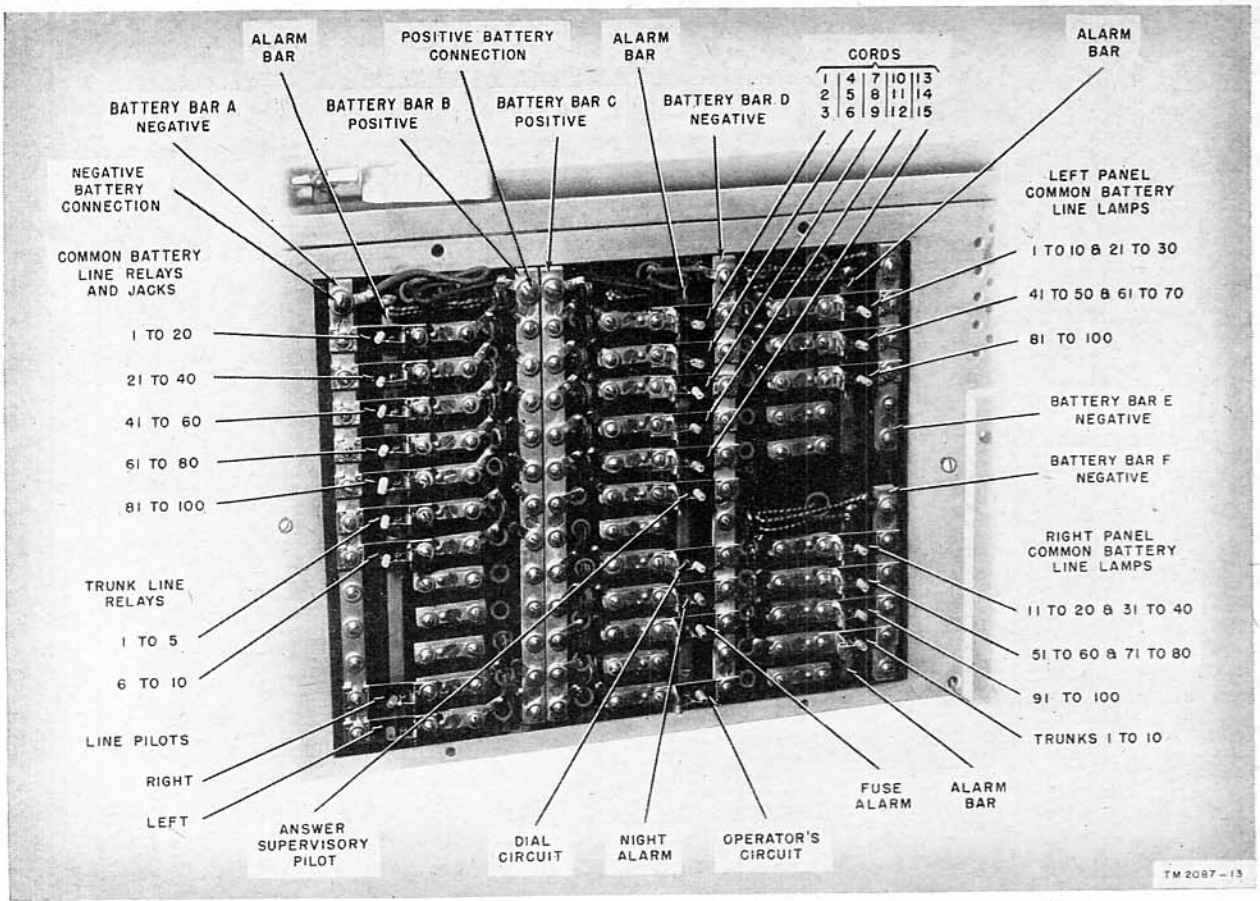

Figure 9. Switchboard SB-53 ( )/FTC (Kellogg type), fusing and power connections.

service for which they are wired, and if a change is indicated, follow the instructions given in (a) and (b) below.

- (a) To change from magneto to common battery operation (A to B, fig. 10), move the blue wire from terminal 2 to terminal 3; move the black wire from terminal 6 to terminal 4.
- (b) To change from common battery operation to magneto (B to A, fig. 10), reverse the procedure given in (a) above.

- (15) Trunk circuits in the Kellogg switchboard are universal and no change in the wiring is required for either common battery or magneto operation.

## 12. Soldering Line Leads to Terminals on Switchboard Terminal Boards

a. Straighten each lead and strip the insulation from a short distance behind the point of contact with each terminal. Clean the exposed portion of each wire thoroughly and bring the leads forward

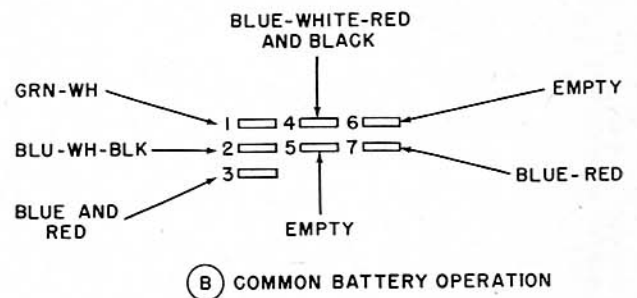
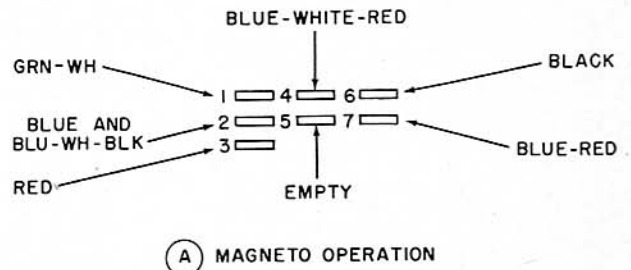

Figure 10. Kellogg line relay connection diagrams, spring relay numbering of 561-A line relay as viewed from terminal end.

under each row of terminals. Wrap each wire around its proper terminal once and clip away any excess length. Use resin core solder whenever possible; however, if acid core solder, soldering paste, or liquid flux is used, clean the connection carefully with carbon tetrachloride after soldering to remove any corrosive deposit.

*b.* Apply a clean, well-heated, properly tinned soldering iron to the joint and allow it to heat thoroughly. Then apply solder directly to the

connection and permit a small quantity to flow well into the joint. Remove the iron from the joint, and when the joint is cool examine the connection.

*c.* If the solder deposit is not smooth and shiny, reheat the joint and allow the solder to run again, as the joint was not sufficiently hot the first time. If the solder does not adhere, carefully clean the wire tip and the terminal, and connect and resolder when the joint is well heated. Clean off any surplus resin flux by using a hard bristle brush.

## Section II. CONTROLS

*Note.* This section describes, locates, illustrates, and furnishes the operator sufficient information pertaining to the various controls and instruments provided for the proper operation of the equipment.

### 13. Use of Switches

All switches when operated to a forward position are moved away from the operator. When they are operated to a rear position they are moved toward the operator.

### 14. Cord Circuit Switches (fig. 11)

*a.* LISTENING SWITCHES. The row of 15 one-position, locking, lever-type switches marked LIST, is located at the front of the switch shelf, each alined with its particular associated cord. Operation of a listening switch serves to connect the operator's telephone set to a particular cord circuit for talking or listening.

*b.* RINGING SWITCHES. The row of 15 two-position, nonlocking, lever-type ringing switches marked R ANS and R CALL are located at the rear of the switch shelf, each switch alined with its particular associated cord pair. When one of these switches is operated to its forward position, it rings a called line; when operated to its rear position it rings back on an answered line.

### 15. Secondary Cut-off Switch (Monitor)

This nonlocking, lever-type, one-position switch marked SEC CO is located at the left-hand side of the switch shelf and is held operated before a listening switch is used to permit the operator to monitor or listen without disturbing a conversation.

### 16. Generator Switch (fig. 11)

This one-position, lever-type, locking switch marked GEN SW is located at the left-hand side

of the shelf. When this switch is moved forward, it connects the magneto ringer to the ringing current leads. When in its normal position, contacts of this switch connect an outside ringing generator to the switchboard.

### 17. Fuse Alarm Switch

The fuse alarm switch marked FA is a one-position, lever-type, locking switch located at the left-hand side of the switch shelf. Its function is to silence the fuse alarm while a blown fuse is being replaced.

### 18. Night Alarm Switch

This one-position, lever-type, locking switch marked NA is located at the left-hand side of the switch shelf in line with the listening switches. When operated, this switch silences the night alarm bell.

### 19. Cord Test Jacks and Switch

The cord test circuit is provided to indicate proper operation of various cord circuit features. Separate test jacks are used to test for common battery or magneto operation. The cord test jacks and switch are located at the bottom of the front right-hand panel (fig. 2). The left-hand jack is used to test cords for common battery operation; the right-hand jack is used for magneto operation.

*a.* COMMON BATTERY OPERATION. Insertion of a cord plug into the common battery test jack should light the supervisory lamp for that cord. Operation of the test switch is equivalent to an-

swering a called telephone and the supervisory lamp should be extinguished.

b. **MAGNETO OPERATION.** Insert a cord plug into the magneto test jack. Operating the test switch will light the supervisory lamp for that cord. Closing the listening switch results in the light being extinguished.

## 20. Dial (fig. 11)

When a dial cord is inserted into a trunk line dial jack and the dial is operated, a trunk connection to a dial office is established. As soon as dialing is completed, the dial cord is withdrawn from the trunk dial jack and the circuit is completed to the called party.

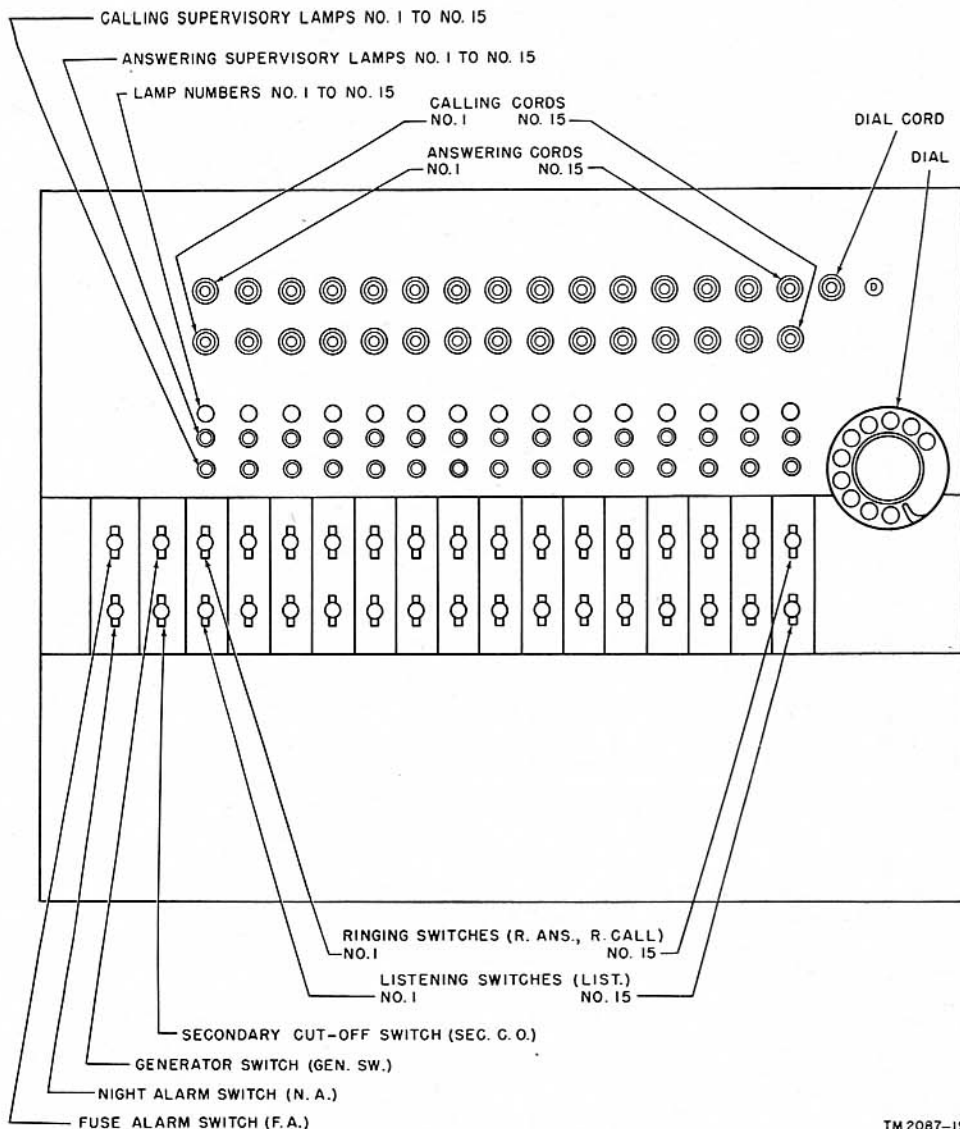

TM 2087-19

Figure 11. Switchboard SB-53( )/FTC (Kellogg type) switch shelf, top view, showing arrangement of cords, lamps, and switches.

## Section III. OPERATION UNDER USUAL CONDITIONS

### 21. General

a. **POWER AND PROTECTIVE EQUIPMENT.** Whether Switchboard SB-53( )/FTC is used as a branch exchange in a telephone central office or by itself

as a small main exchange, the necessary power and protective equipment, the efficiency of which will be checked by authorized maintenance personnel, will be provided. The operator will have to make only routine preoperational tests. These tests are



described in this section after a description of the use of cord circuits.

*b. USE OF CORD CIRCUITS.* Each cord circuit is used to establish a connection between two telephones. Operation of a listening switch associated with a cord pair connects the operator's telephone set for talking and listening.

*c. INCOMING CALLS.* To answer an incoming call, the operator inserts a rear or answering cord plug into the jack for the line over which the call is being made, and operates the associated listening switch.

*d. OUTGOING CALLS.* To make an outgoing call, the operator inserts a front or calling cord plug into the jack for the line of the telephone to be called and operates the associated ringing switch. When the called party answers, the circuit is completed.

*e. CALLING ANOTHER SWITCHBOARD OR EXCHANGE.* To call another switchboard or exchange, the operator inserts a calling cord plug into a trunk line jack and the dial cord plug into a trunk dial jack, and then operates the dial. This establishes a trunk connection. When dialing is completed, the operator withdraws the dial cord from the trunk dial jack and the circuit to the distant switchboard or exchange is complete. The operator at the distant switchboard or exchange answers the trunk connection and, if so instructed, rings a telephone associated with that exchange.

*f. TERMINATING A CALL.* The supervisory lamps, associated with the cords over which conversation has ceased, light when a call is terminated; this signals the operator that the cords establishing the connection may be disconnected and the board may be restored to normal.

## 22. Preoperational Tests

*a. BATTERY VOLTAGE.* Because authorized installation and maintenance personnel previously have checked the efficiency of the power source, the operator determines if there is battery voltage for satisfactory operation of the various circuits by testing for ringing voltage and checks the performance of the night alarm.

*b. RINGING CURRENT.* To test for ringing current, ring a local station which is known to be attended. If the station does not answer, use the manually operated magneto generator. If the station still does not answer, the operator should notify authorized maintenance personnel. *An operator should not attempt repairs for which other*

*personnel have been especially trained.* Such practice will usually result in multiplying trouble.

*c. NIGHT ALARM.* To test the night alarm, call a station which is known to be attended and request a recall. This test also serves to check for ringing current when signaling the called station. Prepare the circuit by setting the night alarm switch (figs. 2 and 11) to its ON position before the testing station calls back. The recall causes the night alarm bell to ring. When the test is completed, return the switch to normal.

## 23. Checking Line Lamps and Line Pilot Lamps

The line lamps can be checked during normal operation of the switchboard. If there is doubt as to the normal condition of a lamp, call a local station and request the called station to recall. This should light the line lamp. Whenever a line lamp lights, the line pilot lamp for that side of the board should also light; if the line pilot lamp does not light, notify the repair crew.

## 24. Checking Supervisory Lamps (fig. 11)

A calling cord supervisory lamp should light when its associated calling cord is inserted into a line jack; the lamp should remain lighted until the telephoned station answers. An answer cord supervisory lamp lights if an answer cord plug is in a jack and the originator of a call hangs up. On termination of a call, both lamps will remain lighted until the cords are removed from the line jacks.

## 25. Fuse Alarm Test

The fuse alarm is tested occasionally by placing a jumper between the battery bus-bar and the alarm bar. The jumper may be a piece of bare wire or a screw driver. If the alarm is working properly, the audible alarm will sound.

## 26. Adjustment of Operator's Telephone Set

See that the neck band attached to the chest plate is adjusted. The operator should be able to talk directly into the transmitter horn.

## 27. Methods for Completing Calls

The following tables of operating procedures summarize the connections possible and the methods for completing calls:

*a. LINE-TO-LINE CALLS.*

Indication	Operation	Result
Line lamp lights *-----	Insert answering cord plug into line jack for lighted lamp. Operate associated listening switch-----	Line lamp goes out. Connection established from operator to calling party.
Calling supervisory lamp goes out----- Either supervisory lamp flashes intermittently. Both supervisory lamps light-----	Obtain number from calling party. Insert associated calling cord plug into called number line jack. Ring called number using calling cord ring switch. ----- Operate listening switch and ask for instructions. Do not take down cords. Take down cords. It is not necessary to operate switches.	Calling supervisory lamp lights Called telephone rings. ----- Called party has answered. Either party on the line desired operator service. The call has been terminated.

*b. LINE-TO-TRUNK CALLS.*

Indication	Operation	Result
Line lamp lights *-----	Insert answering cord plug into line jack for lighted lamp. Operate associated listening switch-----	Line lamp goes out. Connection established from operator to calling party.
Supervisory lamp goes out----- One supervisory lamp flashes intermittently. Both supervisory lamps light-----	Obtain number from calling party. Insert associated calling cord plug into proper trunk jack. If manual trunk, give instructions to central office operator. If dial trunk, insert dial cord plug into trunk dial jack. Dial number and remove dial plug from jack, after dialing. After connection is established, move listening switch to normal position. ----- Operate listening switch and ask for instructions. Do not take down cords. Take down cord connections. It is not necessary to operate switches.	Calling supervisory lamp lights. Central office operator will complete the call. Dial equipment in central office will complete call. ----- Operator's circuit is disconnected and made available for other calls. Called party has answered. One of the parties on the line desired operator service. Call has been terminated.

\*On magneto lines the lamp will flicker only when the crank is turned.

### c. TRUNK-TO-LINE CALLS.

Indication	Operation	Result
Trunk lamp lights*	Insert answering cord plug into trunk jack for lighted lamp. Operate associated listening switch	Trunk lamp goes out. Connection established between operator and calling party.
Supervisory lamp goes out	Obtain number from calling party. Insert associated calling cord plug into proper line jack. Ring called party by operating calling cord ringing switch.	Calling cord supervisory lamp lights. Called telephone rings. Called party has answered.
One supervisory lamp flashes intermittently.	Operate listening switch and ask for instructions. Do not take down cords.	Either party desired operator service.
Both supervisory lamps light	Take down cord connections. It is not necessary to operate switches.	The call has been terminated.

\*On magneto lines the lamp will flicker only when the crank is turned.

## 28. Purpose of Equipment Performance Checklist

Operators use the equipment performance checklist to determine proper switchboard operation. These checks are to be made before, during, and after the switchboard is in service. The checklist lists the items that require attention if proper operation of the switchboard is to be obtained.

## 29. Use of Equipment Performance Checklist

The *action or condition* column indicates the condition that must exist before the check can be made. The *normal indication* column lists the visible or audible evidence that the operation is satisfactory. The *corrective measures* column indicates the steps which are to be taken by the operator, or problems to be referred to the repair crew for further attention.

## 30. Equipment Performance Checklist

Item No.	Item	Action or condition	Normal indication	Corrective measures
1	Trunk circuit.	Make connection.	Talk and listen.	If one position inoperative, use other and notify repair crew.
2	Ringing.	See below.	Station answers.	
3	Generator switch.	Call attended station by ringing with switch in both positions.	Station answers.	
4	Supervisory lamps.	Call attended station and request recall.	Calling supervisory lamp goes out when party answers. Answering supervisory lamp goes on when party hangs up after recall.	Replace lamps.
5	Line pilot.	Have one of the 50 lines on both panels recall.	Line pilot lights when line lamp in either panel lights.	Replace lamp.
6	Night alarm.	Have party recall with NA switch in either position.	Bell rings when alarm is on. Bell does not ring when alarm is off.	
7	Operator's set.	Connect to switchboard and make call.	Talk and listen.	
8	Dial and dial cord.	Connect to trunk.	Dial trunk operator, talk and listen.	
9	Cord circuit	Use cord test (par. 19).		
10	Cord switches.	Use cord test (par. 19).		

## Section IV. OPERATION UNDER UNUSUAL CONDITIONS

### 31. Magneto Ringing

If ringing current cannot be furnished by an outside ringing generator, use the hand-operated magneto generator in the switchboard. Set up the call circuit, operate the generator switch to magneto position, and turn the magneto crank while holding the ringing switch operated.

### 32. Operation Under Gas Conditions

*a.* When operating under gas conditions, it is necessary to resort to emergency measures to maintain telephone communication. The operator should be familiar with Microphone T-45 and Microphone T-30. Microphone T-45 is a lip microphone, and Microphone T-30 is a throat

microphone. Both are designed for use with gas masks.

*b.* These microphones cannot be adapted for use with the operator's telephone set issued with Switchboard SB-53 ( )/FTC, but the using organization may supply a type of operator's telephone set with which these microphones can be used. Chest Set H-18/FT is such a type. To prepare Chest Set H-18/FT for operation under gas conditions using Microphone T-45 or Microphone T-30, insert Plug PL-219 or Plug PL-219A of the microphone into the proper jack on the chest set.

*c.* If the using organization has these microphones on hand, they should be assembled and ready for instant use.

## CHAPTER 3

# MAINTENANCE INSTRUCTIONS

### Section I. SPECIAL ORGANIZATIONAL TOOLS AND EQUIPMENT

#### 33. Materials Required

Common materials required for organizational PM (preventive maintenance) procedures applying to Switchboard SB-53( )/FTC are listed below:

<i>Signal Corps stock No.</i>	<i>Materials</i>
6Z2056.....	Clean, dry cloth.
621590.....	Soft, dust brush.
6G1516.....	Polish, metal, paste, Federal specification No. P-P556, type III.
6Z7360.....	Orange stick. Solvent, dry-cleaning, (SD), Federal specification No. P-S-661a QM stock No. 51-S4385-1.

#### 34. Tools Required

Such tools as are needed for organizational maintenance of Switchboard SB-53( )/FTC are supplied with each switchboard in a canvas case. The case (fig. 12) contains the following tools:

No. 14.....	Socket wrench.
No. 68.....	Burnisher in sheath.
No. 13.....	Socket wrench.
No. 16.....	Socket wrench.
No. 67.....	Spring bender.
No. 12.....	Socket wrench.
No. 60.....	Spring bender.
No. 22.....	Screw driver.
No. 11.....	Socket wrench.
No. 21.....	Screw driver.
No. 25.....	Lamp extractor.
No. 39.....	Flat-nosed pliers.

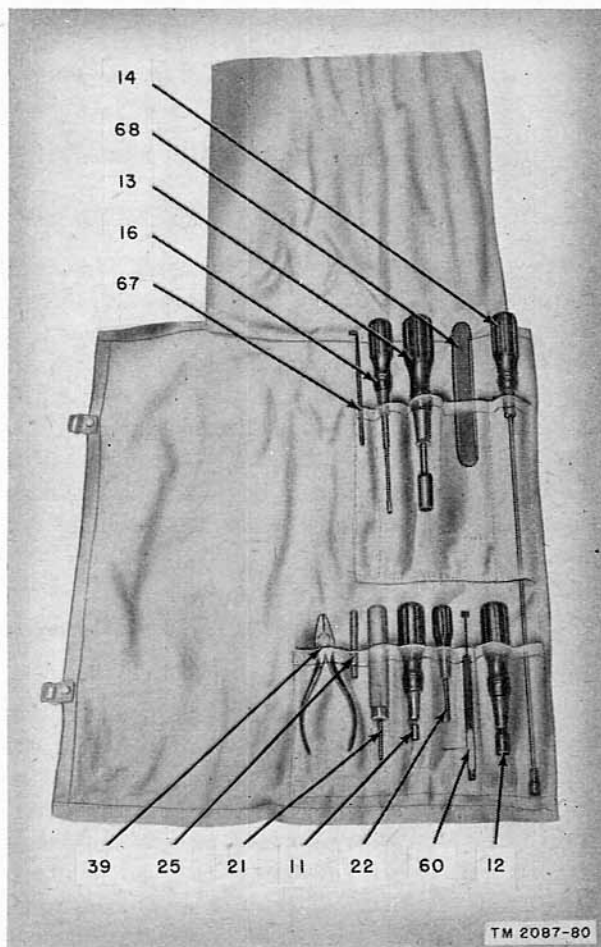

Figure 12. Tools supplied with Kellogg type switchboard.

### Section II. WEATHERPROOFING

#### 35. General

Switchboard SB-53( )/FTC is designed for indoor use at protected locations and is not weatherproofed. If, however, the switchboard may be as-

signed for use in locations where it should be weatherproofed, it will require special treatment and maintenance. Fungus growth, insects, dust, corrosion, salt spray, excessive moisture, and extreme temperatures are harmful to most materials.



## 36. Tropical Maintenance

A special moistureproofing and fungiproofing treatment has been devised which, if properly applied, provides a reasonable degree of protection. This treatment is fully explained in TB SIG 13, and TB SIG 72.

## 37. Winter Maintenance

Special precautions are necessary to prevent poor performance or total operational failure of equipment in extremely low temperatures. These precautions are fully explained in TB SIG 66.

## 38. Desert Maintenance

Special precautions are necessary to prevent equipment failure in areas subject to extremely high temperatures, low humidity, and excessive sand and dust. For proper maintenance of this equipment in desert climates, refer to TB SIG 75.

## 39. Lubrication

The effects of extreme cold and heat on materials and lubricants are explained in TB SIG 69. Observe all precautions outlined in TB SIG 69 and pay strict attention to all lubrication orders when operating equipment under conditions of extreme cold or heat.

### Section III. PREVENTIVE MAINTENANCE SERVICE

## 40. Meaning of Preventive Maintenance

PM is a systematic series of operations, performed at regular intervals, to eliminate interruptions in service and to maintain the equipment at top efficiency. PM techniques are used to prevent trouble, whereas trouble-shooting and repair procedures locate and correct existing defects. The importance of PM cannot be overemphasized in the continued functioning of a wire communications network when the network is needed at its maximum efficiency.

## 41. Description of Preventive Maintenance Techniques

After installation and initial adjustment, PM should be confined to the procedures given in the remainder of this section. Indiscriminate tampering with the equipment may disturb the adjustments of the switchboard apparatus and cause trouble. An installed switchboard is usually in continuous service; therefore, it is constantly checked for proper operation. Such equipment, if satisfactory, usually will remain so for long periods of time if not disturbed. For this reason, only authorized PM should be practiced, and the instructions given here are to be used as a guide for personnel assigned to such service.

**Caution:** Do not tighten screws, nuts, and bolts beyond the pressure for which they are designed. Overtightening will result in bent, broken, or otherwise damaged parts and stripped threads. Do not allow moisture, such as mop water, etc., to accumulate near the base of the switchboard or

around the cable entrance. Avoid placing partially filled beverage bottles on the switch shelf; when they are overturned they can be the cause of numerous troubles.

## 42. Preventive Maintenance Techniques

*a. GENERAL.* The following paragraphs outline PM services as applied to the various parts of the equipment.

### *b. SWITCHBOARD EXTERIOR.*

- (1) Inspect the exterior of the switchboard daily. Dust the equipment during inspection, using a dry cloth for the sides, top, and rear, and a soft brush for the front and shelf.
- (2) Examine the cord sockets for foreign matter to prevent fraying or binding and to insure proper seating of the plugs.
- (3) Check the front panel and switch shelf for loose mounting screws and tighten where needed. Screw loose switch lever handles tightly in place with the fingers. *Do not overtighten.*
- (4) Clean the jack sleeves with carbon tetrachloride once a week. Wrap a piece of lint-free cloth around an orange stick and dampen the cloth with the solution. Rotate the cloth in the jack sleeve, being careful not to contact the jack springs. Wipe the sleeve with a dry cloth.
- (5) Inspect the dial daily for free action of the finger wheel, a bent finger stop, or a defaced number plate. Clean a soiled number plate by application of a cloth

moistened in carbon tetrachloride; if badly scratched or if the numbers are obliterated, replace the plate.

*c. SWITCHBOARD INTERIOR.* Remove the rear cover and inspect the interior once a week for evidence of irregularity. In the event that adjustments must be made, do it with the least possible disturbance to the adjacent equipment and to the equipment involved. Remove dust with a vacuum cleaner when possible. If a vacuum cleaner will not reach or is not available, use a soft brush.

*d. CORDS AND PLUGS.*

(1) *Plugs.* Clean the plugs monthly with a rouge polish until the contact surfaces are bright and clean. Be sure to remove all traces of rouge after cleaning. Inspect for cracked or chipped shells or insulators; if damaged, replace.

(2) *Cords.* Lift the cords as far as possible and check for free travel and free running cord weights. Clean cord jackets when they are dirty with a dry cloth or brush. If badly frayed, replace.

*e. SWITCHES.* Check daily for free operation and return. Examine the lever and push-button switch handles; if they are broken or chipped badly, replace them.

*f. LAMPS.* While the board is in operation, check for any burned out lamps or bent, cracked, or missing lamp caps. Replace any faulty part immediately.

*g. FUSES.* Inspect the fuses monthly for dirt, dust, and corrosion. Examine carefully for fuses that may have blown but do not make contact with the alarm bar.

*h. NIGHT ALARM.* Observe daily whether the night alarm operates properly. Throw the night alarm switch to ON during a period of heavy traffic. If the alarm is in operation, the night alarm bell should ring with each call.

*i. OPERATOR'S TELEPHONE SET.* Inspect the

head set for dust, dirt, loose connections, and a damaged cord or plug. Replace an excessively frayed cord. Clean with a dry, soft cloth.

### 43. Preventive Maintenance Checklist

A switchboard in service is under continuous observation and test for proper operation, through actual use. The PM inspections required in addition to such observation are summarized in the following checklist.

Item	Description	Daily	Weekly	Monthly
1	Switchboard exterior	X		
2	Cord sockets	X		
3	Jack sleeves		X	
4	Dial	X		
5	Switchboard interior		X	
6	Plugs			X
7	Cords			X
8	Switches	X		
9	Lamps	X		
10	Fuses	X		
11	Fuse alarm		X	
12	Night alarm	X		
13	Operator's set		X	

### 44. Trouble Shooting

A thorough knowledge of the operation of each circuit of the switchboard is of fundamental importance in analyzing trouble. The trouble shooter must be able to prove quickly whether trouble exists in a particular circuit. The appearance of a failure may indicate the exact location of the faulty adjustment or damage; if not, it will be necessary to determine exactly those functions which are at fault. To enable authorized repair personnel to more readily locate trouble, chapter 4 of part two of this technical manual contains trouble location information. Refer also to the equipment performance checklist (par. 30).

## CHAPTER 4

# TECHNICAL SERVICES—FIELD AND DEPOT MAINTENANCE INSTRUCTIONS

### Section I. GENERAL

#### 45. Scope and Application

*a.* This chapter covers instructions for the complete repair and rebuilding of Switchboard SB-53( )/FTC at mobile or fixed shops (field or depot maintenance). The extent of repair which any field or depot maintenance unit undertakes is limited only by the tools and test apparatus available at the location and by the degree of skill of assigned personnel.

*b.* Since Switchboard SB-53( )/FTC (Kellogg type) and Switchboard SB-53( )/FTC (Stromberg-Carlson universal type 106) differ in circuit features, yet perform identical functions, it is necessary to discuss the circuit theory of the switchboards separately. The circuit features of the Kellogg type switchboard are explained in paragraphs 47 through 62. Circuit features of the Stromberg-Carlson universal type 106 switchboard are covered in part three of this manual.

#### 46. Repair References

*a.* Refer to the following technical manuals before performing tests or making repairs on Switchboard SB-53( )/FTC:

TM 11-4301--- Tactical Switchboards and Long Lines Equipment—

Repair Instructions, General Requirements.

TM 11-4302--- Tactical Switchboards and Long Lines Equipment—Repair Instructions, Apparatus Requirements.

*b.* Before using the test sets referred to in section 3 of this chapter, refer to the following technical manuals:

TM 11-2019--- Test Set I-49.

TM 11-2036--- Test Set I-181.

TM 11-2039--- Preliminary Instructions 19C (SPL) Oscillator Per D-166636 (Moisture-Resistant). This technical manual covers Audio Oscillator TS-379/U.

TM 11-2042--- Preliminary Instructions Volt-OHM-Milliammeter Per D-166852 (Moisture-Resistant).

TM 11-2045--- Decibel Meter TS-399/U, 13A (SPL), Transmission Measuring Set Per D-165655 (Moisture-Resistant).

### Section II. THEORY OF OPERATION

#### 47. Universal Line Circuits

*a.* CONNECTED FOR COMMON BATTERY OPERATION (fig. 13). When a telephone receiver is lifted, the hookswitch closes the loop circuit and causes the line relay to operate. Springs 1 and 2 of the line relay make contact and complete the circuit to light the line lamp. This signals the operator to answer by inserting the plug of the answering cord into the line jack. This opens the inside jack cut-off spring contracts to disconnect ground and battery from the line. The line relay then releases;

springs 1 and 2 break the circuit and the line lamp is extinguished.

*b.* CONNECTED FOR MAGNETO (fig. 14). Cranking the magneto generator of a telephone switchboard causes ringing current to be transmitted over the line through the line relay and line lamp in series. This operates the line relay and completes a locking circuit from ground on spring 6, through spring 7, the line jack ring spring, the cut-off spring, the line relay winding, and springs 2 and 1 to battery. Battery connected through springs 1 and 2 and the line lamp to ground causes the line



lamp to light and signals the operator. Circuit operation is then the same as described for common battery operation in *a* above.

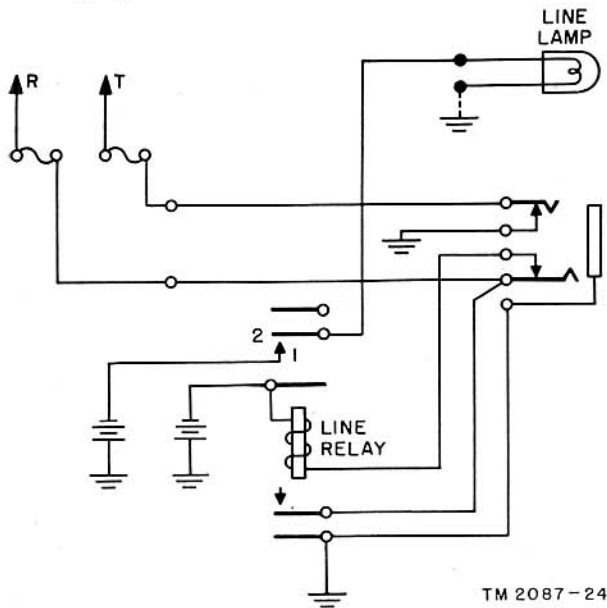

TM 2087-24

Figure 13. Universal line circuit connected for common battery operation, schematic.

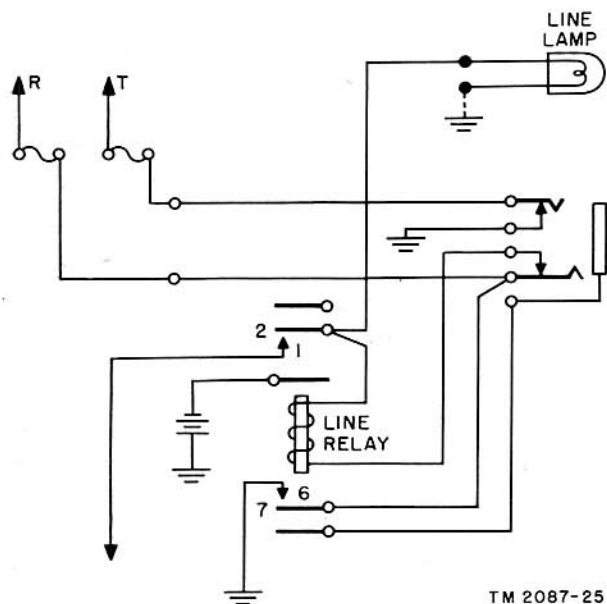

TM 2087-25

Figure 14. Universal line circuit connected for magneto operation, schematic.

#### 48. Universal Trunk Circuits (fig. 15)

##### *a.* OUTGOING CALLS.

- (1) *To common battery exchanges.* Insertion of a cord plug in the trunk line jack causes a make contact of the line jack to complete the circuit to ground through a

break contact of relay 1 for the operation of relay 3. Make contacts 1 and 2 of relay 3 close the line loop through the repeating coil winding.

- (2) *To magneto exchange.* The trunk circuit to a magneto exchange functions as described for the common battery exchange except that the local operator must ring to signal the operator at a distant exchange.
- (3) *To dial exchange.* To call a dial exchange, a calling cord plug is inserted in the trunk line jack and the dial cord plug in the trunk dial jack. Ground on the ring conductor of the dial cord connected through the ring spring of the dial jack causes relay 4 to operate. Break contacts 1 and 2 of relay 4 disconnect the trunk equipment and leave the dial directly connected to the trunk. Operation of the dial opens the line and causes pulses to the called office through the dial jack. After dialing, the dial cord plug is removed.

*b.* INCOMING CALLS. On all incoming calls ringing current operates the a-c relay 1. The make contact of relay 1 completes the circuit to ground for the operation of relay 2 which holds to ground through make contact 2 and through break contact 3 of relay 3. Relay 1 releases after ringing current is removed, and ground at its break contact completes the circuit to light the line lamp through make contact 1 of operated relay 2. The line lamp signals the operator and the operator answers by inserting an answering cord plug in the line jack. This closes the line jack contact to complete the circuit for the operation of relay 3. At break contact 3 of relay 3, the circuit to ground is opened for relay 2 which releases, and contact 1 of relay 2 disconnects the line lamp which is extinguished. Relay 3 at make contacts 1 and 2 connects the talking conductors to the repeating coil to establish the talking circuit.

#### 49. Universal Cord Circuit (fig. 16)

The universal cord circuit provides means for supervising common battery connections, for making busy tests, for connecting the operator's telephone set to the cord circuit, for ringing on either the tip or ring of the calling cord, for establishing talking connections, and for providing a nonlocking lamp ring-off signal on magneto line connections. The cord circuits for establish-

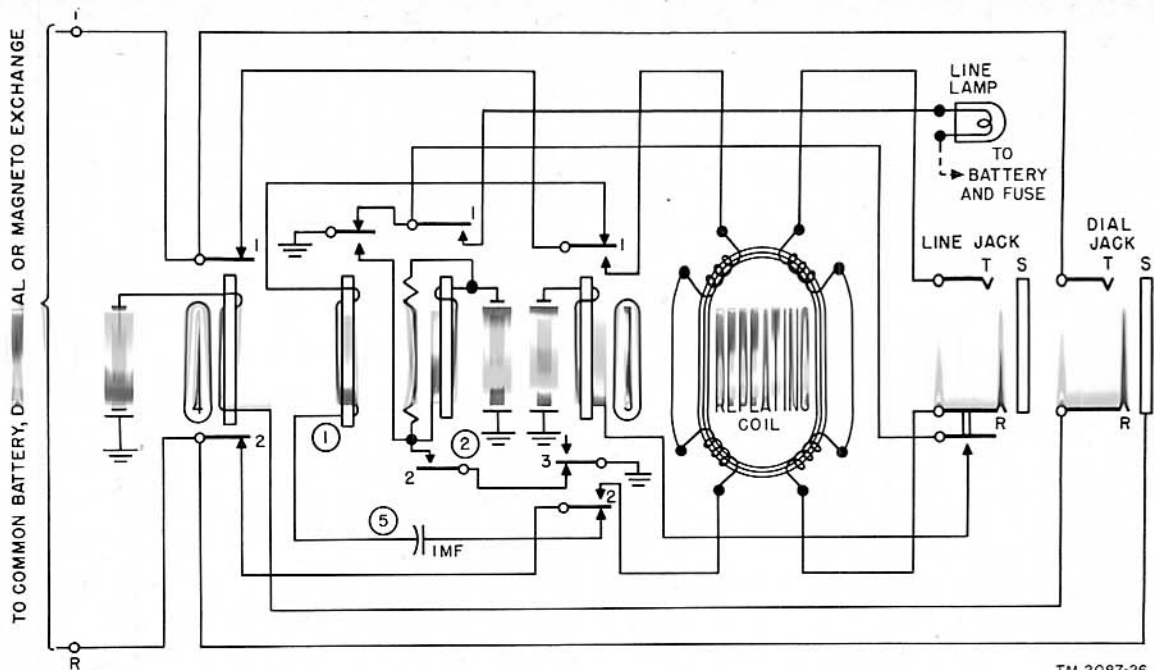

TM 2087-26

Figure 15. Universal trunk circuit, schematic.

ing a connection to a called telephone are the same as for establishing a connection to a trunk. They are designed for use with both common battery and magneto telephones associated with the switchboard and dial telephones by way of trunks.

a. COMMON BATTERY TO COMMON BATTERY CONNECTIONS.

- (1) The answering cord plug is inserted into the line jack of the calling telephone or trunk and the listening switch is moved to the operated position. Ground on the sleeve of the jack through the sleeve connection of the cord completes the circuit to battery through the 3-4 winding of relay 1. In operating, relay 1 closes its make contacts 1 and 2, which in turn complete the circuit for operation of relay 2, ground being furnished through the 4-3 winding in series with the line loop and winding 1-2 of relay 1.
- (2) At make contact 1 of relay 1, ground from winding 4-3 of relay 2 is connected through repeating coil winding 1-2, a ring-back switch contact, and tip of plug to the tip wire of the calling line. At make contact 2 of relay 1, talking battery from winding 1-2 of relay 1 is connected through repeating coil winding 7-8, a ring-back switch contact, and ring contact of the plug to the ring wire of the calling line. At make contact 3 of operated relay 1, ground is connected to the answering cord supervisory lamp cir-

cuit, but the circuit is held open at the break contact of operated relay 2 so that the lamp does not light. After moving the listening switch to the operated position, the operator receives the called number and then inserts the calling cord plug into the line jack of the called telephone which causes the operation of relay 3 and the connection of talking battery to the called line in the same manner as described above for relay 1.

- (3) Since relay 4 is not operated because of the called line loop being open, ground at make contact 3 of operated relay 3 completes the circuit to light the calling cord supervisory lamp. The operator then operates the ring switch. When the called telephone is answered the circuit is completed. The operation of relay 4, which at its break contact opens the circuit of the calling cord supervisory lamp, causes the lamp to be extinguished. The operator then returns the listening switch to normal.
- (4) To recall an operator, a local telephone receiver hookswitch must be operated and released to provide a flashing call lamp at the switchboard. When an operator monitors, the local receiver must be off the hookswitch in order that the operator's challenge may be heard at the station. Circuit operation for either recalling an operator or terminating a call is alike.

When the hookswitch is in operated position, the line loop circuit is opened through winding 3-4 of relay 2 for the calling telephone and relay 4 for the called telephone. When released, these relays close a break contact which completes the circuit through make contact 3 of relay 1 for the calling telephone and through make contact 3 of relay 3 for the called telephone to light the cord supervisory lamp which signals the operator that additional service is required or that the call is terminated. When a call is terminated, the cord plugs are withdrawn from the line jacks and the relays restore to normal.

*b.* MAGNETO TO MAGNETO CONNECTIONS.

- (1) The answering cord plug is inserted into the line jack of the calling telephone or trunk and the listening switch is moved to the operated position. As the sleeve of the line jack of a magneto telephone is not grounded, relay 1 does not operate. After receiving the called number, the operator inserts the calling cord plug into the line jack of the called telephone. Relay 3 is not grounded and therefore does not operate. The ringing switch for the calling cord is then operated to ring the bell of the called telephone. When the ring switch is operated, the tip and ring break contacts on the switch from the cord circuit are broken, thereby preventing ringing current going back through the cord circuit into the calling party's receiver. Also, the make contacts of the ringing switch are made, putting ringing current over the line to operate the bell at the called party's telephone. When the called telephone has been answered, the operator returns the listening switch to normal for supervision.
- (2) Supervision for the operator and ringing current on the line is provided by operation of the hand generator. Ringing current on the ring side of the line goes to the ring of the plug, through a contact of the ring-back switch RB, to the 8-7 winding of the repeating coil to break contact 2 of relay 1, to the 2-1 winding of the repeating coil, and a break spring of the ring-back switch to the tip

side of the line. Ringing current will operate relay 2 over this circuit when a make contact of relay 2 closes. Battery is supplied from the ANS PIL CKT through the answer lamp, through a make contact of relay 2, a break contact of the LIST switch, break contact 1 of relay 1, and the 3-4 winding of relay 2 to ground. This lights the supervisory lamp.

- (3) To recall the operator and to terminate a call, the telephone magneto is cranked to generate 20-cycle ringing current which passes through winding 1-2 of relay 2 for the calling telephone and relay 4 for the called telephone. The ringing current causes only initial operation of these relays which are then held operated by a locking circuit through their respective windings 3-4 and the associated cord supervisory lamp. This circuit is then completed by the closing of the make contacts of relays 2 and 4.
- (4) When these relays operate and complete the locking circuit, the associated supervisory lamp lights to signal the operator that additional service is required or that the call has been terminated. The locking circuit for relay 2 is energized from the supervisory pilot circuit through the answering cord supervisory pilot lamp, the make contact of relay 2, a spring contact of the listening switch, break contact 1 of relay 1, and the 3-4 winding of relay 2 to ground. The locking circuit for relay 4 is energized from battery through the calling cord supervisory lamp, the make contact of relay 4, a spring contact of the listening switch, break contact 1 of relay 3, and the 3-4 winding of relay 4 to ground.
- (5) A supervisory lamp remains lighted until the locking circuit is opened by the operation of the listening switch when the operator determines whether another call is being originated or whether the call is terminated. If the call is terminated, the operator withdraws the cord plugs from the line jacks.

*c.* COMMON BATTERY TO MAGNETO CONNECTIONS.

Answering the call is described under common battery to common battery connections (*a* above).

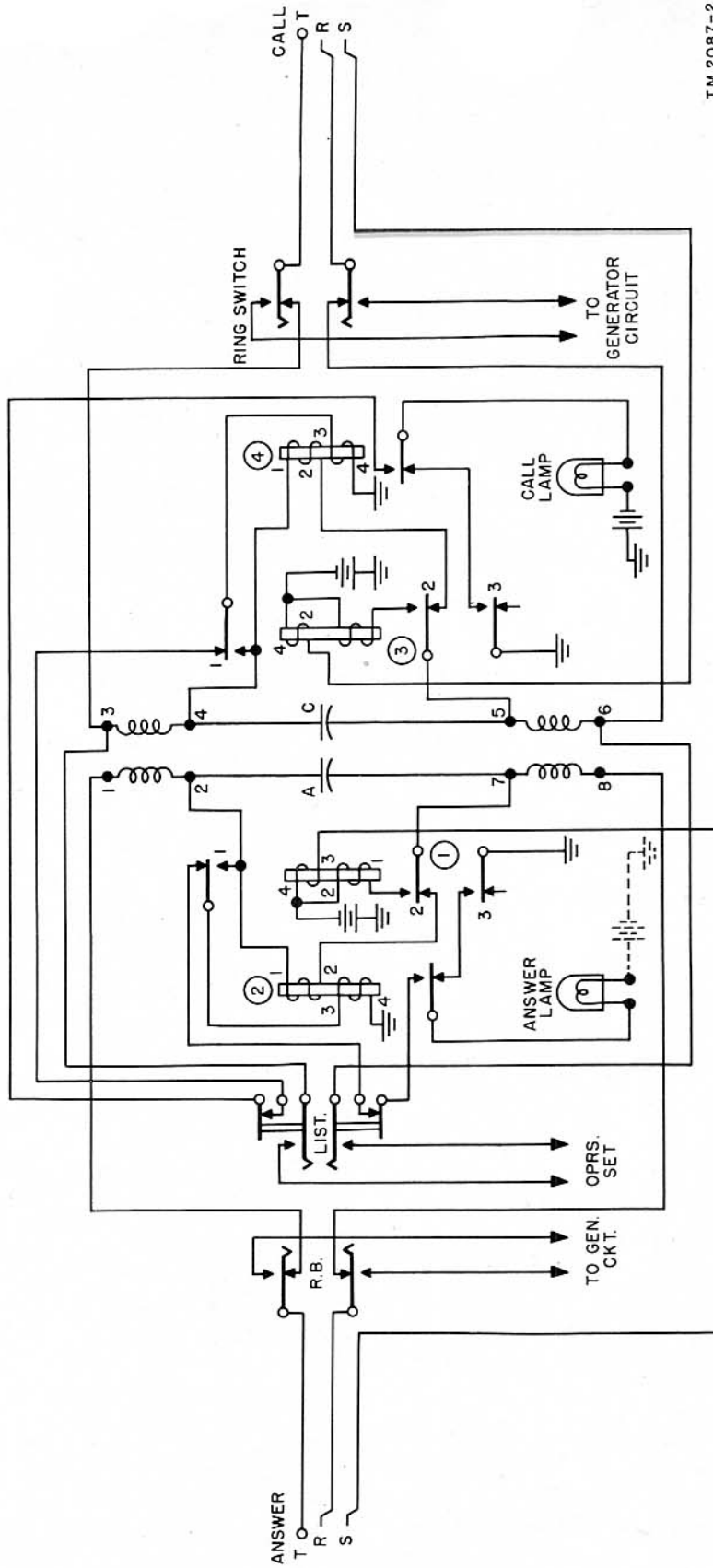

TM 2087-27

Figure 16. Universal cord circuit, schematic.

Establishing the connection to the called telephone is described under magneto to magneto connections (*b* above).

*d.* MAGNETO TO COMMON BATTERY CONNECTIONS. Answering the call is described under magneto to magneto connections (*b* above). Establishing the connection to the called telephone is described under common battery to common battery connections (*a* above).

### 50. Operator's Telephone Circuit (fig. 17)

The operator's telephone circuit in conjunction with the operator's telephone set is used to talk on a connection established through any cord circuit. The operator's headset is connected to the circuit by a plug inserted into the jack on the front of the switch shelf. The operator's telephone circuit is

a capacitor is bridged across the line, as are also auxiliary monitor terminals.

*b.* The operator's talking circuit is connected to a particular cord circuit by operating the listening switch of that cord circuit. To monitor or listen without disturbing a conversation, the secondary cut-off switch (fig. 17) is operated before the listening switch of a cord circuit is used. Operating the secondary cut-off switch connects ground to complete the circuit for the operation of relay 1. The secondary of the induction coil is disconnected from the line by the opening of break contacts 1 and 4 of relay 1. By closing contacts 1 and 4, the primary windings of a repeating coil are connected to the line. By the opening of break contacts 3 and 5, the receiver is disconnected from the induction coil secondary, and by the closing of

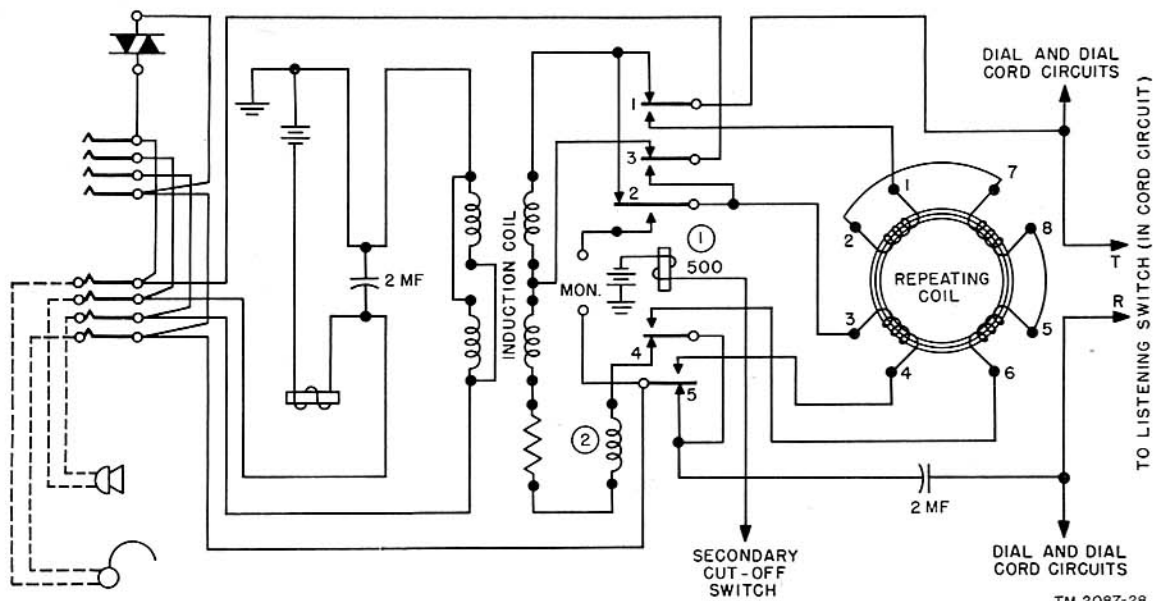

Figure 17. Operator's telephone circuit, schematic.

connected for antiside tone to reduce the noises in the operator's receiver.

*a.* The operator's telephone circuit of the Kellogg switchboard has a dial and dial cord associated with it. By plugging the operator's telephone set into the operator's jack the transmitter circuit is completed with battery, a retardation coil, the transmitter, and an induction coil primary in series. The receiver circuit is completed by the receiver being bridged across part of the induction coil secondary and resistors. The induction coil secondary in series with resistors and

make contacts 3 and 5, the receiver is connected to the repeating coil secondary. The monitor terminals are disconnected from the induction coil secondary by the opening of break contacts 2 and 5, and connected to the repeating coil secondary by closing make contacts 2 and 5.

### 51. Dial and Dial Cord Circuit (fig. 18)

The dial cord plug must be inserted into the dial jack of a trunk to establish a trunk connection to a dial office. The dial cord plug is removed from the dial jack as soon as dialing is completed. The



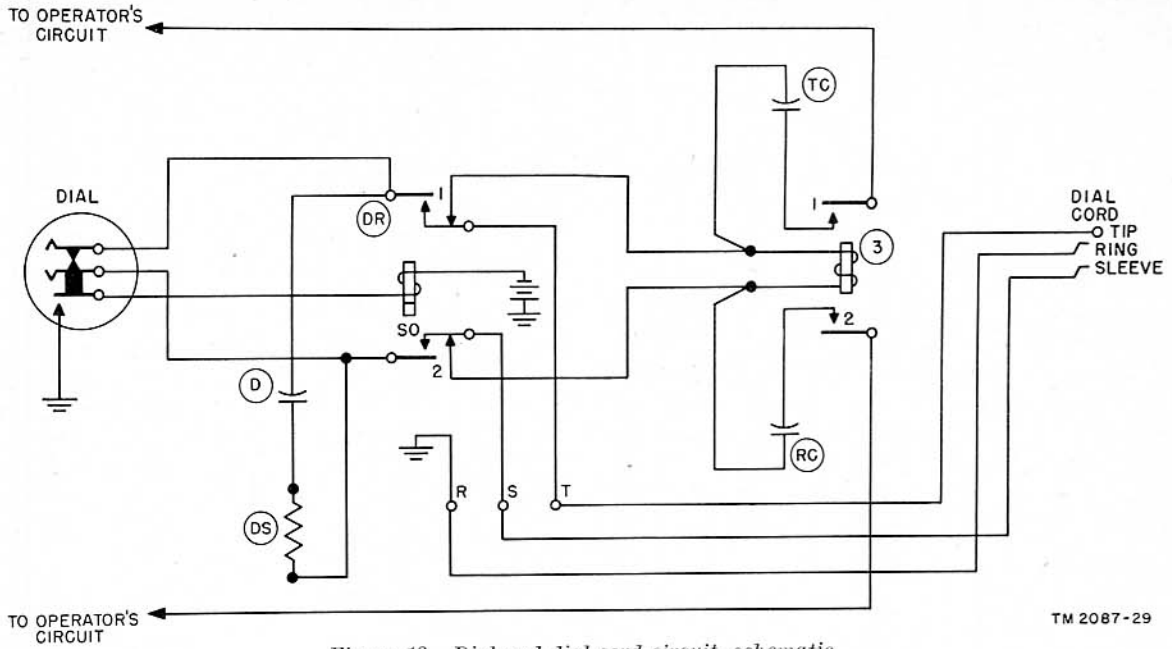

Figure 18. Dial and dial cord circuit, schematic.

TM 2087-29

operator's circuit and cord circuit then function the same as for calls to nondial offices.

a. The dial circuit is connected to the operator's circuit which permits the operator to talk to the dial office while the dial cord plug is in the dial jack. When the dial cord plug is inserted into a trunk dial jack, ground on the ring conductor completes the circuit for the operation of a trunk relay which disconnects the trunk equipment and leaves the trunk connected directly to the dial cord circuit.

b. Moving the dial off normal in dialing closes a dial make contact which completes the circuit for slow-release relay DR. This operates and remains operated during the train of dial pulses. During operation relay DR make contacts 1 and 2 connect the dial directly to the trunk line to transmit the pulses to the dial office equipment. Break contacts 1 and 2 of relay DR disconnect relay 3 so that only the dial remains connected. Capacitor D and resistor DS are connected across the dial contacts to reduce arcing. Relay 3 acts as a holding coil for the dial office equipment in conjunction with which it operates, and connects the operator's telephone circuit at contacts 1 and 2 of relay 3 for talking and listening. The battery from the dial office, which operates relay 3, is blocked from the operator's circuit by capacitors TC and RC.

## 52. Generator Circuit (fig. 19)

The generator circuit is used for furnishing the ringing current to the cord circuit ringing switches from either a power-driven generator or a hand-cranked magneto generator. The generator lever switch is of the locking type. A resistance lamp in the nongrounded power generator lead limits the ringing current and prevents damage to the generator if the ringing leads become short circuited. In the normal switch position of the

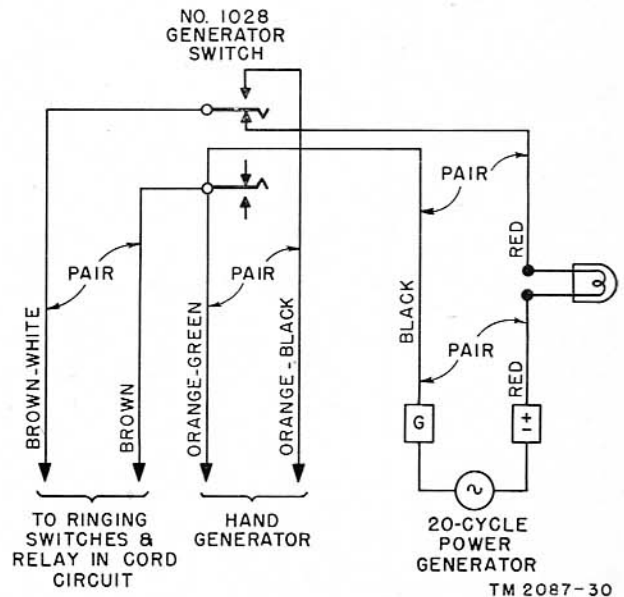

Figure 19. Generator circuit, schematic.

TM 2087-30

generator switch, ringing current is supplied from a power generator and in the operated position from a magneto hand generator.

### 53. Cord Test Circuit (fig. 20)

The cord test circuit is provided to test the various features associated with a cord circuit. The cords may be tested for operation with common battery and magneto telephone lines. The resistance values used are the limiting values of lines for which the cord circuit will function satisfactorily. The test circuit has a jack for testing cord operation with common battery lines and a jack for testing cord operation with magneto lines. A test switch is common to both jacks and its operation tests the cord for common battery or magneto operation depending in which jack the plug is inserted.

#### a. COMMON BATTERY CORD TEST CIRCUIT.

- (1) Inserting a cord plug into the common battery test jack bridges a 10,000-ohm resistor **R** across the tip and ring cord conductors. This represents the minimum insulation resistance of the line for which the cord circuit can function. Operating the test switch bridges an 800-ohm resistor **T** across the 10,000-ohm resistor **R**. The combined resistance represents the maximum resistance of a line loop includ-

ing the telephone. Satisfactory operation of the cord is indicated by its supervisory lamp lighting when the cord plug is inserted into the test jack. Ground on the sleeve of the test jack completes the circuit for the operation of cord circuit relay 1 or 3 which at a make contact in turn completes the circuit to light the corresponding supervisory lamp.

- (2) Operating the test switch is equivalent to answering the called telephone. It reduces the test circuit resistance to approximately 740 ohms, so that cord circuit relay 2 or 4 operates and a break contact opens the circuit to extinguish the supervisory lamp. Cord test circuit terminals are provided to which a test bell may be connected. A satisfactory ringing condition of the cord is indicated if a test bell rings when the ringing switch associated with the cord is operated and the test switch is in the normal position.

b. MAGNETO CORD TEST CIRCUIT. Inserting a cord into the magneto jack establishes a ringing circuit to the cord circuit which is completed at a make contact of the test switch when it is operated. Test switch operation represents ringing off at a magneto telephone which causes the cord circuit supervisory lamp to light as described under uni-

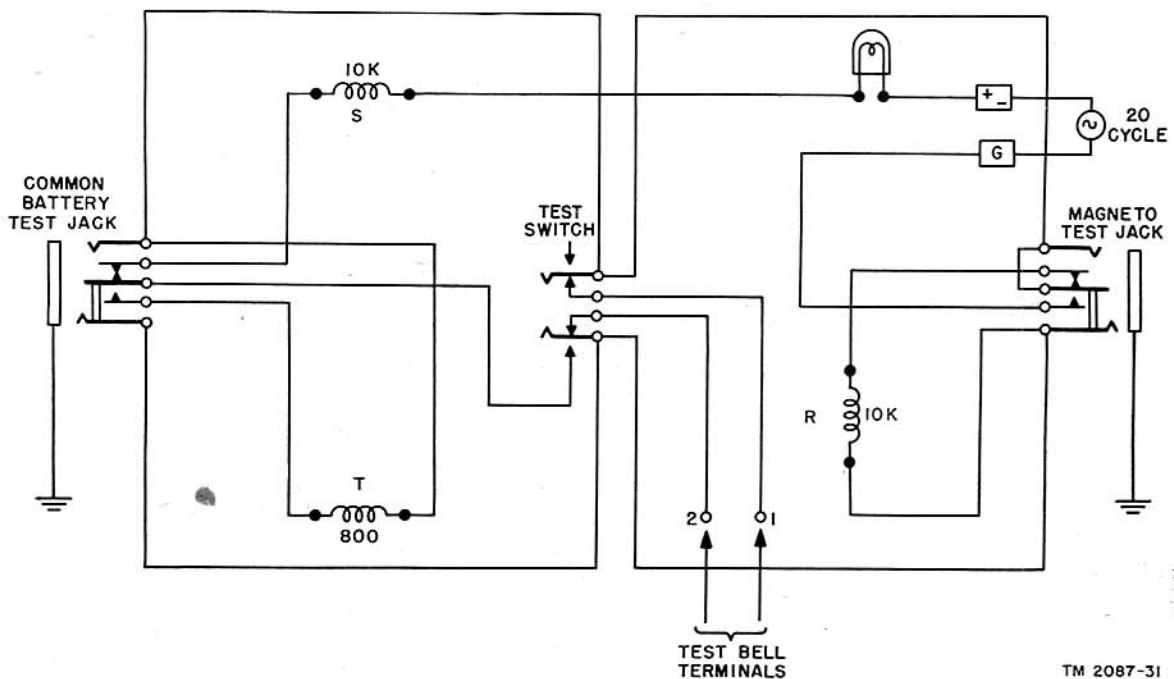

Figure 20. Cord test circuit, schematic.

TM 2087-31

versal cord circuit, magneto to magneto connections (par. 49). The cord circuit is further tested by operating the listening switch which opens the supervisory lamp circuit and extinguishes the lamp. A satisfactory ringing condition of the cord is indicated if the test bell rings when the cord ringing switch is operated and the test switch is in the normal position.

#### 54. Line Pilot Circuit (fig. 21)

*a.* There are two line pilot lamps on the face of the switchboard, one under each panel containing the line lamps with which a line pilot lamp is associated. A line pilot lamp lights when any of its associated line lamps light. It is a prominent lamp to quickly call the operator's attention to a lighted line lamp.

*b.* A separately fused circuit is used to supply current from battery bar A to the line lamps in the left panel while another circuit supplies the right panel. Each of these circuits passes through its own line pilot relay, one going to the left panel line lamp battery bar and the other to the right. Separately fused circuits from the left panel line lamp battery bar supply battery to groups of line lamps in the left panel. Groups of lamps in the right panel are similarly supplied with battery from the right panel line lamp battery bar. Current to light any line lamp in the left panel must pass through the left panel pilot relay causing it to operate.

*c.* The pilot relay for the right panel is operated similarly. A make contact which is closed by a line pilot relay completes the circuit to light its associated line pilot lamp. When the operator answers, by inserting a cord circuit plug into a line jack, the line relay circuit is opened at the line jack spring contacts. This causes the line re-

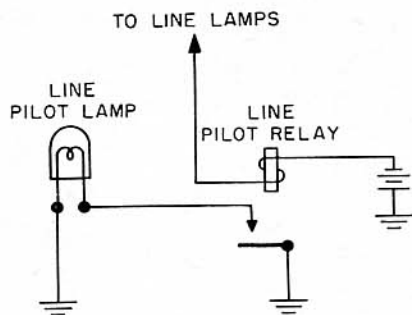

TM 2087-32

Figure 21. Line pilot circuit, schematic.

lay to release a contact and open the circuit of the line lamp and the line pilot relay. If there are no other unanswered calls, the line pilot relay releases a contact, opens the circuit, and extinguishes the line pilot lamp.

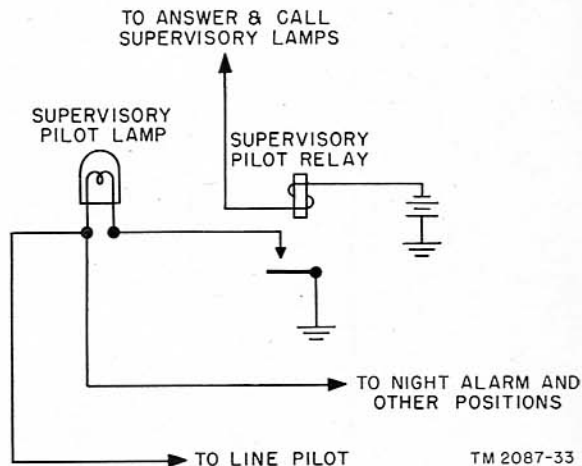

Figure 22. Supervisory pilot circuit, schematic.

#### 55. Supervisory Pilot Circuit (fig. 22)

*a.* A prominent supervisory pilot lamp is located on the face of the switchboard to indicate to the operator when an answering cord supervisory lamp is lighted. Each answering cord supervisory lamp circuit is completed through the supervisory pilot relay which operates whenever a cord supervisory lamp lights. A make contact of the supervisory pilot relay closes to complete the circuit through the night alarm relay and light the supervisory pilot lamp. The lamp is extinguished and the supervisory pilot relay is released when the supervisory lamp circuit is opened by operation of the listening switch in the operator's telephone circuit.

*b.* Battery is connected from battery bar D to the night alarm relay in a separately fused circuit used to light the supervisory pilot lamp whenever an answer cord supervisory lamp lights, and the supervisory pilot relay operates. The circuit to light the pilot lamp is from battery through the night alarm relay, pilot lamp, and a make contact of the supervisory pilot relay to ground. The pilot lamp lights when the pilot relay operates.

#### 56. Night Alarm Circuit (fig. 23)

*a.* The circuits for both the line pilot lamps and supervisory pilot lamp are completed



through a night alarm relay which operates whenever either of these pilot lamps lights. A make contact of the night alarm relay completes a circuit through the contacts of the night alarm switch to ring the night alarm bell which audibly notifies the operator that a pilot lamp has been lighted. The alarm is needed only when calls are infrequent and the continued attention of the operator is not required. The night alarm may be disconnected by the night alarm switch.

b. Battery connected to the night alarm relay supplies current to light the line pilot lamps and the supervisory pilot lamp. When one of these pilot lamps lights, current through the night alarm relay causes the relay to operate and complete the night alarm circuit through the night alarm switch contacts. The switch must be in the operated position for the alarm bell to ring. If the operator does not need the alarm, restoring the switch to normal disconnects the circuit.

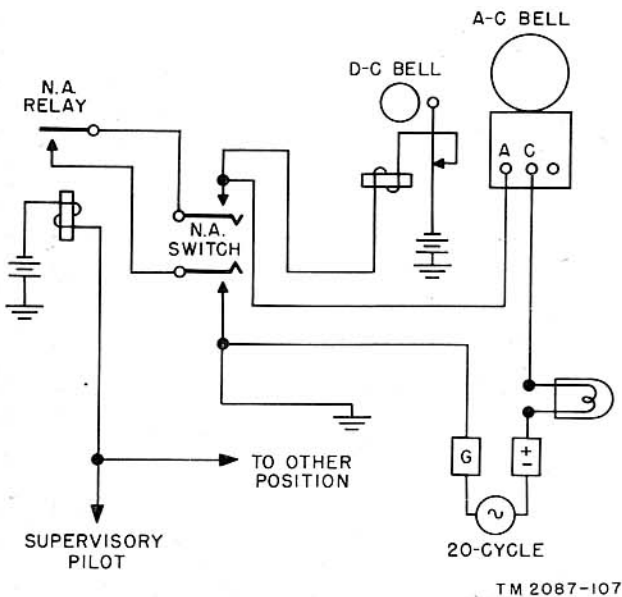
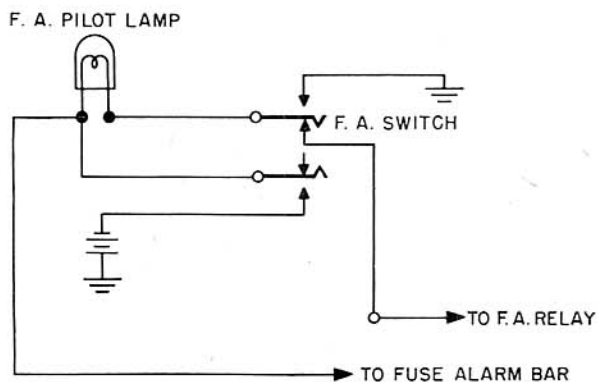

Figure 23. Night alarm circuit, schematic.

### 57. Fuse Alarm Pilot Circuit (fig. 24)

A prominent fuse pilot lamp is located on the face of the Kellogg type switchboard to notify the operator of a blown fuse. When a fuse blows, a spring contact on the fuse is released and connects battery to an alarm bar (fig. 24) to complete a circuit through the fuse alarm pilot lamp, a contact of the fuse alarm switch, and the fuse alarm

relay to ground, to light the lamp. Removing the blown fuse opens the circuit and extinguishes the lamp.



TM 2087-34

Figure 24. Fuse pilot circuit, schematic.

### 58. Fuse Alarm Circuit (fig. 25)

The circuit for the fuse alarm buzzer is completed at a make contact of the fuse alarm relay. This operates whenever the fuse pilot lamp lights. The fuse lamp and alarm relay are connected in series through a contact of the alarm switch. When desired, the audible alarm may be silenced by operating the switch which disconnects the relay to break the alarm buzzer circuit. However, at make contacts of the operated fuse alarm switch, battery and ground are connected to the fuse pilot lamp to complete a new circuit and keep

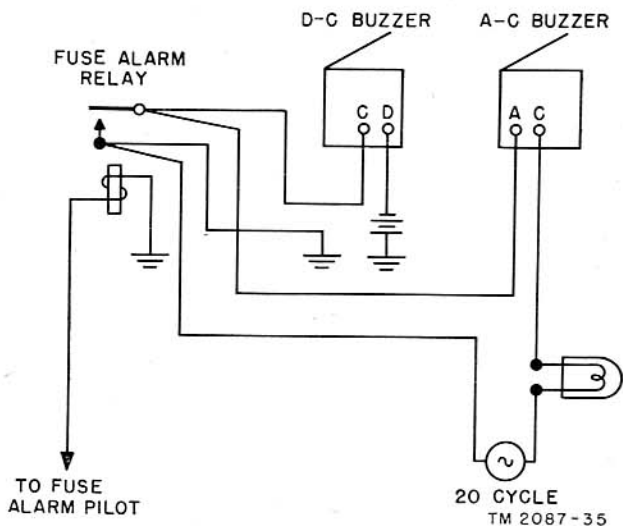

TM 2087-35

Figure 25. Fuse alarm circuit, schematic.

it lighted as a reminder to replace the blown fuse. After replacing a blown fuse, the alarm switch must be returned to normal to reset the circuit for the fuse pilot lamp and fuse alarm buzzer to function if another fuse blows.

### 59. Ground Circuit (fig. 26)

A ground circuit connection is provided to the relay frame or gate, jack frame, and switch frame. The circuit is shown in figure 26.

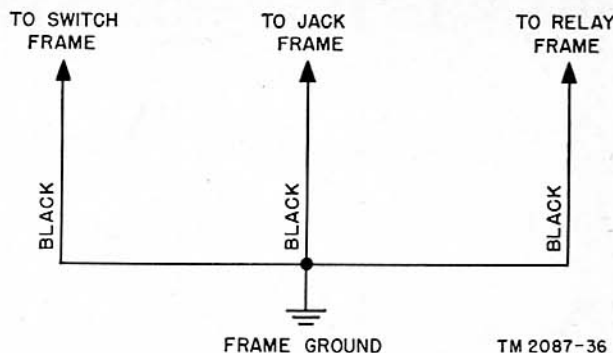

Figure 26. Ground circuit, schematic.

## Section III. PREREPAIR REQUIREMENTS

### 60. Test and Repair Equipment

To repair and maintain Switchboard SB-53( ) / FTC, proper tools, test equipment, and materials are required. A tool kit is furnished with each switchboard for ordinary repairs. Refer to paragraph 34 and figure 12 for the list of tools included with the Kellogg universal switchboard.

### 61. Materials

Depending on the condition of a switchboard, various materials are required for its reconditioning and repair. The following may be required:

Signal Corps stock No.	Material and description
621590	Brush, soft bristle, dust.
6G1841	Carbon tetrachloride, such as WECO 6815.
8A805	Cheesecloth, lint-free, such as WECO 6350.
6Z2056	Cloth, such as WECO D-98063 cloth.
6N6890	Cotton sleeving, 3/2" wide, such as WECO AT-6839.
6Z2000-1	Emery paper, No. 1.
6N8583	Tape TL-83, friction, 3/4".
6G244	Oil, light, such as WECO No. 3 lubricating compound.
6G1325	Oil, such as WECO KS-7470.
7A1200	Oil, light, mineral, spec 6231 (Auto Elec).
6G236.1	Oil, watch, spec 5228 (Auto Elec).
6Z7360	Petroleum spirits, such as WECO KS-7860.
6M750	Orange stick.
6G1516	Paper, bond, such as WECO KS-188 paper.
6Z8626	Polish, metal, paste, Federal spec No. P-P556, type III.
6Z8666	Tape, cleaning, such as WECO KS-6528.
	Toothpicks: hardwood; flat one end; pointed other end.

Note. Gasoline will not be used as a cleaning fluid for any purpose.

### 62. Test Equipment Used But Not Furnished with Switchboards

Signal Corps stock No.	Description
6R38112	Tool Equipment TE-112.
6Z8648-3	Thermometer.
3F4049	Test Set I-49.
3F4181	Test Set I-181.
3F4316.1	Test Set TS-190/U.
3F7127	Multimeter TS-380/U.
3F3570-I	Audio Oscillator TS-379/U.
3F427-2	Decibel Meter TS-399/U.

a. TEST SET I-49. Test Set I-49 (fig. 27) is a portable Wheatstone bridge wired for conveniently making resistance measurements required in telephone systems. Its use is described in TM 11-2019.

b. TEST SET I-181. Test Set I-181 (fig. 28) is a portable current-flow test set used for adjusting relays in a telephone system. Refer to TM 11-2036 for a description of tests which can be made with Test Set I-181.

c. TEST SET TS-190/U (TEST RECEIVER).

(1) Test Set TS-190/U (fig. 29) consists of a 1,000-ohm telephone receiver with a switch-controlled external resistance of 50,000 ohms. The test set is equipped with a three-conductor test cord; two conductors of which are connected to a test pick and a switch in the test pick handle for controlling the external resistance. The other conductor of the test set is terminated in a spring socket chuck to which suitable test clips may be attached. The external resistance of 50,000 ohms is normally in series with the receiver element,

but may be short-circuited by depressing the switch in the handle of the test pick. The external resistance is provided to protect the ears of the user against excessive clicks when testing, and to provide

a high-impedance monitoring receiver so that the test set may be bridged across high-impedance circuits without appreciably affecting the circuit performance. The high-impedance receiver may also be bridged across circuit points without



Figure 27. Test Set I-49.

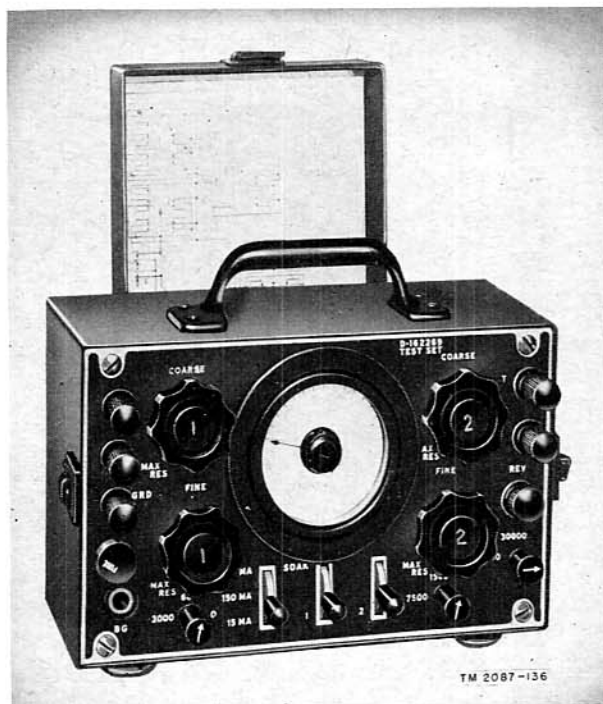

Figure 28. Test Set I-181.

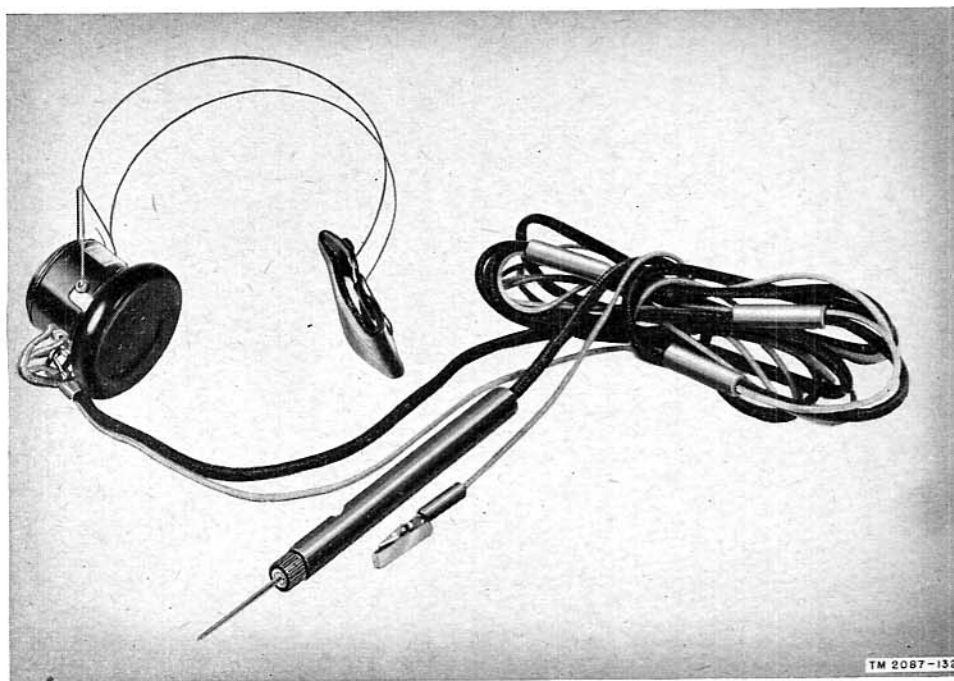

Figure 29. Test Set TS-190/U.

shunting the current sufficiently to cause the relays to release.

- (2) Test Set TS-190/U is designed for maintenance and trouble shooting on telephone and telegraph equipment. Faults such as opens, grounds, shorts, and crosses may be located. When a circuit is completed through the test set between negative bat-

tery and ground (positive battery), a click will be heard in the receiver. If Test Set TS-190/U is not available, any conventional watch case type receiver may be equipped with two test leads and used as a test receiver.

d. MULTIMETER TS-380/U. Multimeter TS-380/U (fig. 30) is a small portable volt-ohm-

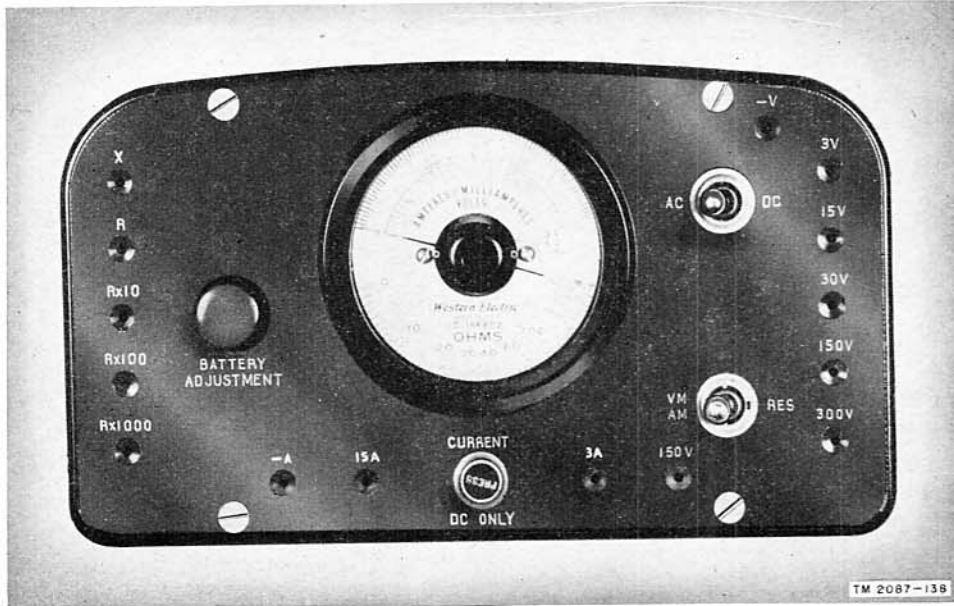

Figure 30. Multimeter TS-380/U.

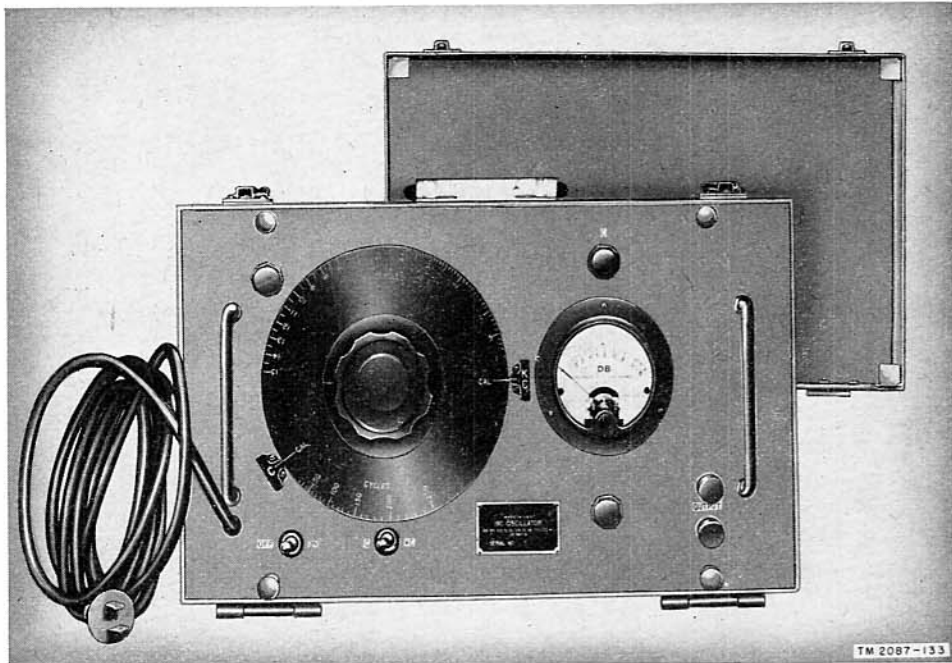

Figure 31. Audio Oscillator TS-379/U.



milliammeter for the measurement of a-c and d-c voltage, dc, and resistance. It is a 2,000 ohms-per-volt meter designed for use with telephone and telegraph equipment. Detailed instructions for use of Multimeter TS-380/U are contained in TM 11-2042.

*e.* **AUDIO OSCILLATOR TS-379/U.** Audio Oscillator TS-379/U (fig. 31) is a heterodyne type vacuum tube oscillator used to provide testing current for transmission measurements. It is capable of supplying an output from -4 dbm (4 db (decibels) below a mw (milliwatt) into 600 ohms) to +6 dbm over a frequency range of from 30 cycles to 15 kc (kilocycles). One control dial serves to vary the frequency continuously over the full range. However, for some uses a greater precision of frequency is desired in a range below 250 cycles for which an expanded scale is provided on the same dial. Operation of the oscillator on the expanded scale is obtained by a switch. The oscillator contains 5 vacuum tubes and has an output impedance of about 600 ohms.

*f.* **DECIBEL METER TS-399/U.** Decibel Meter TS-399/U (fig. 32) is the Western Electric Company 13A transmission measuring set (D-165655) for measuring testing power over the frequency range of 30 cycles to 15 kc; input impedance is approximately 600 ohms. It can be used to

measure received power from -45 db to +10 db. An external source of testing power of 1 mw is required for gain or loss measurements. TM 11-2045 covers the use of Decibel Meter TS-399/U to make transmission measurements.

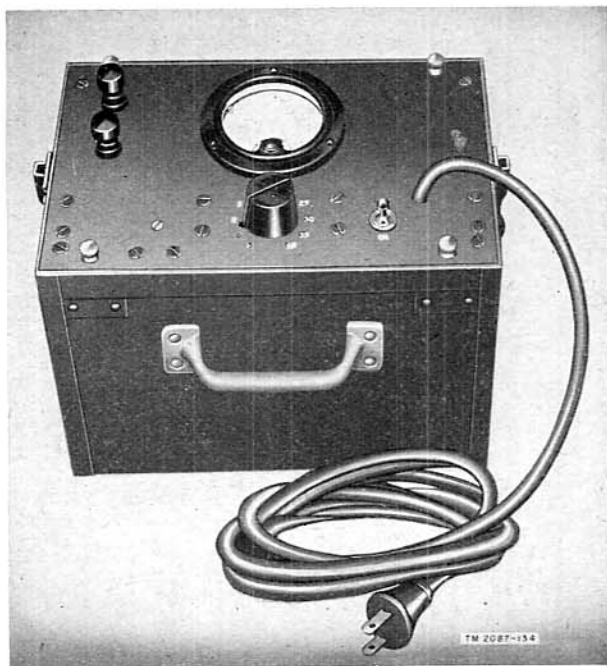

Figure 32. Decibel Meter TS-399/U.

## Section IV. POWER REQUIREMENTS

### 63. Switchboard

The only power required for testing the switchboard is 24 volts dc. This is obtained from the 24-volt storage battery required for common battery operation.

### 64. Test Equipment

*a.* To operate Decibel Meter TS-399/U, 50 watts, 105 to 125 volts ac or dc at 25 to 60 cycles is required.

*b.* The operation of Audio Oscillator TS-379/U

requires 25 watts, 105 to 125 volts ac or dc at 50 to 60 cycles.

*c.* A 4½-volt dry-cell battery is required to operate Multimeter TS-380/U.

*d.* The portable Wheatstone bridge, Test Set I-49, may have three 1½-volt dry cells inserted in space provided in the cabinet or an external battery may be connected to binding posts. When the external battery exceeds 45 volts, a resistance of 10 ohms per volt for each volt in excess of 45 must be connected in series with the battery.

## Section V. INSPECTING, STRIPPING, AND CLEANING

### 65. Repair Inspection

Whenever it becomes necessary to perform extensive repairs on a switchboard, inspect the switchboard thoroughly to determine whether necessary repairs are of such magnitude as will

amount to an almost entire rebuilding of the switchboard. If this is the case, then it is more practicable to replace the switchboard with a new one and salvage usable parts of the old switchboard for storage stock and subsequent repair use.



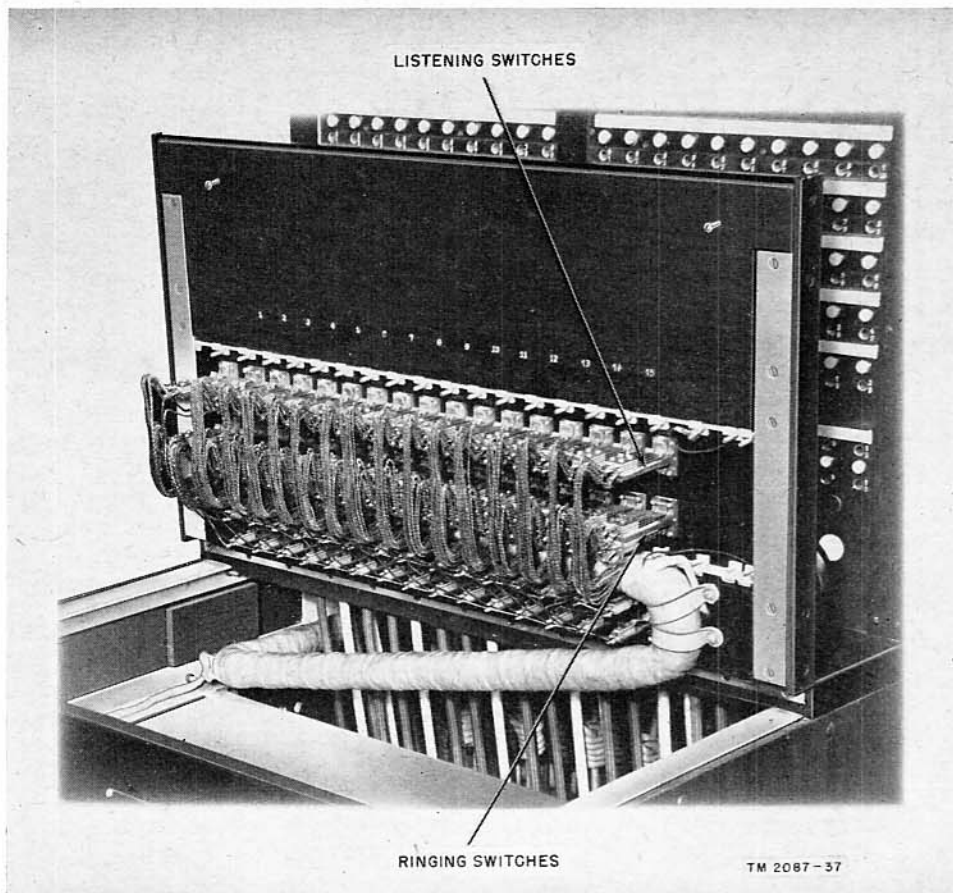

Figure 33. Switch shelf open, showing switches



Figure 34. Wire protection; taping to protect insulation.

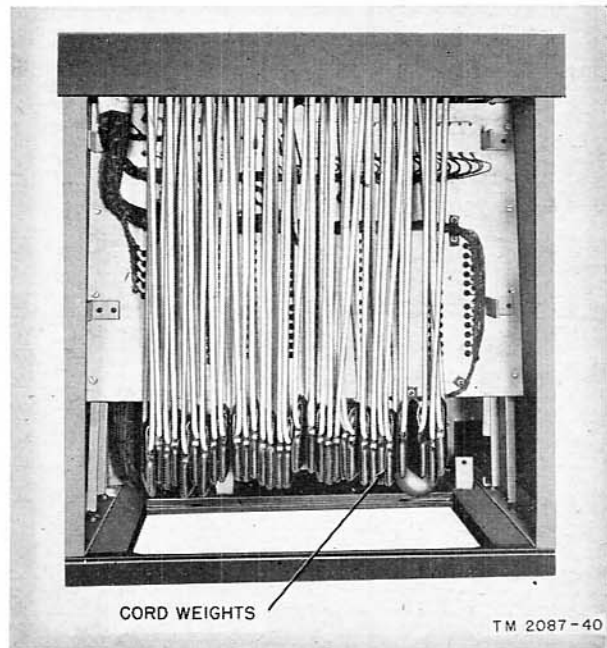

Figure 35. Switchboard cord weights.

## 66. Pertinent Repair Information

Complete instructions on all phases of switchboard repair are contained in TM 11-4301 and TM 11-4302.

*Note.* When cleaning the inside of switch shelves (fig. 33) and between switch contacts with air pressure, be particularly careful to apply air pressure so that dust is blown away from the contacts.

## 67. Wiring and Terminal Lugs

*a.* Watch for moisture and fungus on wiring. If moisture has caused the wire to become brittle and badly discolored, replace the wire, using the discarded wire as a pattern; be sure to follow the same color code. Replace wiring which appears to have become penetrated by fungus.

*b.* How cable forms and skimmers may be protected at points at which they come in contact with metal work is illustrated in figure 34. Tape either the cable form or the metal work.

*c.* Examine terminal lugs (fig. 8) and tighten

them if they appear loose. Remove any film that may affect electrical contact.

## 68. Cord Weights (fig. 35)

*a.* The cord weights must operate freely; this can be determined by feel. Replace defective pulleys.

*b.* Be sure that cord weights do not strike the floor in the cord pit. When cords are not properly seated and the cord weights hit the floor, shorten the cords by making a loop at the cord fastener end.

## 69. Fuses (fig. 9) and Relay Covers

*a.* The fuse panel markings of the Kellogg type switchboard indicate the proper value of fuses to be used. The fuses used are the grasshopper type fuses. The 20 fuses with white beads are the 1½-ampere fuses, and the 5 fuses with the blue beads are the 3-ampere fuses.

*b.* Secure all common and individual relay covers in place. See that the cover designations are correct.

---

## Section VI. TROUBLE LOCATION

### 70. Analysis

*a.* A thorough knowledge of the operation of each circuit of the switchboard is of fundamental importance in analyzing trouble. The troubleshooter must be able to prove quickly whether trouble exists in a particular circuit. The appearance of a failure may indicate the exact location of the faulty adjustment or damage; if not, it will be necessary to determine exactly those functions which are at fault.

*b.* To locate trouble refer to information and data contained in schematic drawings, circuit diagrams, and troubles listed under the operational tests for each circuit. These tests are described in section VII.

*c.* There are two steps in locating trouble in defective equipment. The first is sectionalization and the second is localization.

*d.* If the circuit is not covered in the following

sections, there are no special test procedures or the operation generally duplicates one already given.

### 71. Sectionalization

Sectionalization means tracing the fault to the circuit responsible for faulty operation. Careful observation of switchboard performance may disclose the circuit at fault. It may be necessary, however, to check each circuit for proper operation to locate the one causing trouble.

### 72. Localization

Localization means tracing the fault to a defective part. Some faults can be located by sight, feel, smell, and hearing. The majority, however, must be located by checking voltage, resistance, and continuity. Most troubles can be located rapidly by the operational tests and the troubles listed with the test for each circuit.

## Section VII. FINAL TESTING

### 73. Preparation

Perform operational tests after all repairs have been completed. Quickly check all apparatus for proper adjustment, examine the fuse panel for blown fuses.

### 74. Testing

Test all circuits for function as described in paragraphs 76 through 85. If repairs have been made properly, the electrical requirements will be met except for defects which are not discovered on

negative battery terminal (fig. 36) to the base framework of the relay gate, switch frame, and jack frame. If any one is not grounded, a ground connection must be established.

*c. RINGING CURRENT.* If ringing current is available from a power ringing generator, connect the ringing current leads to the ringing current terminals of the switchboard.

### 76. Cord Test Circuit

*a. GENERAL.* The resistors, switch contacts, and wiring of the cord test circuit are checked by re-

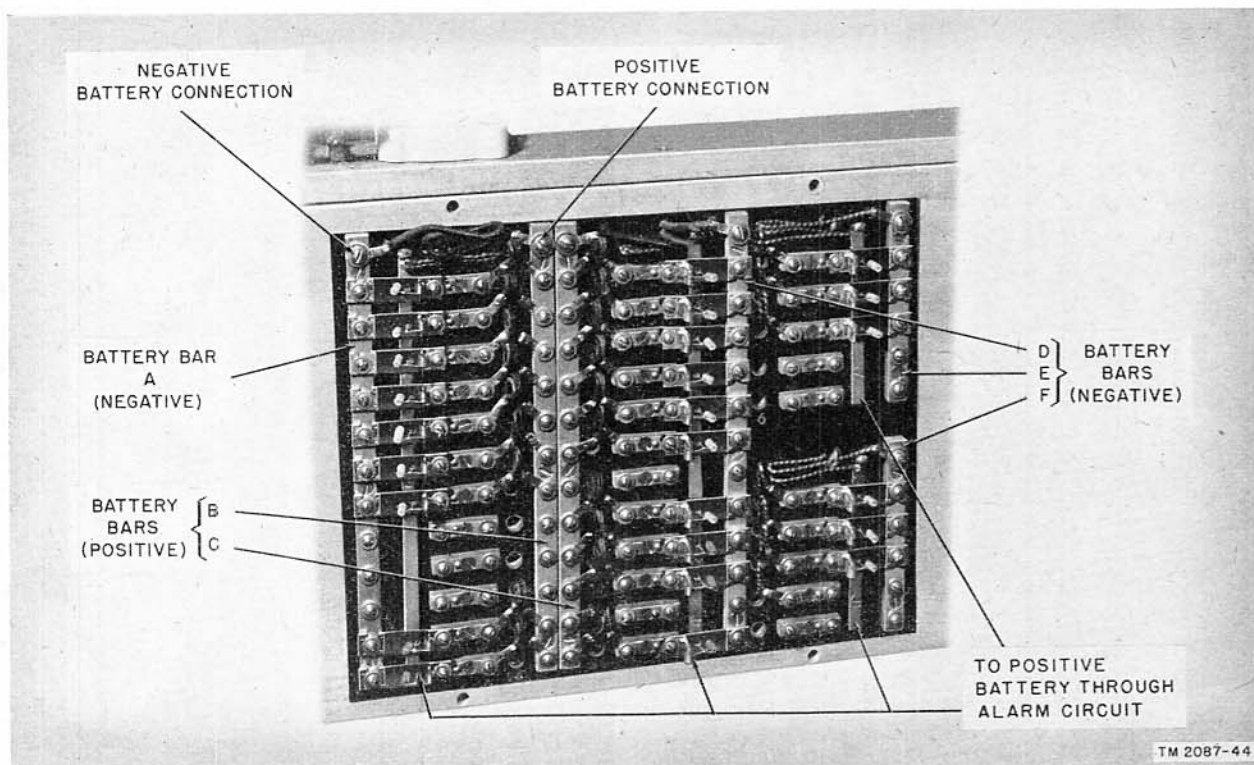

Figure 36. Battery terminals.

visual inspection; these defects will be found by the tests. If all the requirements are met, the equipment will pass final inspection.

### 75. Set-up for Switchboard Tests

*a. BATTERY.* Connect 24-volt battery to the battery terminals and ground the positive terminal. Install all fuses for battery circuits.

*b. GROUND.* To verify that the framework of the switchboard is properly grounded, use Test Set TS-190/U and test for continuity from the

sistance measurements with Test Set I-49. Insert the plug of a test cord connecting the test set into the jack of the cord test circuit to be tested (fig. 37).

*b. COMMON BATTERY CORD TEST CIRCUIT.*

- (1) *Test switch normal.* With the test cord in the common battery test jack, determine the resistance of resistor R (fig. 38). It should be approximately 10,000 ohms. If there is a 15 percent difference, analyze for trouble as follows:

Possible trouble

Analysis

- Open circuits... Open resistor.  
 Open contact of magneto jack springs.  
 Test plug not making contact with tip or ring spring of common battery jack.  
 Open wiring.
- High resistance... Defective resistor.  
 High resistance contact of magneto jack springs.  
 High resistance test plug contact with tip or ring spring of common battery jack.
- Low resistance... Defective resistor.  
 800-ohm resistor T connected through permanently made contact of defective test switch.

(2) *Test switch operated.* With the test switch operated, the resistance of the 800-ohm resistor T in parallel with the 10,000-ohm resistor R should be approximately 740 ohms. If there is a 15 percent difference, analyze for trouble as follows:

Possible trouble

Analysis

- Resistance of 10,000 ohms unchanged... Open test switch contact.
- High resistance... Defective resistor T.  
 High resistance contact of test switch.  
 High resistance contact of common battery jack springs.
- Low resistance... Defective resistor T.

(3) *Testing sleeve grounding.* To verify that the sleeve of the common battery test jack is grounded, use Test Set TS-190/U and test from negative battery to the

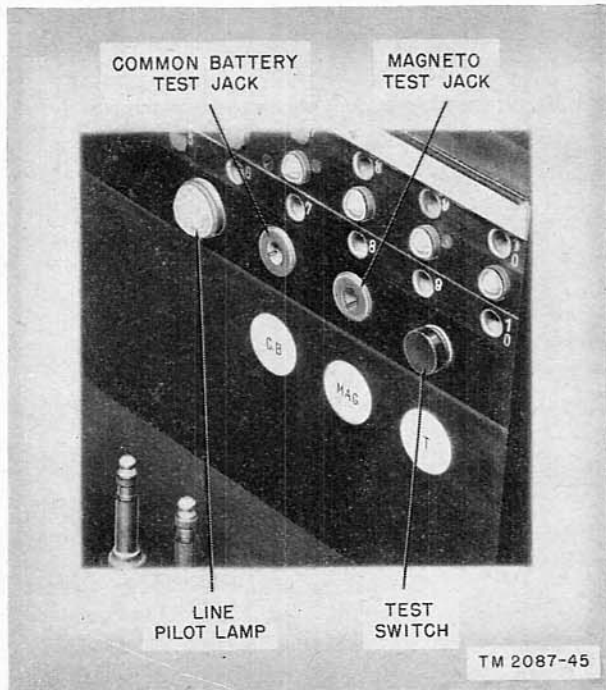

Figure 37. Cord test jacks and switch.

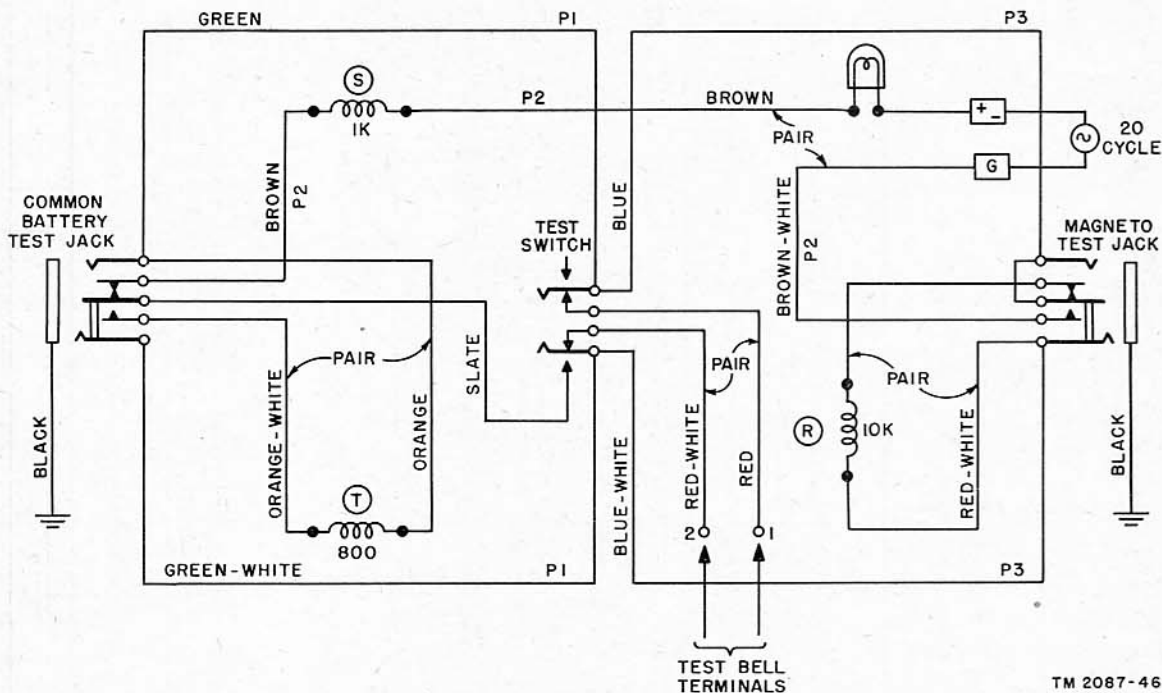

Figure 38. Cord test circuit, wiring diagram.

TM 2087-46



metal sleeve. If it is not grounded, a ground connection must be established.

c. MAGNETO CORD TEST CIRCUIT.

(1) *Preparation of circuit.* If a ringing generator is connected to the switchboard, disconnect the ungrounded lead from the switchboard terminal. Connect the ring-

ing terminals together.

(2) *Resistance measurement.* With the test cord in the magneto jack and the test switch operated, determine the resistance of resistor S. It should be approximately 10,000 ohms. If there is a 15 percent difference, analyze for trouble as follows:

Possible trouble	Analysis
Open circuit-----	Open resistor. Open resistance lamp. Open contact of jack springs of magneto jack or common battery jack. Open test switch contact.
High resistance-----	Defective resistor. High resistance contact of jack springs of magneto jack or common battery jack. High resistance test plug contact with tip or ring spring of magneto jack.
Low resistance-----	Defective resistor.

## 77. Operator's Telephone Circuit

### a. VARISTOR.

(1) *Test of varistor resistance* (fig. 39).

(a) Prepare a varistor test circuit using Multimeter TS-380/U as a 3-volt d-c voltmeter and Test Set I-181 as a milli-ammeter. Open break contacts 3 and 4

of relay 1 by blocking with toothpicks. Refer to TM 11-2042 for test set-ups.

(b) Insert plug of the varistor test circuit into the operator's telephone set jack and insert plug of the varistor test circuit into the jack of Test Set I-181.

(c) Starting with maximum resistance in Test Set I-181, adjust the resistance of the test set until there is a potential of 1½ volts across the varistor, and read the current through the varistor as indicated on the ammeter.

**Caution:** Remove current from the varistor as soon as possible to prevent overheating.

(d) With a potential of 1½ volts across the varistor at the prevailing room temperature, a current value less than shown in the following table of tem-

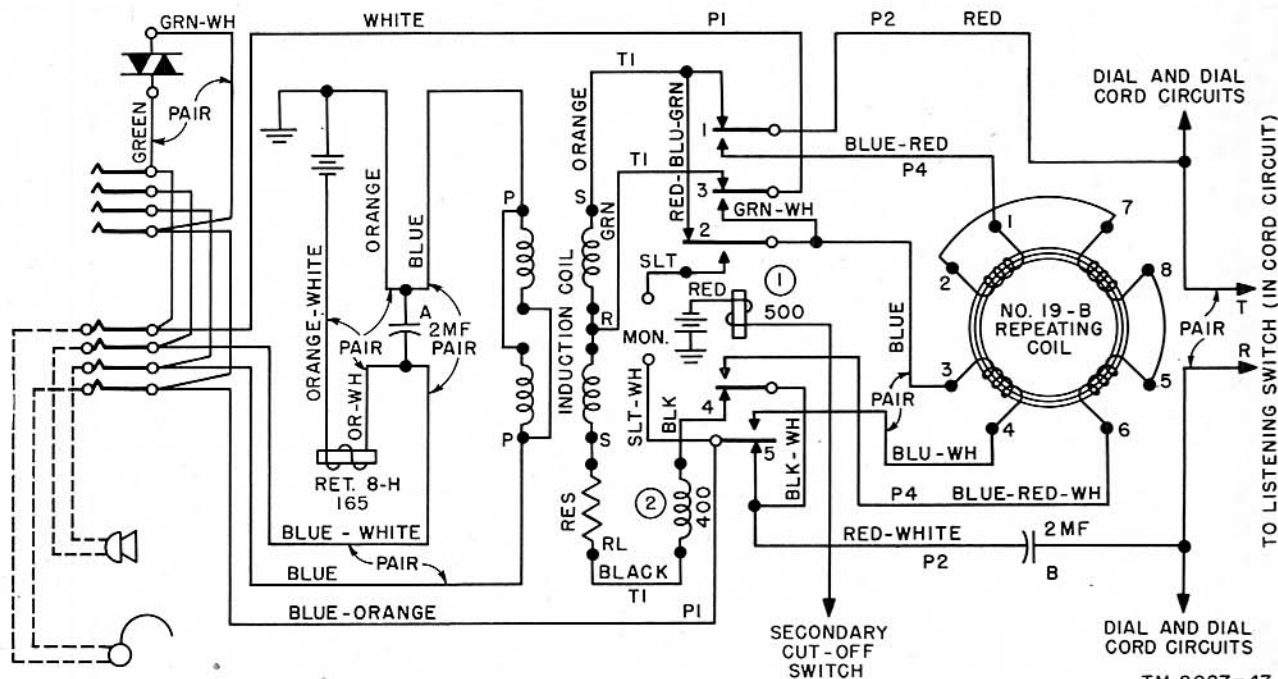

Figure 39. Operator's circuit, wiring diagram.



perature versus current indicates a defective resistor.

*Minimum Current and Temperatures for Varistors*

Room temp ° F.:	Min amp	Room temp ° F.:	Min amp
50.....	0.043	86.....	0.068
52.....	.044	88.....	.069
54.....	.046	90.....	.071
56.....	.047	92.....	.072
58.....	.049	94.....	.074
60.....	.050	96.....	.075
62.....	.051	98.....	.076
64.....	.053	100.....	.078
66.....	.054	102.....	.079
68.....	.056	104.....	.081
70.....	.057	106.....	.082
72.....	.058	108.....	.083
74.....	.060	110.....	.085
76.....	.061	112.....	.086
78.....	.063	114.....	.088
80.....	.064	116.....	.089
82.....	.065	118.....	.090
84.....	.067	120.....	.092

(2) *Test of varistor resistance in reverse direction.* Reverse the connections from Test Set I-181 to plug and repeat tests in (c) and (d) above to check the current flow through the varistor in the other direction.

**b. RECEIVING CIRCUIT AND MONITORING.**

(1) *Test of receiving circuit.*

(a) Connect an operator's telephone set, known to be in good condition, to the telephone jack.

(b) Connect the tip and ring operator's circuit terminals on the terminal board of the connecting jack, through a resistance network to the ringing lead terminals. The 1,000 ohms attenuate the ringing current so that it is heard as ringing tone in the receiver.

(c) If the tone is not heard, analyze for trouble as follows:

Possible trouble	Analysis
Open or cross of tip and ring wiring, contacts, or apparatus.	Check wiring for presence of tone.
Faulty relay 1 contacts----	Check adjustment.

(2) *Test of monitoring connection.* Operate the secondary cut-off switch to establish the monitoring condition.

**78. Cord Circuit (fig. 40)**

Perform these tests on both ends of the cord circuit.

**a. COMMON BATTERY OPERATION OF CORD CIRCUIT.**

(1) *Test of sleeve circuit and relay 1 or 3.*

(a) Connect the answer or call cord to the jack of the common battery cord test circuit.

(b) The cord supervisory answer or call lamp should light indicating that relay 1 or 3 has operated. The circuit for relay 1 or 3 operation is from ground on the sleeve of the jack of the cord test circuit through winding 3-4 of relay 1 or 2 to negative battery. At make contact 3 of relay 1 or 3, the circuit is completed from ground through relay 2 or 4 break contact, the answer or call lamp, and supervisory pilot relay to negative battery.

(c) If the lamp does not light, analyze for trouble as follows:

Possible trouble	Analysis
Relay 1 or 3 not operated----	Check for defective relay, blown fuse, disconnected battery, and open wiring.
Make contact 3 of relay 1 or 3 not closed.	Check adjustment of relay 1 or 3.
Defective lamp-----	Replace lamp.
Falsely operated relay 2 or 4.	Check wiring for cross between tip and ring wires.
Break contact of relay 2 or 4 not making.	Check adjustment of relay 2 or 4.
No battery in lamp circuit---	Check fuse and wiring.
Open winding of supervisory pilot relay.	Check relay.

(2) *Operating test of relay 2 or 4.*

(a) Operating the test switch of the cord test circuit should cause relay 2 or 4 to operate and extinguish the supervisory lamp of the cord being tested.

(b) If the lamp is not extinguished, analyze for trouble as follows:

Possible trouble	Analysis
Relay 2 or 4 does not operate.	Check for open winding 3-4 of relay 2 or 4. Check make contacts 1 and 2 of relay 1 or 3.
Relay 2 or 4 make contacts not closing.	Check adjustment of relay 2 or 4.

(3) *Release test of relay 2 or 4.*

(a) Restoring the test switch to normal should cause relay 2 or 4 to release and light the supervisory lamp again.

(b) If the lamp does not light, analyze for trouble as follows:

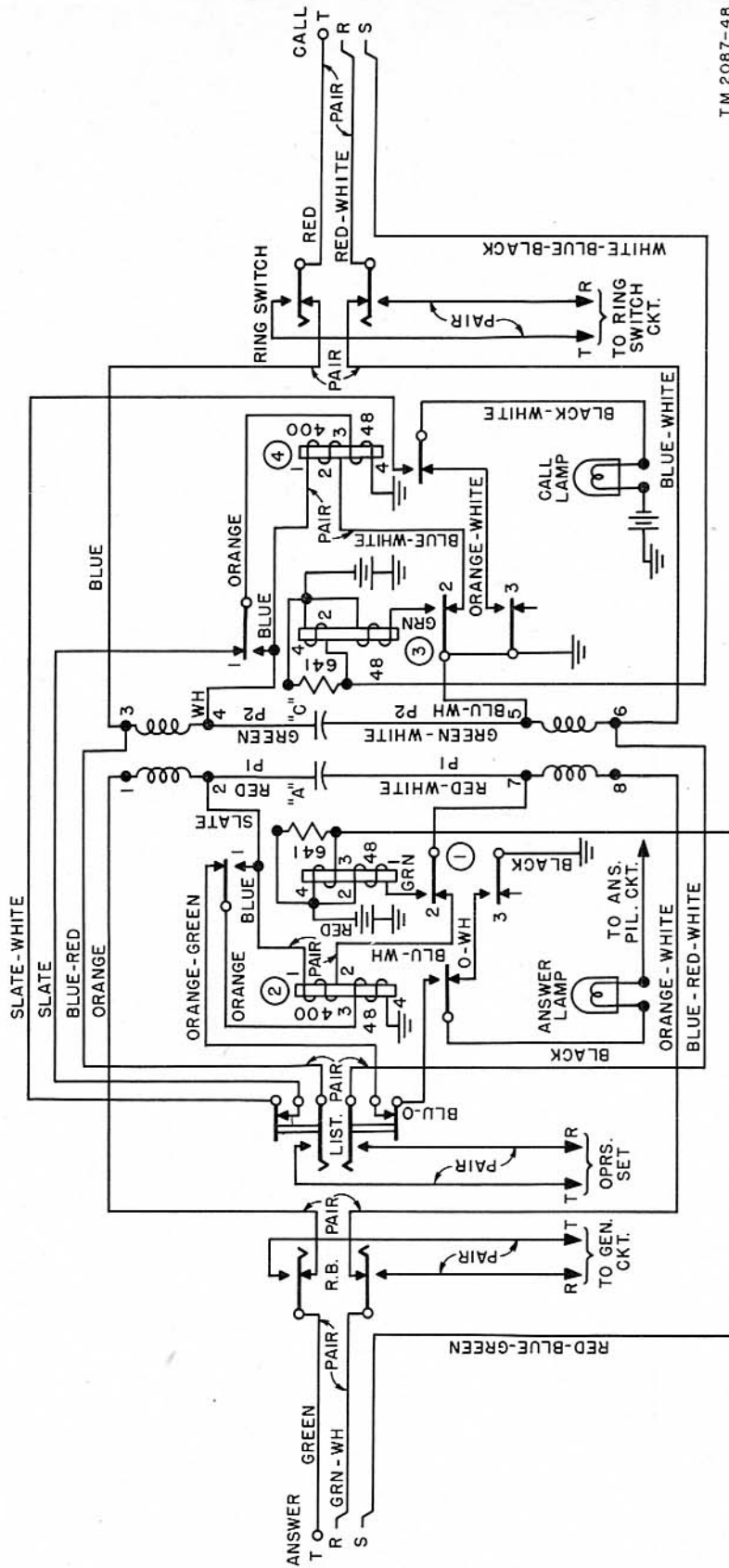

T M 2087-48

Figure 40. Cord circuit, wiring diagram.

<i>Possible trouble</i>	<i>Analysis</i>
Relay 2 or 4 does not release.	Check adjustment of relay 2 or 4.

(4) *Flashing test of relay 2 or 4.*

- (a) Operate and restore the cord test circuit switch at the rate of three times a second. This applies a flashing test to relay 2 or 4 and causes the supervisory lamp to flash.
- (b) The lamp should be extinguished on each operation of the switch and should light again when the switch is restored to the nonoperated position which indicates that relay 2 and 4 operates properly.
- (c) If the lamp fails to respond to the switch operation, analyze for trouble as follows:

<i>Possible trouble</i>	<i>Analysis</i>
Failure of relay 2 or 4 to operate and release at the flashing rate.	Check adjustment of relay 2 or 4.

(5) *Repeating coil test.*

- (a) Terminate a resistance network, such as is used for testing the operator's telephone circuit, on a jack and energize with wiring current.
- (b) Plug either cord of a cord circuit into the jack.
- (c) Ringing tone should be heard across the tip and ring of the plug of the other cord of the cord circuit by using Test Set TS-190/U.
- (d) If ringing tone is not heard, analyze for trouble as follows:

<i>Possible trouble</i>	<i>Analysis</i>
Open in wiring.....	Check continuity of wiring.
Open in repeating coil winding.	Check repeating coil.

(6) *Listening switch talking test.*

- (a) With both cord circuit cords disconnected and the associated listening switch in the operated position, tap the transmitter or blow into the transmitter.
- (b) Listen across the tip and ring of the plug of each cord in turn with Test Set TS-190/U. The tapping or blowing should be heard.
- (c) If the tapping or blowing is not heard, analyze for trouble as follows:

<i>Possible trouble</i>	<i>Analysis</i>
Listening switch make contacts to operator's circuit not closed.	Check adjustment of switch.
Ring switch contacts not closed.	Check adjustment of switch.

(7) *Ringling test.*

- (a) Connect a test bell to the 1 and 2 test bell terminals of the connecting strip on the terminal board.
- (b) Operate the ring-back switch of the answer cord or the ring switch of the call cord depending on which cord is connected to the cord test circuit.
- (c) The test bell should ring.
- (d) Ringing tone should not be heard in the operator's receiver while the listening switch is operated.
- (e) If the bell does not ring or if ringing tone is heard, analyze for trouble as follows:

<i>Possible trouble</i>	<i>Analysis</i>
If bell does not ring:	Check adjustment of
Ring switch make contacts do not close.	switch contacts.
If ringing tone is heard in receiver:	
Ring switch break contacts do not open.	Check adjustment of switch contacts.

*b. MAGNETO OPERATION OF CORD CIRCUIT.* Only those features not tested by common battery operation tests are included in the tests for operation of the cord circuit with magneto telephones.

(1) *Recall test.*

- (a) Connect either the answer or call cord of the cord circuit to the jack of the magneto cord test circuit.
- (b) Operating the magneto cord test circuit test switch energizes winding 1-2 of relay 2 or 4 and causes the relay to operate and close a locking circuit for itself through winding 3-4.
- (c) Operation of relay 1 or 3 is indicated by the lighting of the cord supervisory lamp.
- (d) If the lamp does not light, analyze for trouble as follows:

<i>Possible trouble</i>	<i>Analysis</i>
Relay 2 or 4 does not operate.	Check for short-circuited capacitor A or C.
Open winding 1-2 of relay 2 or 4.	Check winding.
Open wiring.....	Check continuity.

(2) *Listening switch supervisory lamp test.*

- (a) Connect a test cord to the magneto test jack and operate the test switch to light the cord supervisory lamp.
- (b) Operate the listening switch of the cord circuit.
- (c) The supervisory lamp should be extinguished because of its circuit being opened at a break contact of the listening switch.
- (d) If the lamp is not extinguished, analyze for trouble as follows:

<i>Possible trouble</i>	<i>Analysis</i>
Break contact of listening switch does not open.	Check adjustment of switch contact.

## 79. Line Circuit

a. **COMMON BATTERY LINE CIRCUIT** (fig. 41). Operate the night alarm switch to the off position to silence the alarm while testing.

(1) *Ground on line jack sleeve.*

- (a) Connect a cord circuit answer cord to the line jack.
- (b) The answer cord supervisory lamp should light.
- (c) If the supervisory lamp does not light, analyze for trouble as follows:

<i>Possible trouble</i>	<i>Analysis</i>
Ground not connected to sleeve of line jack.	Check ground connection at contact 4 of line relay.
Open in wiring	Check for continuity.
Plug sleeve not making contact with jack sleeve.	Check for dirty line jack sleeve.

(2) *Line relay operation.*

- (a) Connect a 750-ohm resistor across the tip and ring line terminals on the terminal board.
- (b) The line relay should operate as indicated by the lighting of the line lamp.
- (c) If the line lamp does not light, analyze for trouble as follows:

<i>Possible trouble</i>	<i>Analysis</i>
Line lamp burned out	Replace line lamp.
Line relay contact in lamp circuit not closed.	Check relay adjustment.
Line pilot relay winding open	Check relay winding.
Line lamp battery or ground disconnected.	Check for battery and ground.
Line lamp battery fuse blown	Replace fuse.
Line relay not operated	Check for open relay winding.
Line relay battery or ground disconnected.	Check for battery and ground.

<i>Possible trouble</i>	<i>Analysis</i>
Line relay battery fuse blown	Replace fuse.
Line jack spring contacts not closed.	Check for adjustments.
Open in wiring	Check continuity.

(3) *Line relay release.*

- (a) After the line relay has been operated and the line lamp lighted, connect answer cord plug to line jack.
- (b) The line relay should release as indicated by the line lamp being extinguished.
- (c) If the line lamp is not extinguished, analyze for trouble as follows:

<i>Possible trouble</i>	<i>Analysis</i>
Line jack spring contacts not open so that line relay remains operated.	Check adjustment of line jack springs.
Line lamp circuit not opened at line relay contacts 1-2.	Check adjustment of relay contact.

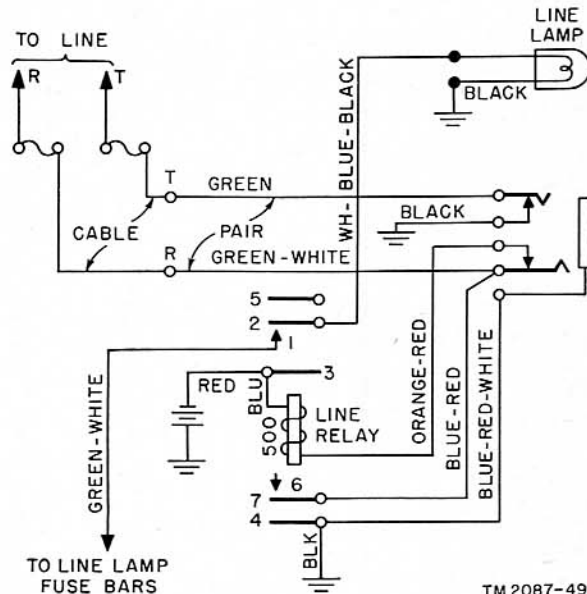

Figure 41. Universal line circuit, showing connection for common battery operation, wiring diagram

b. **MAGNETO LINE CIRCUIT** (fig. 42).

(1) *No ground on line jack sleeve.*

- (a) Connect an answer cord to the line jack.
- (b) The cord supervisory lamp should not light.
- (c) If the cord supervisory lamp lights, analyze for trouble as follows:

<i>Possible trouble</i>	<i>Analysis</i>
Ground connected to line jack sleeve.	Check for ground.

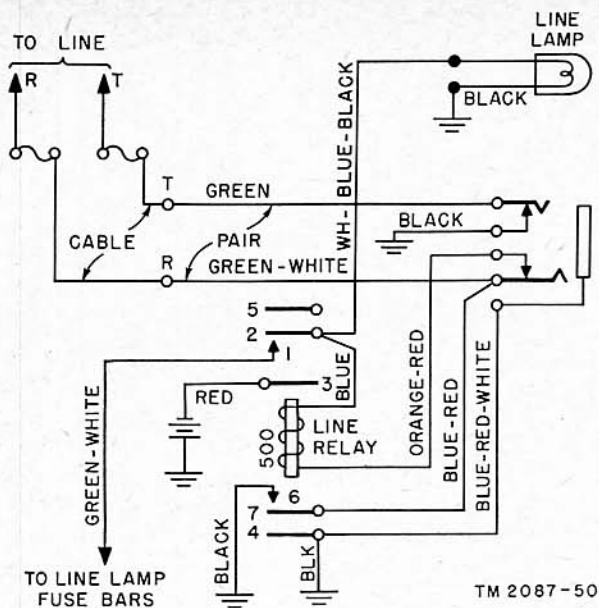

Figure 42. Universal line circuit connected for magneto operation, wiring diagram.

(2) *Line relay operation.*

- (a) Connect ringing current to the tip and ring line terminals on the terminal strip through a 10,000-ohm resistor.
- (b) The line relay should operate as indicated by the lighting of line lamp.
- (c) If the line lamp does not light, analyze for trouble as follows:

Possible trouble	Analysis
Lamp burned out.....	Replace lamp.
Line relay contact 1-2 in lamp circuit not closed to battery.	Check relay adjustment.
Line pilot relay winding open.	Check relay winding.
Line lamp battery fuse blown.	Replace fuse.
Line relay not operated.....	Check for open relay winding.
Battery or ground disconnected from line lamp circuit.	Check for battery and ground.
Line jack contacts not closed.	Check for adjustment.
Open in wiring.....	Check continuity.

- (d) On removing ringing current the line relay should remain operated as indicated by the line lamp remaining lighted.
- (e) If the line lamp does not remain lighted, analyze for trouble as follows:

Possible trouble	Analysis
Relay make contact 6-7 not closed to ground.	Check relay adjustment.

(3) *Line relay release.*

- (a) After the line relay has been operated and the line lamp lighted, connect answer cord plug to the line jack.
- (b) The line relay should release as indicated by the line lamp being extinguished.
- (c) If the line lamp is not extinguished, analyze for trouble as follows:

*Possible trouble*

*Analysis*

Line jack spring contacts not opened so that line relay remains operated. Check adjustment of line jack springs.  
Lamp circuit not opened at contact 1-2 when line relay releases. Check adjustment of relay contact.

### 80. Line Pilot Circuit (fig. 43)

Test the line pilot circuit for both the left and right jack panels. Turn night alarm switch to off position to silence alarm while testing.

a. **LINE PILOT RELAY.** The winding of the line pilot relay is in series with the line lamps, and is tested when a line lamp lights.

b. **LINE PILOT LAMP.**

- (1) When the line lamp lights, the line pilot relay operates and closes a contact which completes the circuit to light the line pilot lamp. The line pilot lamp circuit is from battery through the night alarm relay winding, the line pilot lamp, and the make contact of line pilot relay to ground.
- (2) If the line pilot lamp does not light when the lamp lights, analyze for trouble as follows:

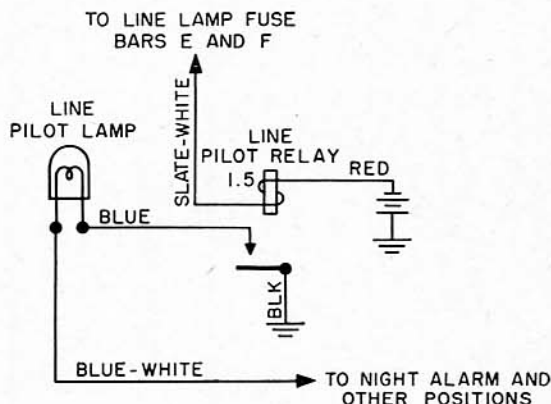

Figure 43. Line pilot circuit.



Possible trouble	Analysis
Line pilot relay make contact not closed.	Check relay adjustment.
Line pilot lamp burned out	Replace lamp.
Battery or ground disconnected from the line pilot lamp circuit.	Check for battery and ground.
Battery fuse blown	Replace fuse.
Open wiring	Check continuity.

## 81. Supervisory Pilot Circuit (fig. 44)

Test the supervisory pilot circuit for operation with cord supervisory lamp of both the answer and call cords of the cord circuits. Turn the night alarm switch to the off position to silence alarm while testing.

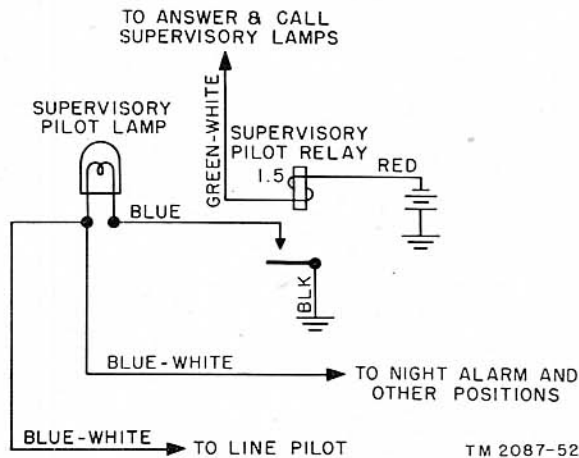

Figure 44. Supervisory pilot circuit, wiring diagram.

**a. LINE PILOT RELAY.** The winding of the supervisory pilot relay is in series with the cord supervisory lamps and is tested when a cord supervisory lamp lights.

**b. SUPERVISORY PILOT LAMP.**

- (1) When the supervisory pilot lamp lights, the supervisory pilot relay operates and closes a contact which completes the circuit to light the cord supervisory lamp. The supervisory pilot lamp circuit is from battery through the night alarm relay winding, supervisory lamp, and make contact of supervisory pilot relay to ground.
- (2) If the supervisory pilot lamp does not light when the cord supervisory lamp lights, analyze for trouble as follows:

Possible trouble	Analysis
Supervisory pilot relay contact not closed.	Check relay adjustment.

Possible trouble	Analysis
Supervisory pilot lamp burned out.	Replace lamp.
Battery or ground disconnected from supervisory pilot lamp circuit.	Check for battery and ground.
Battery fuse blown	Replace fuse.
Open wiring	Check continuity.

## 82. Night Alarm Circuit (fig. 45)

**a. NIGHT ALARM RELAY.** The winding of the night alarm relay is in series with the line pilot lamps and cord supervisory pilot lamps and is tested at the same time.

**b. ALARM BELL.**

- (1) The night alarm switch should be operated to the on position so that the night alarm bell will ring for testing.
- (2) When a line pilot lamp or a cord supervisory lamp lights, the alarm relay operates and closes a contact which completes the alarm bell circuit. The circuit is from battery through the D and C (for dc) terminals, a night alarm switch contact, a make contact of the night alarm relay, and another night alarm switch contact to ground.
- (3) The ringing of the night alarm bell is evidence of satisfactory operation of the night alarm circuit.
- (4) If the bell does not ring, analyze for trouble as follows:

Possible trouble	Analysis
Battery or ground disconnected.	Check for battery and ground.
Battery fuse blown	Replace fuse.
Make contact of night alarm relay does not close.	Check relay adjustment.
Night alarm switch contact does not close.	Check switch adjustment.
Open winding D-C of bell	Check for continuity.
Bell contacts not making or breaking.	Check adjustment of bell.
Open wiring	Check continuity.

## 83. Fuse Alarm Pilot Circuit (fig. 46)

When a fuse blows in the Kellogg switchboard, a fuse alarm pilot lamp lights.

**a.** Operate the fuse alarm switch to disconnect the fuse alarm buzzer and to light the fuse alarm pilot lamp. The lighted lamp provides a continuous warning that a fuse requires replacing after which the fuse alarm switch must again be returned to normal so that the circuit will again function when a fuse blows.

b. If the fuse alarm lamp does not light, analyze for trouble as follows:

Possible trouble	Analysis
Lamp burned out.....	Replace lamp.
Fuse alarm switch contacts not closed to battery or ground.	Check adjustment of switch contacts.
Battery or ground disconnected.	Check for battery and ground.
Battery fuse blown.....	Replace fuse.
Open in wiring.....	Check continuity.

c. Have fuse alarm switch in normal position so that the fuse alarm relay and the fuse alarm buzzer are connected.

d. On the fuse panel connect a negative battery fuse bar to its associated alarm bar by using a jumper or by installing a blown fuse. This completes the fuse alarm pilot lamp circuit and the

lamp should light. The circuit is from the negative battery fuse bar through the alarm bar current limiting resistor, the fuse alarm pilot lamp, and the fuse alarm relay winding to ground.

e. If the fuse alarm pilot lamp does not operate analyze for trouble as follows:

Possible trouble	Analysis
Contact of fuse alarm switch not closed.	Check adjustment of contacts.
Open resistor.....	Check resistor.
Open fuse alarm relay windings.	Check relay.
Ground disconnected from fuse alarm relay.	Check ground.

### 84. Fuse Alarm Circuit (fig. 47)

When a fuse blows it causes a fuse alarm buzzer to operate.

a. When the fuse alarm pilot lamp lights, the fuse alarm relay operates to complete the fuse alarm buzzer circuit from ground through the d-c winding to battery. The buzzer should sound an alarm to indicate that a fuse has blown.

b. If the buzzer alarm does not sound, analyze for trouble as follows:

Possible trouble	Analysis
Battery or ground disconnected from buzzer.	Check for battery and ground.
Fuse alarm relay contact not closed.	Check adjustment of relay contact.
Battery fuse blown.....	Replace fuse.
Open buzzer winding.....	Check winding.
Buzzer contacts not making or breaking.	Check adjustment of buzzer.
Open wiring.....	Check continuity.

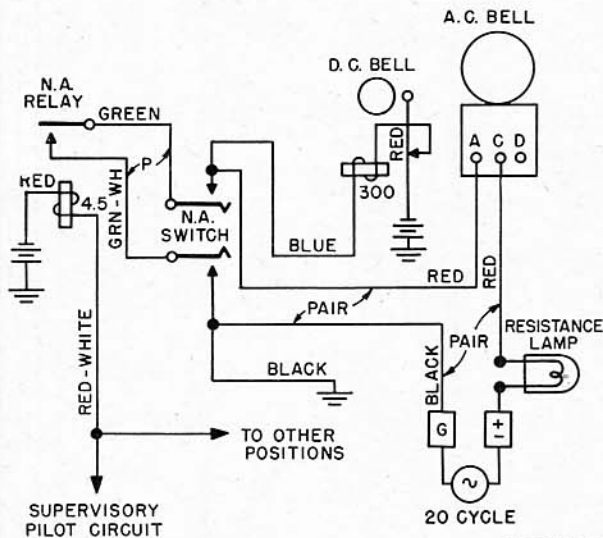

Figure 45. Night alarm circuit, wiring diagram.

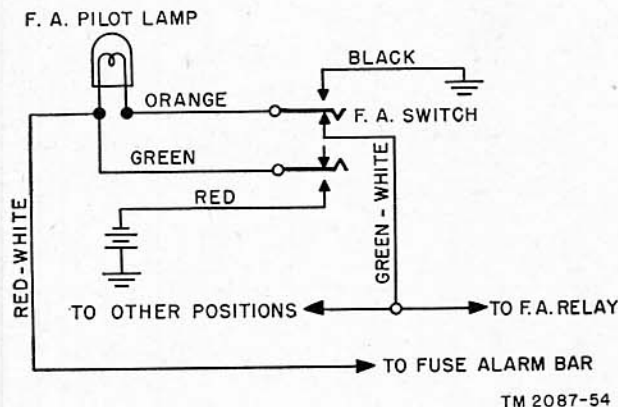

Figure 46. Fuse alarm pilot circuit, wiring diagram.

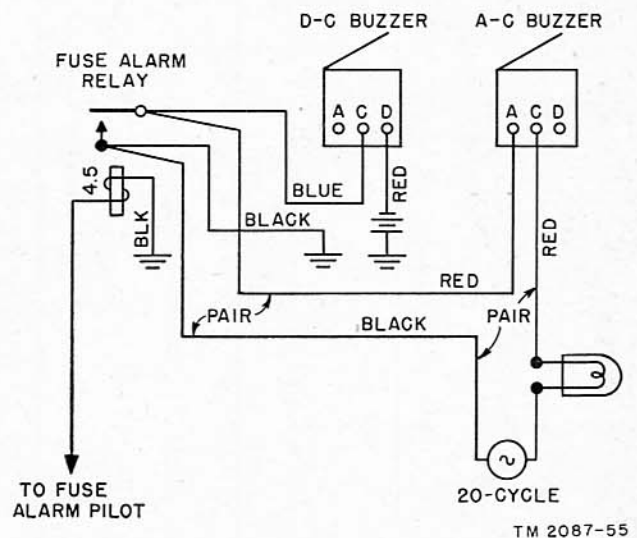

Figure 47. Fuse alarm circuit, wiring diagram.

## 85. Trunk Circuit (fig. 48)

### a. CALL TO ANOTHER EXCHANGE.

#### (1) Relay 3 operation.

- (a) Connect call cord to trunk line jack.
- (b) Relay 3 should operate.
- (c) If relay 3 does not operate, analyze for trouble as follows:

Possible trouble	Analysis
Relay winding open-----	Check winding.
Battery or ground disconnected.	Check for battery and ground.
Fuse blown-----	Replace fuse.
Trunk line jack spring contact not closed.	Check jack spring adjustment.
Break contact of relay 1 not closed.	Check relay adjustment.
Open in wiring-----	Check continuity.

#### (2) Repeating coil test.

- (a) Leave the call cord connected to the trunk jack.
- (b) Connect operator's telephone set to operator's jacks and operate listening switch.
- (c) Tap transmitter or blow into receiver.
- (d) Tapping or blowing should be heard by listening across the tip and ring trunk terminals on the terminal board with Test Set TS-190/U.

- (e) If tapping or blowing is not heard, analyze for trouble as follows:

Possible trouble	Analysis
Tip or ring springs not making contact with plug.	Check jack springs.
Open repeating coil winding between terminals 1 and 8.	Check repeating coil.
Open in wiring to line jack---	Check continuity.
Break contacts 1 and 2 of relay 4 not closed.	Check relay adjustment.
Make contacts 1 and 2 of relay 3 not closed.	Check relay adjustment.
Open repeating coil winding between terminals 3 and 6.	Check repeating coil.
Open in wiring from terminal board to repeating coil.	Check continuity of wiring.

#### (3) Relay 4 operation.

- (a) Connect the dial cord to the trunk dial jack.
- (b) Relay 4 should operate.
- (c) If relay 4 does not operate, analyze for trouble as follows:

Possible trouble	Analysis
Relay 4 winding open-----	Check relay winding.
Battery disconnected from relay 4.	Check for battery.
Relay 4 battery fuse blown---	Replace fuse.

- (d) When relay 4 operates, break contacts 1 and 2 should disconnect the trunk circuit equipment.

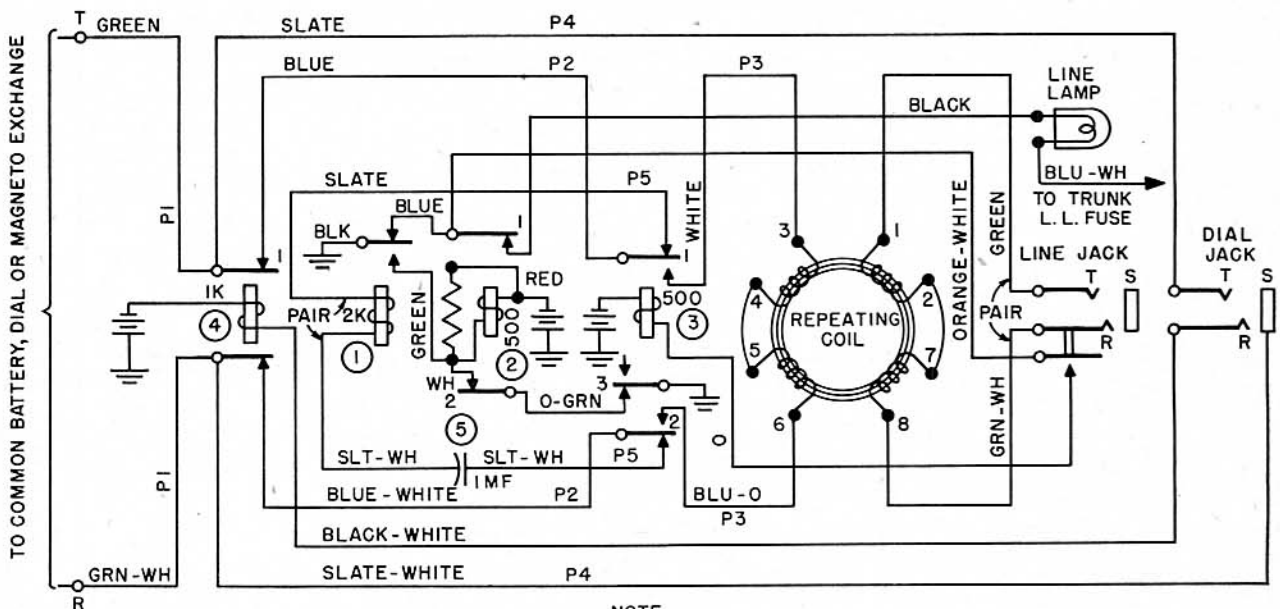

NOTE  
DIAL CORD IN OPERATORS  
CIRCUIT. T & S ARE  
DIAL CONDUCTORS. R  
IS SWITCHING CONDUCTOR.

TM 2087-56

Figure 48. Universal trunk circuit, wiring diagram.

(e) Test for contacts 1 and 2 being open by ringing on a call cord connected to the trunk line jack and listening across the tip and ring terminals of the trunk line on the terminal board with Test Set TS-190/U.

(f) If the ringing tone is heard, analyze for trouble as follows:

<i>Possible trouble</i>	<i>Analysis</i>
Break contact 1 and 2 remained closed when relay 4 operated.	Check adjustment of relay 4.

**b. CALL FROM ANOTHER EXCHANGE.**

**(1) Operation of relay 1 and 2.**

(a) Connect ringing current through a 10,000-ohm resistor to the tip and ring trunk terminals on the terminal board.

(b) Relay 1 operates, followed by the operation of relay 2, as is indicated by the trunk line lamp lighting.

(c) If lamp does not light, check for trouble as follows:

<i>Possible trouble</i>	<i>Analysis</i>
Relay 1 winding open-----	Check relay.
Make contact of relay 1 does not close.	Check relay adjustment.
Wiring to relay 1 open-----	Check for continuity.
Make contact of relay 1 does not close to complete relay 2 circuit.	Check adjustment of relay 1.
Relay 2 winding open-----	Check relay.
Make contact 2 of relay 2 does not close to complete locking circuit for relay 2.	Check adjustment of relay 2.
Break contact 3 of relay 3 does not close to complete locking circuit for relay 2.	Check adjustment of relay 3.
Battery disconnected from relay 2.	Check for battery.
Blown fuse in relay 2 battery circuit.	Replace fuse.
Relay 1 does not release after ringing current is removed so that lamp circuit is open to ground at the break contact of relay 1.	Check adjustment of relay 1.
Trunk line lamp burned out--	Replace lamp.
Trunk line lamp battery disconnected.	Check for battery.
Trunk line lamp battery fuse blown.	Replace fuse.
Open wiring in lamp circuit---	Check continuity.

**(2) Release of relay 2.**

(a) While trunk line lamp is lighted, connect an answer cord to the trunk line jack.

(b) Relay 3 operates and at break contact 3 opens the locking circuit of relay 2 which releases as is indicated by the trunk line lamp being extinguished.

(c) If the trunk line lamp is not extinguished, analyze trouble as follows:

<i>Possible trouble</i>	<i>Analysis</i>
Break contact 3 of relay 3 does not open locking circuit of relay 2.	Check adjustment of relay 3.
Make contact 1 of relay 2 does not open trunk line lamp circuit.	Check adjustment of relay 2.

**86. Dial and Dial Cord Circuit (fig. 49)**

**a. OPERATION OF RELAY 3.**

(1) Connect battery through a 750-ohm resistor to the tip terminal and connect ground to ring terminal of the trunk on the terminal board. Relay 3 should operate and connect the operator's telephone circuit.

(2) Connect an operator's telephone set to the operator's jacks.

(3) Tap transmitter or blow into transmitter with the listening switch in the normal position.

(4) The tapping or blowing should be heard in Test Set TS-190/U connected across the trunk tip and ring terminals on the terminal board.

(5) If the tapping or blowing is not heard, analyze for trouble as follows:

<i>Possible trouble</i>	<i>Analysis</i>
Relay 3 coil open so that relay 3 does not operate.	Check relay 3 winding.
Make contacts 1 and 2 of relay 3 not closed.	Check adjustment of relay 3.
Break contacts 1 and 2 of relay DR not closed so that relay 3 cannot operate.	Check adjustment of relay DR.
Open in wiring-----	Check continuity.

**b. OPERATION OF RELAY DR AND RELEASE OF RELAY 3.**

(1) With battery and ground connected for testing the operation of relay 3, move the dial off normal. A dial spring make contact completes a circuit to ground for the operation of relay DR.

(2) The opening of break contacts 1 and 2 by relay DR operating causes relay 3 to release and open the connection to the operator's telephone circuit.

- (3) To determine whether the operator's telephone circuit has been disconnected, connect an operator's set to the jacks and tap or blow into the transmitter.
- (4) The blowing or tapping should not be heard in Test Set TS-190/U connected across the tip and ring terminals on the terminal board.
- (5) If tapping or blowing is heard, analyze for trouble as follows:

<i>Possible trouble</i>	<i>Analysis</i>
Make contacts of relay 3 not opened.	Check adjustment of relay 3.
Break contacts 1 and 2 of relay DR not opened so that relay 3 does not release.	Check adjustment of relay DR.
Dial spring make contact not closed so that relay DR does not operate.	Check dial spring adjustment.

#### c. DIAL OPERATION.

- (1) With battery and ground connected for testing the operation of relay 3, operate the dial for the zero digit and then release.
- (2) With Test Set TS-190/U connected across the trunk tip and ring terminals on the terminal board, dial pulse clicks should be heard because of the dial contacts closing and opening.

- (3) Relay DR is of the slow-release type and remains operated during the train of dial pulses.
- (4) If the dial clicks are not heard, analyze for trouble as follows:

<i>Possible trouble</i>	<i>Analysis</i>
Make contacts 1 and 2 of relay DR not closed.	Check adjustment of relay DR.
Dial contacts not closing and opening.	Check adjustment of dial contacts adjustment.
Capacitor D shorted which completes short circuit across dial contacts and renders contacts ineffective for transmitting dial pulses.	Check capacitor for short circuit.
Battery or ground disconnected from relay DR circuit.	Check for battery and ground.
Battery fuse blown.....	Replace fuse.
Open in wiring.....	Check continuity.

#### d. DIAL CONTACT SPARKING.

- (1) With battery and ground connected for testing the operation of relay 3, observe the dial contacts while opening and closing.
- (2) If dial contact sparking or arcing is observed, analyze for trouble as follows:

<i>Possible trouble</i>	<i>Analysis</i>
Open capacitor D.....	Check capacitor.
Open resistor DS.....	Check resistor.
Open wiring.....	Check continuity.

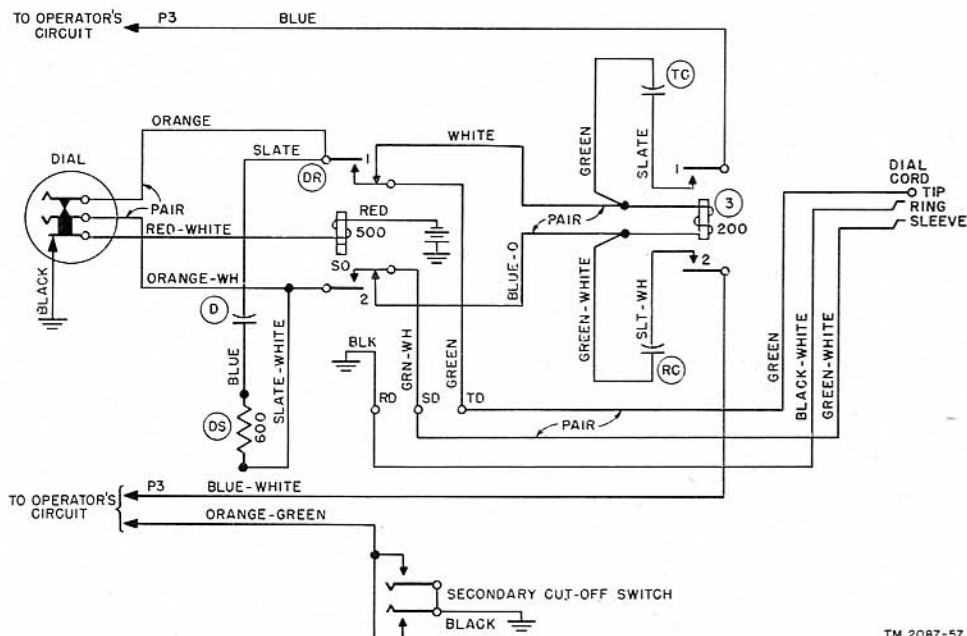

Figure 49. Dial and dial cord circuit, wiring diagram.

TM 2087-57



## Section VIII. APPARATUS ADJUSTMENTS AND REQUIREMENTS

### 87. Removal and Replacement of Parts

When trouble has been localized to a specific unit or circuit, it is necessary to gain access to the defective part for inspection, adjustment, or replacement. All parts are accessible either directly or by disassembly. If wires are to be removed, identify and tag each wire and its terminal. Replace any wire which has become accidentally detached; refer to the schematic and wiring diagrams for that specific assembly. Information given in the following paragraphs covers the removal of those units that require special means and certain precautions. The plug and jack connected to the operator's telephone set and the spring clip attached to the dial are the only parts that are detachable without some disassembly procedure.

### 88. Line Jacks and Line Lamp Jacks

Line jacks and their associated line lamp jacks are mounted in separate strips of 10 each. A strip of line lamp jacks is mounted directly above a strip of line jacks. To clean the contacts, adjust the springs or clean any one jack, the strip of 10 with which it is mounted must be removed from the switchboard. This requires unsoldering all wire connections on the jack strip and the removal of the short ground wire from the strip of line lamp jacks to the strip of line jacks. If a switchboard is in service and there are spare line facilities available, it may be better to transfer the line involved to the unused or spare equipment, rather than to attempt repairs at that time. In removing a strip, its attached wires, as well as those of the strips above and below, may be considerably bent and disturbed, and the repair, if hastily or carelessly done, may create additional trouble by breaking wire connections and disturbing contact adjustments.

### 89. Switches and Switch Shelf

A faulty switch may be adjusted while it is fastened to its mounting plate. If it is necessary to replace a switch, unsolder one wire at a time from the faulty switch and solder it to the like contact on the new switch. After all wires have been transferred to the new switch, remove the old switch from the mounting plate and install the

new switch. A switch is removed from its mounting plate by loosening the plate mounting screws, thus freeing the clamps underneath so that they may be disengaged (fig. 50). By raising the switch shelf to expose the clamps, a switch may be guided as it is withdrawn. To remove a switch, remove the screws that attach it to the mounting plate.

### 90. Hand Generator

The hand generator may be removed from the under side of the cord shelf for adjustment or repair. To remove the generator, first remove the wires from it, then unscrew the crank at the front end of the switch shelf by turning in a counterclockwise direction while its extension shaft is held stationary. Then turn the extension shaft that the crank is mounted on in a counterclockwise direction to unscrew and withdraw it through the opening in the front panel. By the removal of the two screws that secure the generator to the cord shelf, the generator is freed.

### 91. Cords and Plugs

*a.* Because of constant use and wear, it is often necessary to make repairs or replacements of cords and plugs. These repairs include removal of frayed portions of cord, replacement of excessively worn plugs and broken plug shells, and the tightening of plug and cord connections.

*b.* Cord and plug repairs on switchboards in service must be made during periods of light traffic.

*c.* For a detailed description of cord and plug repair procedures, refer to TM 11-473.

### 92. Switches and Jacks

Section III of chapter 3 of TM 11-4302 describes in detail the repair procedures for Kellogg lever type switches. Section II of chapter 4 of TM 11-4302 covers repair procedures for Kellogg type jacks.

### 93. Dials

Automatic Electric Company dials are used on the Kellogg type Switchboard SB-53( )/FTC. Repair procedures for this type dial are covered in detail in chapter 9 of TM 11-4302.

## 94. Relays

Refer to chapter 2 of TM 11-4302 for general information on relays and to *a* through *e* below for specific information covering Kellogg relays used in Switchboard SB-53( )/FTC. Unless otherwise specified, the information given here is applicable to all Kellogg relays. Check relay table at the end of this paragraph for specifications differing from general requirements given.

*a. CONTACT SPRING ALINEMENT.* Examine the springs to be sure that they are free of sharp bends and kinks. If they are not, straighten them whenever possible. Be careful not to bend the springs excessively. Such bending leads to crystallization of the metal and breakage. If the springs are not even and the contacts are not centered when the relay makes, loosen the spring pile-up assembly screws and reset the springs. Gage by eye. When adjusted, reset the assembly screws securely.

*b. ARMATURES.*

(1) *Residual air gap with fixed pins.* The residual air gap on armatures with fixed, nonadjustable pins should be approxi-

mately 0.010 inch. If the gap does not meet the requirements, replace the armature of the relay.

- (2) *Residual air gap with adjustable pins.* Constant service relays may require adjustment to compensate for wear and to vary the release timing. A large gap will result in rapid operation. The air gap on relays with adjustable residual pins should be 0.010 inch nominal unless otherwise shown in relay tables. Make adjustments by releasing the pin-locking nut on the armature and resetting the pin to meet requirements. Reset the locknut securely. Use a feeler gage.
- (3) *Armature travel.* Armature travel should be 0.010 inch to 0.015 inch minimum. Check relay tables for specific requirements on special relays. To adjust, remove the self-locking nut that retains the armature to the heel plate and slip the armature off the retaining pin. During removal and replacement, be careful not to damage the lever springs under which

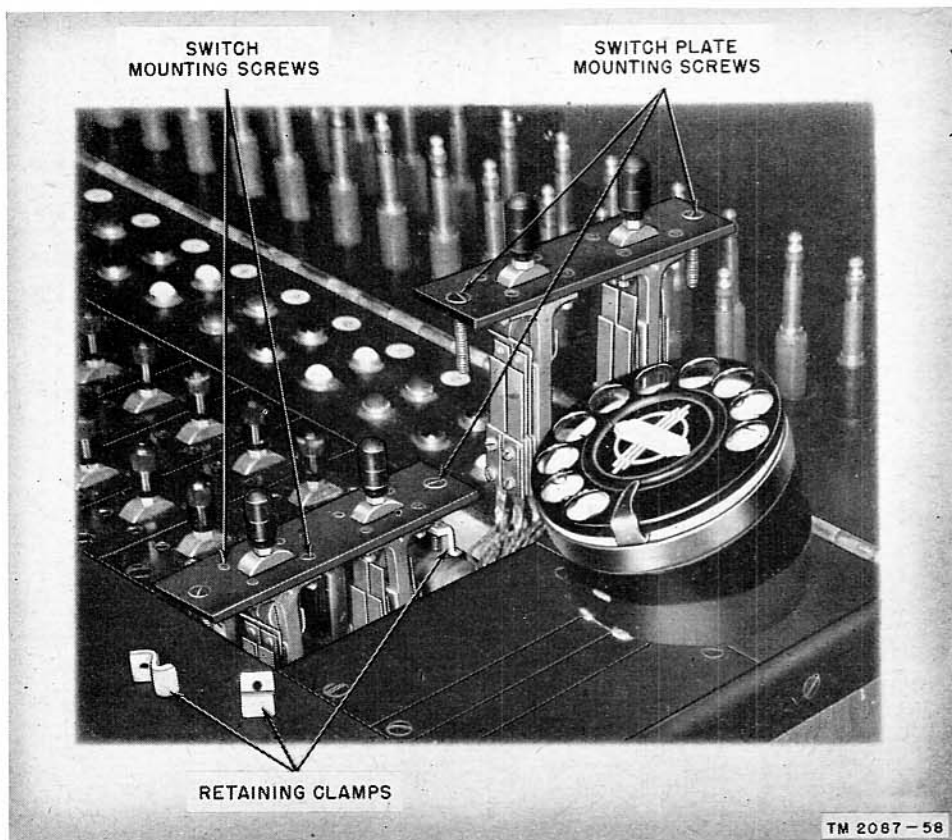

Figure 50. Switch plate mounting screws and retaining clamps.

the armature is seated. Bend the armature as required and replace. Replace the self-locking screw and tighten until the armature is moved against the lever springs. Back the locknut off until the armature is fully open and free armature travel is assured.

**c. CONTACT ADJUSTMENTS.**

(1) *Spring combination identification* (fig. 51). The relay heel plate is sufficiently wide to accommodate three stacks of contact springs. Viewed from the rear (terminal end) of the relay with the coil down, the stacks or piles are lettered from left to right as C, B, and A. The spring combinations consist of sets of two or three springs including a lever spring. The spring contact combinations are numbered from left to right and from bottom to top. The combination at the bottom (next to the heel plate) of the C stack is number 1, the one at the bottom of the B stack is 2, and the one at the bottom of the A stack becomes 3. Numbering continues from the C or left-hand stack with the combination over the bottom one, which becomes 4. Numbering is consecutive and, if a stack is omitted, the number is assigned to the next combination.

(2) *Spring tension.*

(a) The spring tensions listed in the relay tables in *e* below represent the proper tension to lift a lever spring from its nonoperated position. All tensions

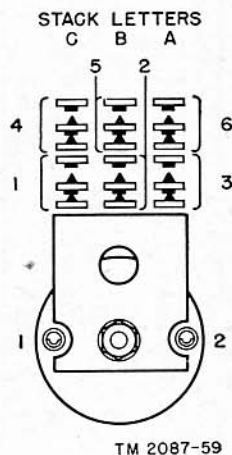

TM 2087-59

Figure 51. Spring pile-up identification diagram for Kellogg relays, terminal end view.

given are in grams and are used both for make and break springs, against lever springs, and spring stops. Measurements are taken with a gram gage, with the gage spring held as closely to the spring contact as possible.

(b) In special relays when spring tension is not specified, the proper settings are related to and dependent on armature travel. The table below gives spring tension requirements for unlisted relays.

Spring tension	Armature travel
10 to 15 grams	0.010 inch to 0.015 inch
15 to 20 grams	0.015 inch to 0.020 inch
20 to 25 grams	0.020 inch to 0.025 inch

(c) Make spring tension adjustments by bending the springs at a point near their bases, using the No. 58 or No. 60 spring bender.

(3) *Contact separation.*

(a) *Make contact assembly* (fig. 52). The separation between the lever spring L and the make spring MS should be—  
Minimum 0.005 inch  
Maximum 0.010 inch

The MS spring and contact should follow with L, 0.003 inch after making contact.

(b) *Break contact assembly* (fig. 53). When fully operated, the contact of lever spring L should clear the break spring BS contact by—  
Minimum 0.005 inch  
Maximum 0.010 inch

The BS spring should rest solidly against the stop and not move at any time during the operating cycle.

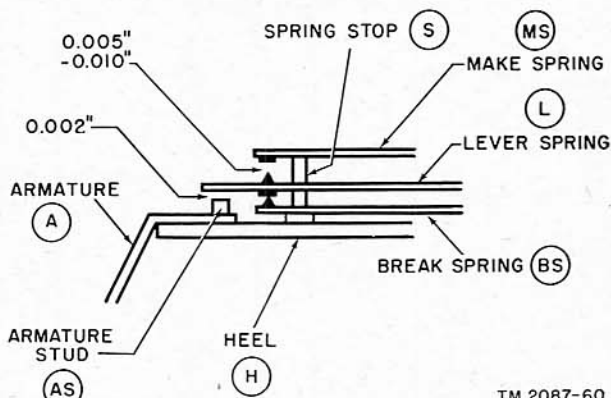

TM 2087-60

Figure 52. Make contact, normal position.

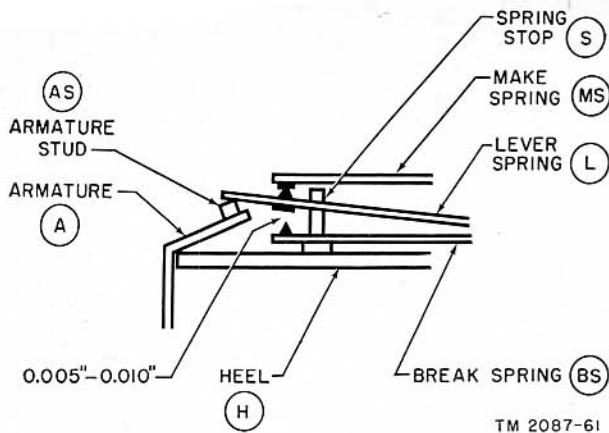

Figure 53. Break contact, operated position.

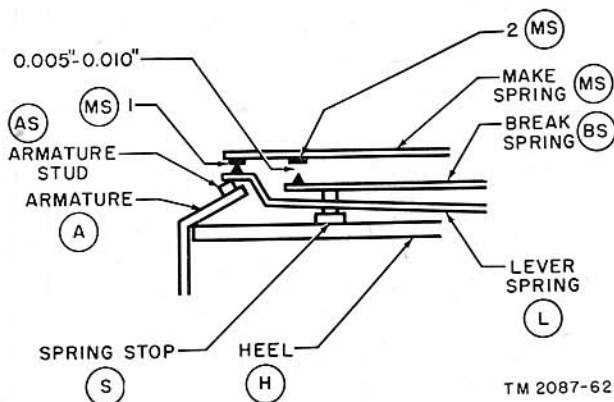

Figure 54. Make-before-break combination, operated position.

(c) *Lever spring* (fig. 52). When in normal position, the lever spring L should have a separation of 0.002 inch minimum from the armature stud AS.

(d) *Make only or break only assemblies* (fig. 52). A make only or break only unit is the same as a regular make assembly with the omission of the BS and MS springs and contacts, respectively. Refer to make contact assembly data above.

(e) *Make-before-break assembly* (fig. 54). The L spring contact makes with the MS spring contact 1 before the MS spring contact 2 breaks from the BS spring contact. With the relay unoperated, the separation between the L spring contact and the MS spring contact 1 should be—

Minimum 0.005 inch

Maximum 0.010 inch

With the relay operated, the separation

between the BS spring contact and the spring contact 2 should be the same.

(f) *Multiple unit assembly* (fig. 55). The break assembly data covered above is applicable to the multiple unit with the following exception. If the break springs BS1 or BS2 and their contacts are omitted from the assembly, the lever spring L1 should be tensioned against the carrier bushing CB.

d. **ELECTRICAL REQUIREMENTS.** The electrical requirements for the individual relay windings, spring terminal arrangements, and coil resistances will be found in figures 56 to 71 inclusive.

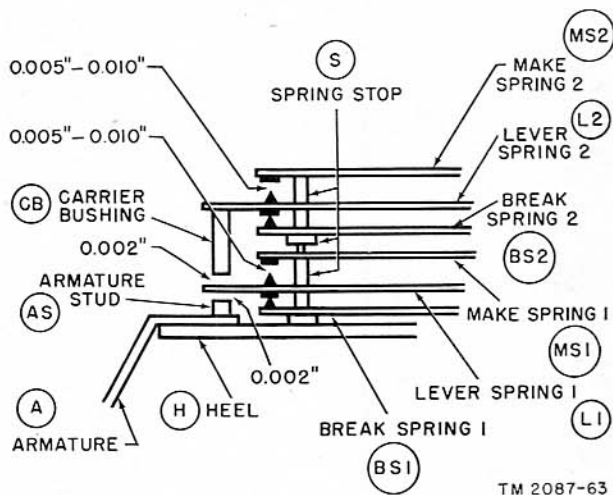
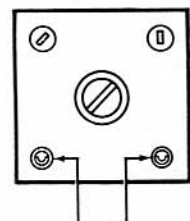
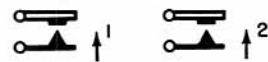

Figure 55. Multiple spring pile-up, normal position.



RELAY TERMINALS

1. MAKE CONTACT

2. MAKE CONTACT

COIL RESISTANCE - 500 OHMS

CURRENT FLOW IN AMPERES			
TEST		READJUST	
OPERATE	RELEASE	OPERATE	RELEASE
0.015	0.002	0.012	0.003

TM 2087-64

Figure 56. Winding and spring terminal arrangement of Kellogg 561-A line relays, terminal end view.



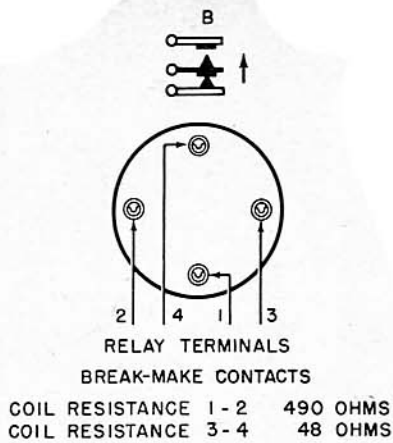

CURRENT FLOW IN AMPERES 24V				
TERMINALS	TEST		READJUST	
	OPERATE	RELEASE	OPERATE	RELEASE
3-4	0.022	0.003	0.020	0.004

TM 2087-65

Figure 57. Winding and spring terminal arrangement of Kellogg D-2001-T-BX cord circuit relay, terminal end view.

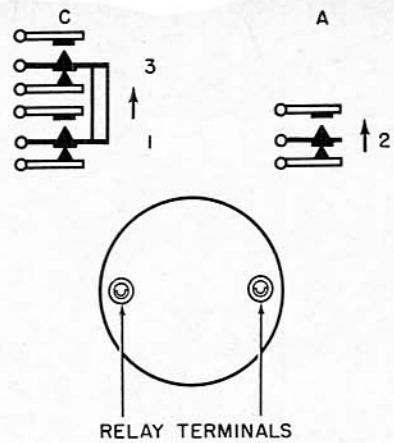

CURRENT FLOW IN AMPERES			
TEST		READJUST	
OPERATE	NON-OPERATE	OPERATE	NON-OPERATE
0.034		0.018	

TM 2087-67

Figure 59. Winding and spring terminal arrangement of Kellogg 2003-S-V trunk circuit relay, terminal end view.

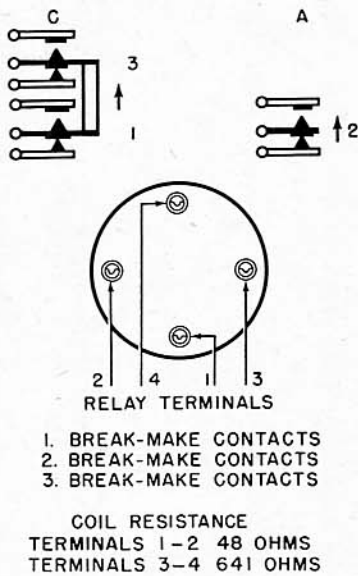

CURRENT FLOW IN AMPERES				
TERMINALS 3-4	TEST		READJUST	
	OPERATE	RELEASE	OPERATE	RELEASE
	0.029	0.003	0.027	

TM 2087-66

Figure 58. Winding and spring terminal arrangement of Kellogg 2003-T-CW cord circuit relay, terminal end view.

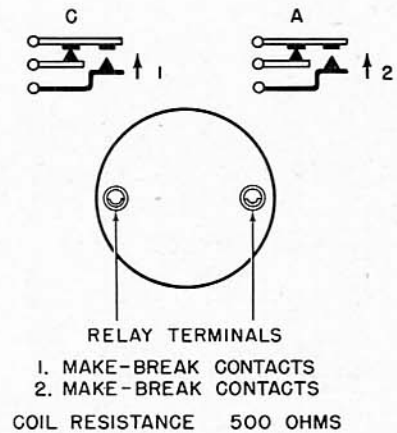

CURRENT FLOW IN AMPERES			
TEST		READJUST	
OPERATE	RELEASE	OPERATE	RELEASE
0.034		0.019	

TM 2087-68

Figure 60. Winding and spring terminal arrangement of Kellogg D-2007-S-AP dial relay, terminal end view.



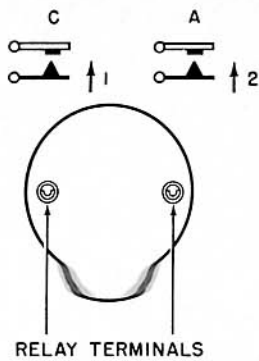

- RELAY TERMINALS
1. MAKE CONTACTS
  2. MAKE CONTACTS

2037SP COIL RESISTANCE 200 OHMS  
2037SGG COIL RESISTANCE 500 OHMS

RELAY	CURRENT FLOW IN AMPERES			
	TEST		READJUST	
	OPERATE	NON-OPERATE	OPERATE	NON-OPERATE
2037SP	0.028		0.016	
2037SGG	0.034	0.008	0.018	0.009

TM 2087-69

Figure 61. Winding and spring terminal arrangement of Kellogg D-2037-S-P and 2037-S-GG dial circuit and trunk circuit relays, terminal end view.

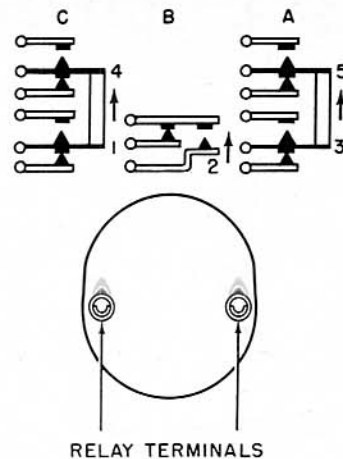

- RELAY TERMINALS
1. BREAK-MAKE CONTACTS
  2. MAKE-BREAK CONTACTS
  3. BREAK-MAKE CONTACTS
  4. BREAK-MAKE CONTACTS
  5. BREAK-MAKE CONTACTS

COIL RESISTANCE 500 OHMS

CURRENT FLOW IN AMPERES			
TEST		READJUST	
OPERATE		OPERATE	
0.034		0.027	

TM 2087-71

Figure 63. Winding and spring terminal arrangement of Kellogg 2046-S-V operator's circuit relay, terminal end view.

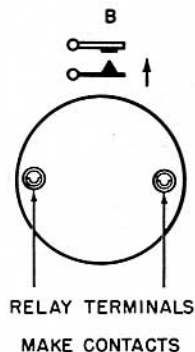

RELAY TERMINALS

MAKE CONTACTS

2043SEQ COIL RESISTANCE 1.5 OHMS  
2043SEB COIL RESISTANCE 4.5 OHMS

RELAY	CURRENT FLOW IN AMPERES				
	AFTER SOAK	TEST		READJUST	
		OPERATE	RELEASE	OPERATE	RELEASE
2043SEQ	1.5	0.079	0.C.	0.062	0.C.
2043SEB	1.5	0.078	0.C.	0.052	0.C.

TM 2087-70

Figure 62. Winding and spring terminal arrangement of Kellogg F-2043-S-EQ and F-2043-S-EB pilot and alarm relays, terminal end view.

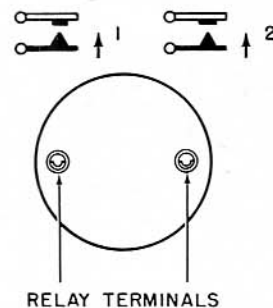

RELAY TERMINALS

1. MAKE CONTACT
2. MAKE CONTACT

COIL RESISTANCE 1,000 OHMS

CURRENT FLOW IN AMPERES			
TEST		READJUST	
OPERATE		OPERATE	
0.020		0.013	

TM 2087-72

Figure 64. Winding and spring terminal arrangement of Kellogg 2048-S-FY trunk relay, terminal end view.

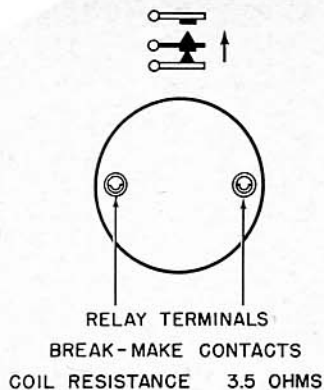

CURRENT FLOW IN AMPERES				
TEST			READJUST	
AFTER SOAK	OPERATE	RELEASE	OPERATE	RELEASE
1.500	0.037	0.0015	0.022	0.002

TM 2087-73

Figure 65. Winding and spring terminal arrangement of Kellogg 2102-S-HG pilot alarm relay, terminal end view.

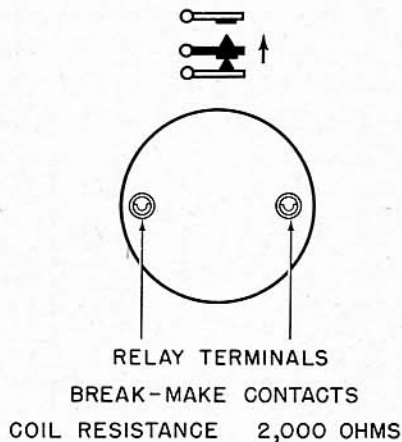

TEST ON 30-VOLT 20-CYCLE ac IN SERIES WITH 1 MF CAPACITOR.  
TEST WITH 30-VOLT 20-CYCLE ac IN SERIES WITH 1 MF CAPACITOR, HOLD CURRENT "ON".

TM 2087-74

Figure 66. Winding and spring terminal arrangement of Kellogg 2105-S-JD trunk circuit relay, terminal end view.

e. RELAY TABLES. Mechanical requirements for Kellogg relays are given in the table below.

Relay code No.	Spring tension (grams)	Armature travel (in.)	Residual pin air gap (in.)
561-A		0.020	
D-2001-T-BX		.010	0.002 min 0.004 max
2003-T-CW	15	.020	
2003-S-V	20	.020	
D-2007-S-AP	20	.020	0.003
2037-S-P	20	.020	0.015
2037-S-GG	20	.020	
F-2043-S-EQ	15	.015	
F-2043-S-EB	20	.020	
2046-S-V	20	.020	
2048-S-FY	20	.020	
2053-S-BN			
2105-S-JD	20	.015	

## 95. Audible Alarms

### a. NIGHT ALARM BELL.

- (1) *Cleaning parts and contacts.* Use the same procedures for cleaning the parts and contacts of the night alarm bell as are outlined for cleaning the parts and contacts of relays.
- (2) *Tightness of screws and locknuts.* Keep screws and locknuts sufficiently tight to maintain their adjusted positions. Gage by eye and feel. If a contact screw is loose, tighten the locknut securely.
- (3) *Possible troubles.* If the voltage is within normal limits but satisfactory operation is not obtained, it may be because of faulty connections, excessive or insufficient contact spring tension, improper contact separation, insufficient gap between the armature and the core, the armature and the core may be out of parallel, the clapper may be distorted, or the coil winding may be shorted or open. Check the coil for continuity; if perfect, the coil resistance will measure approximately 300 ohms.
- (4) *Failure to operate.*
  - (a) Insufficient separation between the core and the armature results in the armature striking the core too soon.

If the position of the armature is not satisfactory, adjust the armature stop screw or bend the armature near the fulcrum. It may also be necessary to reduce or increase the tension of the armature spring. This is done by turning the setscrew on the flange offset from the armature support frame.

- (b) Excessive armature travel may be checked by placing a screw driver lightly against the outside surface of the armature to move it nearer the core. If this improves the tone, reduce travel by moving the armature stop screw inward and resetting the contact spring tension.
- (c) See that there is a slight separation be-

tween the contact screw and the contact when the armature moves in.

(5) *Pitch of bell.*

- (a) The pitch may be varied by changing the tension of the contact spring. Decreasing tension will decrease the pitch and vice versa.
- (b) If the bell does not operate satisfactorily, it may be because the clapper is striking the edge of the movement cover. If the armature vibrates freely but the clapper does not strike the gong, adjust the clapper as required with long-nose pliers.

b. FUSE ALARM BUZZER. Check and service according to procedure given in *a* above for servicing the night alarm bell.

## Section IX. REFINISHING

### 96. General

This section outlines inspection procedures, general cleaning, and refinishing of apparatus. It includes only minor repairs; for specific procedures on reconditioning apparatus, see paragraphs 65 through 69.

### 97. Inspection

a. Examine apparatus for obvious mechanical defects as determined by visual inspection and feel. Make this examination without entirely dismounting or removing the part from the equipment except as found necessary in connection with the application of fungiproofing treatment.

b. Inspect for the following:

- (1) Dirt, rust, corrosion, and fungus.
- (2) Loose and missing apparatus.
- (3) Missing, cracked, broken, burred, chipped, worn, bent, and warped parts of apparatus.
- (4) Damage to finish.
- (5) Frayed cords and bent plugs.
- (6) Legibility of rubber stamping.
- (7) Discolored resistors and coils because of excessive current.
- (8) Flash-over paths on terminal boards, sockets, and insulation of terminals.
- (9) Proper fusing as designated on circuits or designation strips.

c. Minor defects such as slightly burred, chipped, worn, bent, and warped parts which do not interfere with the proper functioning of the apparatus are not considered objectionable and need not be repaired.

### 98. Cleaning

Remove dirt, rust, corrosion, and fungus from all equipment, except cords, plugs, and adjustable parts such as relays, with sandpaper or scratch brush and a clean, lint-free cloth. Cords should be reasonably free from discoloration. Clean all soiled cords by wiping or rubbing them with a cloth moistened with petroleum spirits. Do not apply wax to cords. Clean the external parts of adjustable apparatus, such as the outside of relay covers and caps and the terminals of jacks, switches, and relays, with a bristle brush and a clean cloth. Cleaning of other parts should be done when repairs or readjustments are made.

### 99. Replacement and Repair

a. GENERAL. In the removal and replacement of defective apparatus, be careful to avoid further damage to the adjacent equipment or to the part being replaced. Before attempting replacement or repair, make every effort to obtain the proper tools for the job. Secure screws and nuts snugly, but do not overtighten.

*b.* **BROKEN OR MUTILATED PARTS.** In general, replace broken or badly mutilated parts of apparatus when these parts are available.

## **100. Appearance**

*a.* **GENERAL.** Check all surfaces of wood, metal, rubber, and leather parts for the appearance and condition of the finish. From a protection and durability standpoint, the finish should show no decided wear and should not be chipped or otherwise damaged to expose bare wood or metal. Where the finish has been completely removed, worn extremely thin, or removed as a result of sanding or scratch brushing, retouch such surfaces if the bare spots are restricted to small areas. If the bare or damaged spots cover large areas, completely refinish the entire part. Slightly discolored, spotted, faded, or stained surfaces are per-

missible, provided the original finish is intact.

*b.* **FINISH PROCEDURES.** Retouch affected surfaces, after sanding or scratch brushing, to match the surrounding finish. Apply one coat of clear lacquer to parts having a bright finish, such as zinc- and nickel-plated surfaces, one coat of black lacquer to black surfaces, and one coat of matched color lacquer to other surfaces.

## **101. Alinement of Apparatus Mountings**

*a.* **JACKS.** See that all mounting plates, line jacks, and lamp jack mountings are alined. If not, loosen holding screws and aline as required.

*b.* **SWITCHES.** Line up all switches in the switch shelf so that the center line of the switch levers line up with the center line of their associated cords. Tighten all switches to switch mounting bars.

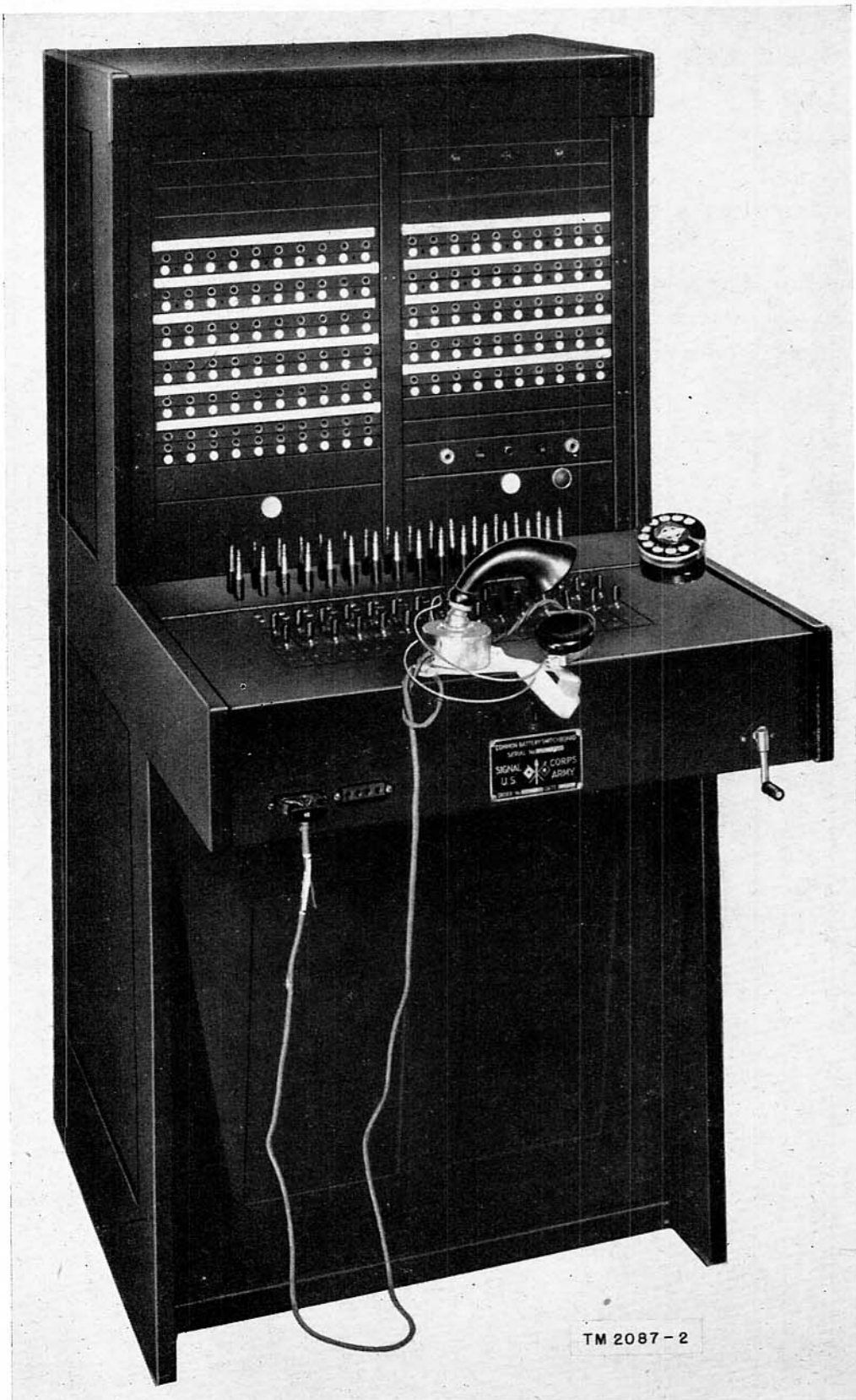

Figure 67. Switchboard SB-53( )/FTC (Stromberg-Carlson universal type 106).



## PART THREE

# SWITCHBOARD SB-53( )/FTC (Stromberg-Carlson universal type 106)

## CHAPTER 5

### DESCRIPTION AND DATA

#### 102. General

*a.* Switchboard SB-53( )/FTC (Stromberg-Carlson universal type 106) (figs. 67, 68, and 69) is a single-position, manually operated, cord-type universal switchboard designed for use at fixed installations for connecting locally associated common battery and magneto telephones as well as for originating and terminating calls to other switchboards.

*b.* This switchboard provides 110 lines, 100 for locally associated telephones and 10 for trunk lines. Fifteen talking connections can be made through the switchboard simultaneously.

*c.* Two operator's telephone sets are provided with each switchboard. A magneto ringing generator is built into the switchboard. The switchboard is also designed for use with a separate power ringing generator. Such a generator is not furnished with the board; if one is used it is supplied by the using organization.

*d.* Operation of the switchboard requires a 24-volt d-c power supply (generally a storage battery) which must be supplied by the using organization. The using organization also furnishes an operator's chair.

#### 103. Weight and Dimensions

*a.* Data given below is for the switchboard unpacked and ready for installation.

Unit	Height (in.)	Width (in.)	Depth (in.)	Weight (lb.)	Volume (cu. ft.)
Switchboard SB-53 ( )/FTC (Stromberg-Carlson universal type 106)---	51¼	25½	25	525	26.2

*b.* Furnished with each switchboard is a tool roll, a set of drawings, a carton of maintenance parts, and a carton of unassembled parts. Two

operator's telephone sets are also furnished with each switchboard.

#### 104. Packaging Data for Export Shipment

Refer to paragraph 6 for instructions for packaging Switchboard SB-53( )/FTC for export shipment. Instructions given there are applicable to both the Kellogg type Switchboard SB-53( )/FTC and Stromberg-Carlson universal type 106.

#### 105. Description of Switchboard Unit (fig. 68)

All parts of Switchboard SB-53( )/FTC are contained or mounted within the switchboard cabinet. The two operator's telephone sets are supplied separately.

##### *a.* FRONT OF SWITCHBOARD.

- (1) Each of the two panels on the upright section of the switchboard contains five designation strips and a like number of line jack and line lamp strips. There are 10 line jacks mounted on each line jack strip and 10 line lamps are mounted on each line lamp strip.
- (2) At the top of the right-hand panel are mounted three plunger-type switches. One of these, marked GEN, is for either a power generator or the magneto ringer. A second, marked NA, is a control in the night alarm circuit, and the third, marked BAT, is in the battery cut-off circuit.
- (3) Below the left-hand group of line jack and line lamp strips are three additional strips. The upper one of these strips contains 10 trunk-dial jacks, the middle one 10 trunk jacks, and the lower one 10 trunk line lamps.
- (4) Two jacks for testing cord circuits, either for magneto or common battery operation, are located in the lower part

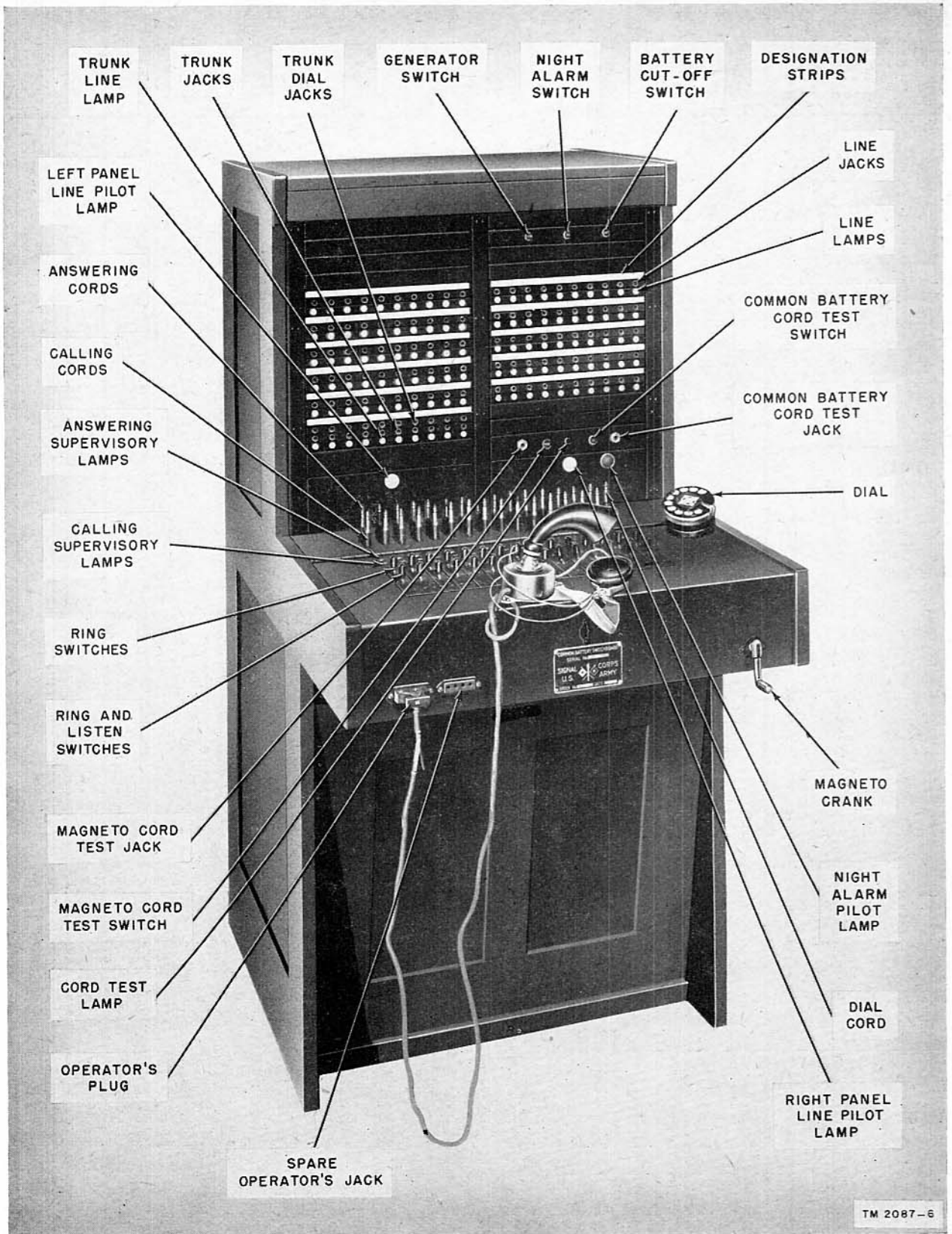

Figure 68. Switchboard SB-53( )/FTC (Stromberg-Carlson universal type 106), front view.

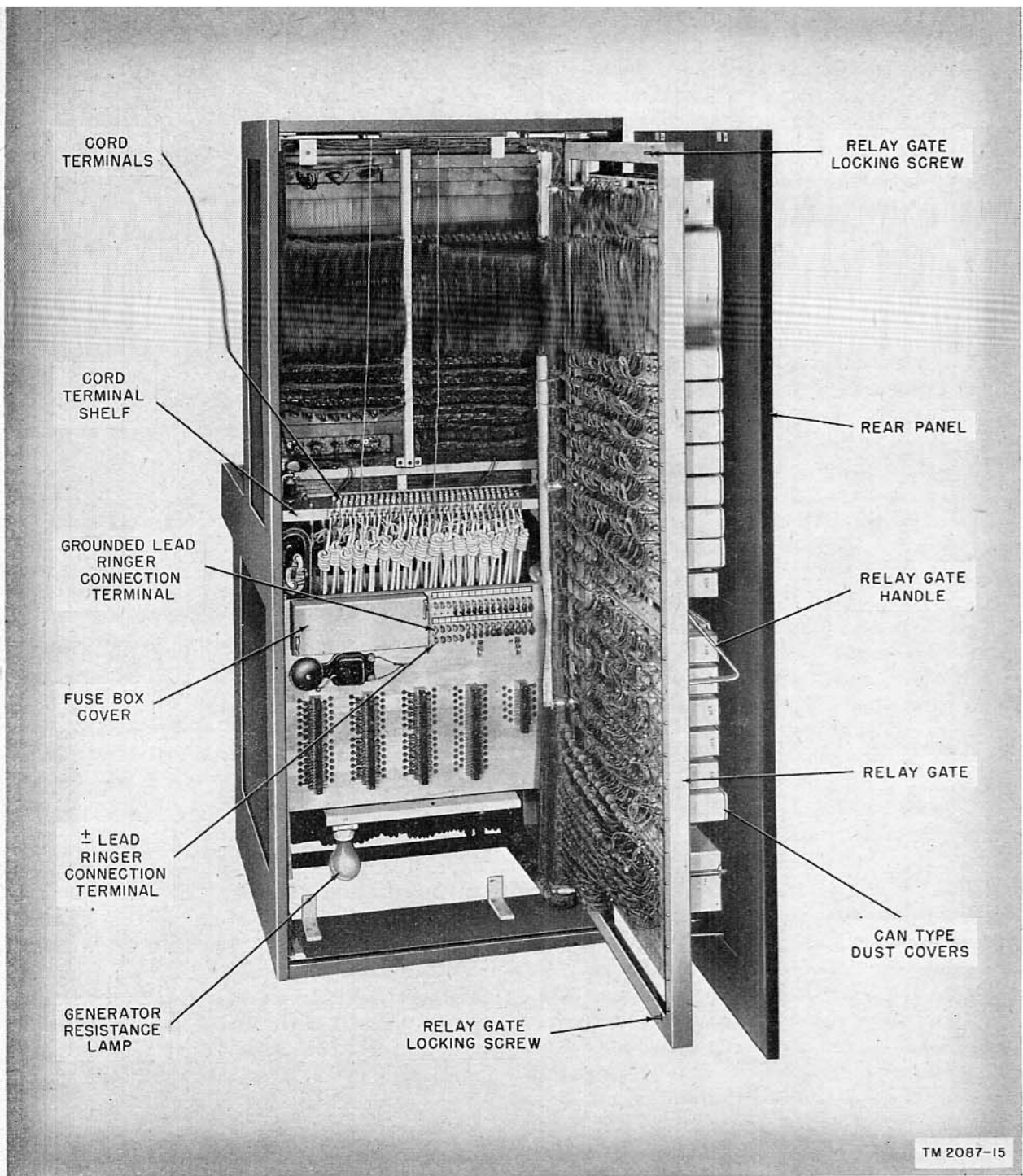

Figure 69. Switchboard SB-53( )/FTC (Stromberg-Carlson universal type 106), rear view.

of the right-hand panel. Each jack has an associated plunger switch marked MAG and CE, respectively, for magneto or common battery operation testing. A cord test lamp for both circuits is located between the switches. A line pilot lamp for each group of 50 lines is located at the bottom of each panel and a red night

alarm pilot lamp is mounted at the bottom of the right-hand panel.

- (5) At the rear of the switch shelf are located a row of answering cords and a row of calling cords. There are 15 cords in each row. A single cord to the right of the answering and calling cord pairs is the dial cord which provides a means of com-



pleting a dial circuit for outgoing trunk calls.

- (6) Alined with the cord pairs and also on the hinged portion of the shelf are two rows of supervisory lamps, 15 in each row. The lamps in the rear row are the answering supervisory lamps. The lamps in the front row are the calling supervisory lamps. All are arranged to work in coordination with the respective cords associated with them.
- (7) Fifteen ring-back and ring-listen switches are mounted as pairs in a row of plates alined with the corresponding cords and supervisory lamps. A dial is mounted on the right side of the switch shelf. Two plug jacks for the operator's telephone sets are located on the left front edge of the shelf, and on the right front edge of the shelf the magneto ringer crankshaft is located. By unlocking the shelf panel, access is gained to the switch and lamp wiring. Once the shelf panel is raised, it may be locked in raised position with a locking brace.
- (8) To gain access to the cords and cord weights, remove the front panel below the switch shelf.

*b. REAR OF SWITCHBOARD.* By removing the rear panel of the switchboard (figs. 69 and 72), access is gained to a full length swinging relay gate. Mounted on this gate are the relays for the cord and trunk circuits, the short and long lines relays, the relays for the operator's and the alarm circuits, resistors, and associated coils and capacitors. These are covered with can-type dust covers, some of which are retained in place by wingnuts, threaded on studs attached to mountings on the relay gate, and others of which are held in place by means of slide clips. Release of screws at the left top and bottom of the gate allows access to the internal wiring, the magneto generator, the night alarm bell, cords, fuse, and terminal boards.

*c. OPERATOR'S TELEPHONE SETS.* The operator's telephone sets (fig. 70), two of which are supplied with this model of Switchboard SB-53( )/FTC, consist of a breastplate transmitter and a head band receiver and cord set terminated in a 4-prong plug.

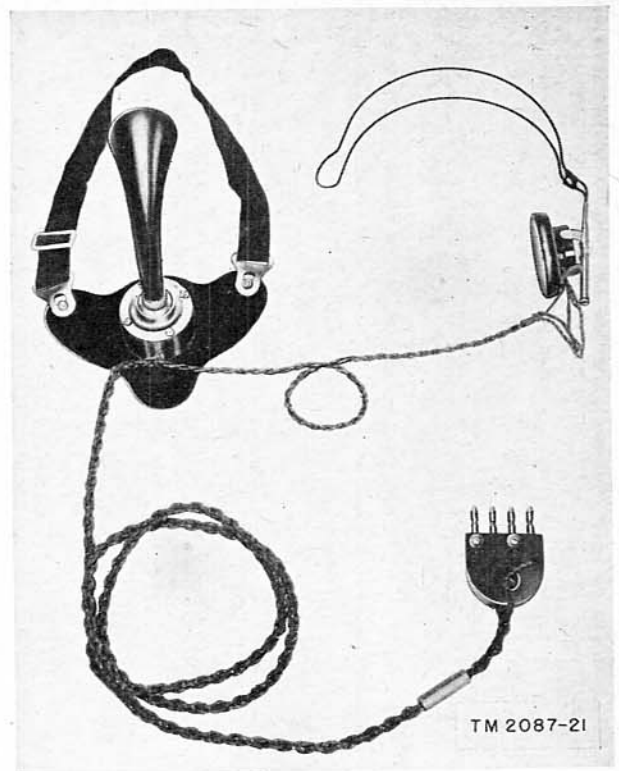

Figure 70. Operator's telephone set supplied with Switchboard SB-53( )/FTC (Stromberg-Carlson universal type 106).

## 106. Application of Equipment

*a.* Switchboard SB-53( )/FTC is generally used in either a small central office as a branch exchange at a fixed indoor location or as a small main exchange. Facilities are provided for 100 local lines and 10 trunk lines. The 10 trunk lines provide trunking facilities for the 100 local lines to any magneto, common battery, or dial exchange. Refer to figure 5 for possible connections with Switchboard SB-53( )/FTC.

*b.* Switchboard SB-53( )/FTC is equipped with the following features: direct dialing of trunk circuits, supervisory and pilot lamps, an operator's telephone circuit, a night alarm circuit, a cord test circuit, and a magneto generator ringing circuit.

*c.* The Stromberg-Carlson universal type 106 switchboard provides for the installation of 20 longer than normal lines. The long lines are numbered from 1 through 20, the short lines from 21 through 100.

## CHAPTER 6

### OPERATING INSTRUCTIONS

#### Section I. SERVICE UPON RECEIPT OF EQUIPMENT

##### 107. General

Refer to paragraphs 9 through 12 for instructions on steps to follow when Switchboard SB-53( )/FTC is received. Paragraph 108 gives specific instructions for the installation of the Stromberg-Carlson type of Switchboard SB-53( )/FTC.

##### 108. Installation Procedure

- a. Remove the rear panel of the switchboard and open the relay gate (fig. 69).
- b. Terminal boards (fig. 71) within the switch-

board are marked with line numbers of the first and last lines that these boards are to carry. The numbering is from top to bottom. A short terminal board, first from the right, has terminals for 10 trunk lines. This board is marked TRKS with 1 at the top and 10 at the bottom. The second terminal board from the right carries lines 1 through 25; the third from the right, lines 26 through 50; the fourth, lines 51 through 75; and the fifth, lines 76 through 100.

- c. Identify each pair of wires that make up a line. Fan out the pairs along the bottom of the fanning board behind the terminal boards. Bring

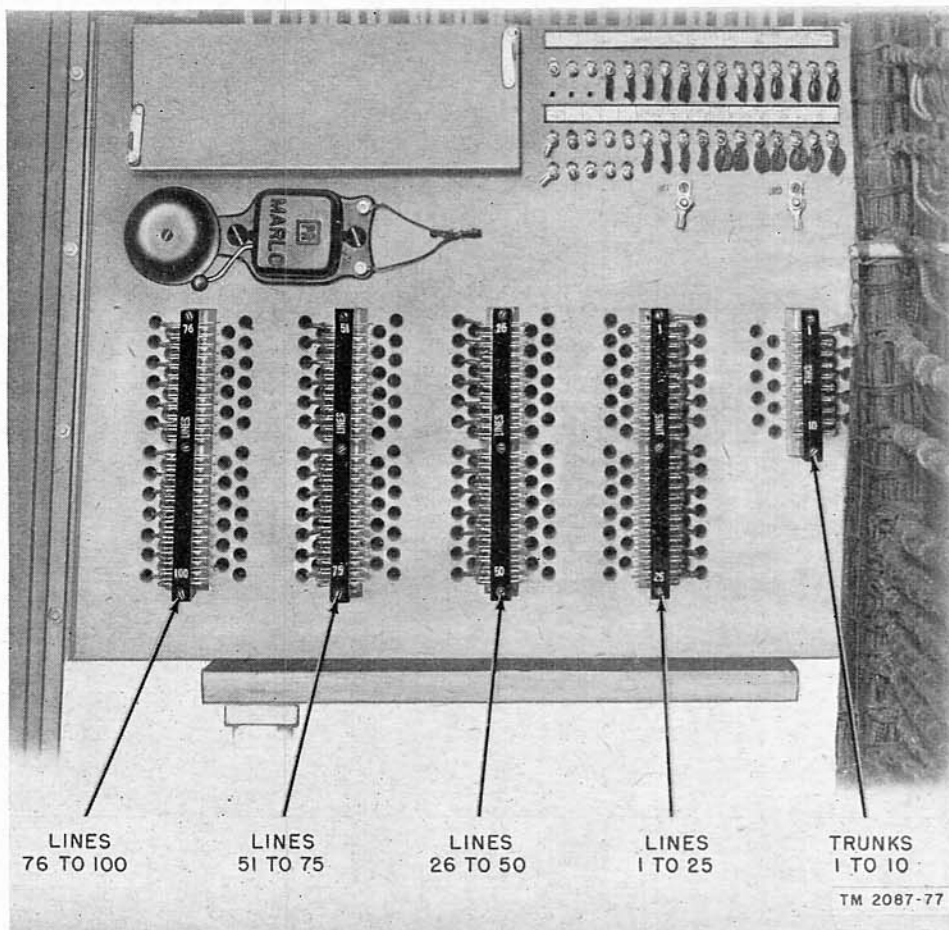

Figure 71. Fanning and terminal boards.



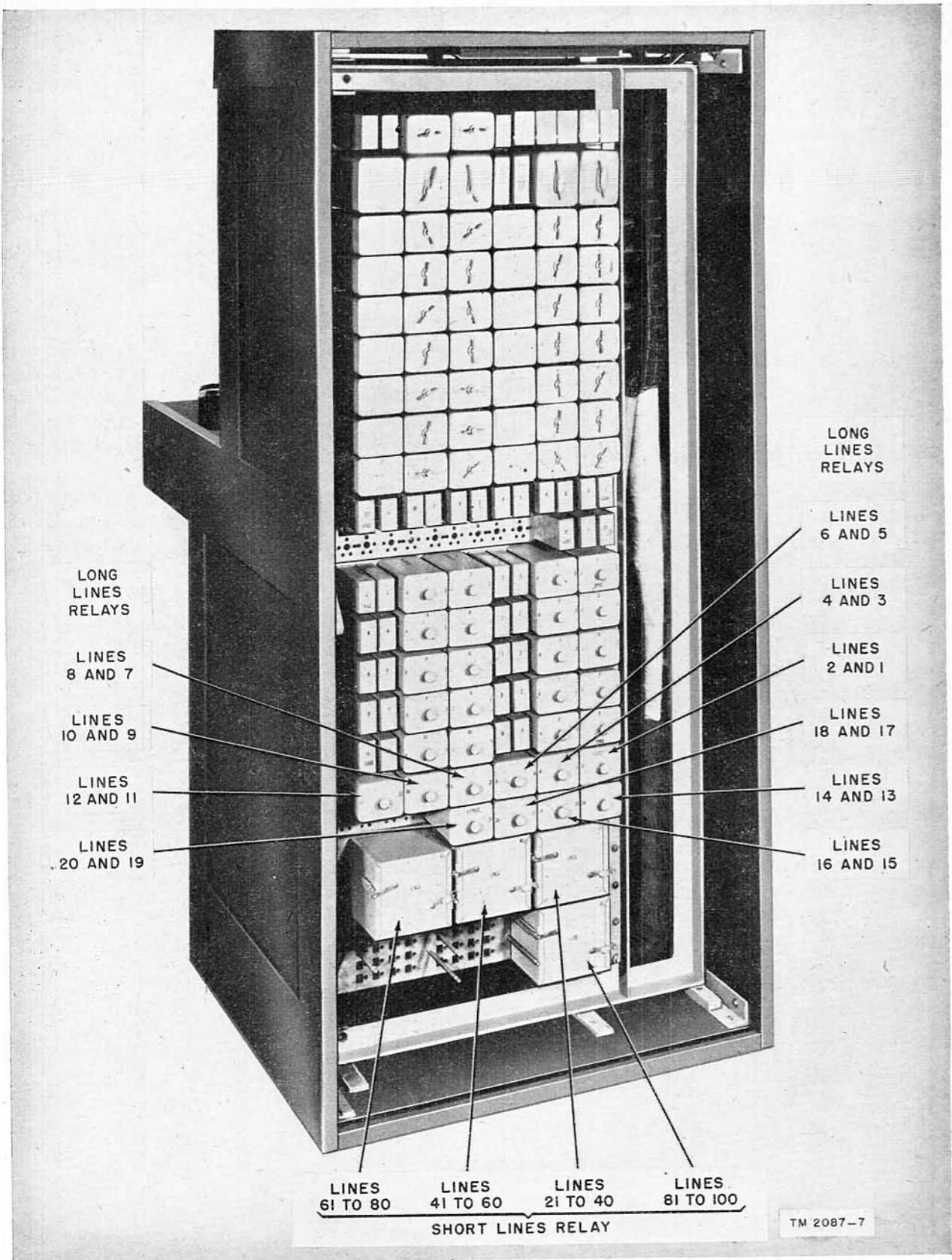

Figure 72. Switchboard SB-53( )/FTC (Stromberg-Carlson universal type 106) showing locations of long and short lines relays.

the first wire pair for line 1 through the top hole to the left of the first terminal board, and attach the wires to the top set of terminals by winding each wire around one terminal of the pair. Lead the second pair for line 2 through the hole beneath, and connect this pair in the same manner to the second pair of terminals. Continue in this way until all 25 pairs have been connected; then start with line 26 at the top of the second line terminal board, etc.

d. Attach the 10 trunk lines in the same way to the trunk line terminal board at the right.

e. After all wire pairs have been attached, arrange them neatly behind the fanning board and lace them tightly into cables in the conventional manner, using waxed lacing cord. Unwind each lead from its terminal and solder as directed in paragraph 12.

f. Wire-type fuses are installed in the switchboard at the factory but they must be checked for opens before the switchboard is put into use. Remove the cover from the fuse box located at the top left-hand side on connecting rack (fig. 69) and compare the fusing shown in the wiring diagram supplied with the equipment. Spare fuses are packed in the carton of replacement parts.

g. Connect the 24-volt, d-c power supply to the battery terminals on the connecting rack (fig. 69) with polarity as shown.

h. Check that the lamps and lamp caps have been installed at the factory.

i. Unpack the hand crank from the unassembled parts carton and install it on the end of the magneto generator shaft which protrudes from the right front edge of the switch shelf (fig. 68).

j. If a power ringing generator is to be used, connect the leads for the generator to the terminals at the right of the fuse box, and connect the grounded wire to the upper terminal. The proper terminals are marked POWER GEN (fig. 69) on the identification strip above the terminals.

k. The line relays of the Stromberg-Carlson type of switchboard may be wired for operation with common battery or magneto telephones. Refer to figure 72 for locations of the long lines and short lines relays and to figures 73 and 74 to aid in rewiring the relays if rewiring becomes necessary.

l. If it becomes necessary to rewire a long lines relay (lines 1 through 20) for magneto operation, refer to figure 73 and make the following changes: Remove the green wire from spring terminal 1;

remove the two red wires from coil terminal 3 and connect the green wire at that point; untwist the red and white wire which is wrapped around the cable form and attach it to coil terminal 2.

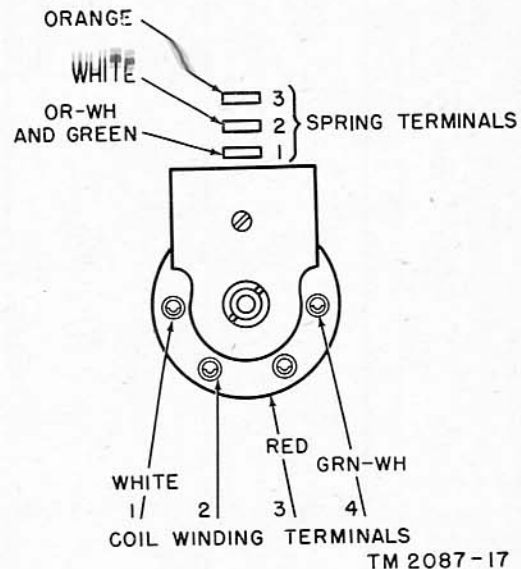

Figure 73. Switchboard SB-53( )/FTC (Stromberg-Carlson universal type 106), long lines relay wiring diagram.

m. To rewire a short lines relay (lines 21 through 100), refer to figure 74 and make the following changes in wiring: Remove the green wire from terminal 3 and detach the tinned strap from terminal 1. This is a common lead. Be careful not to break the continuity of the other relays. Unwrap the red and white wire wound around the cable form and attach it to terminal 1.

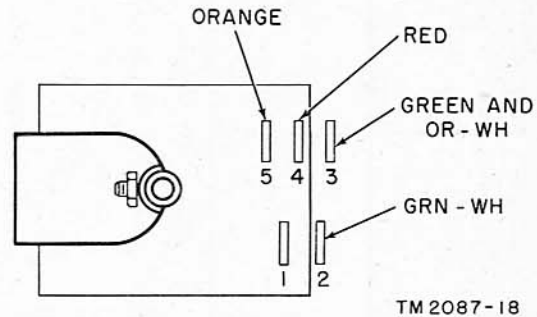
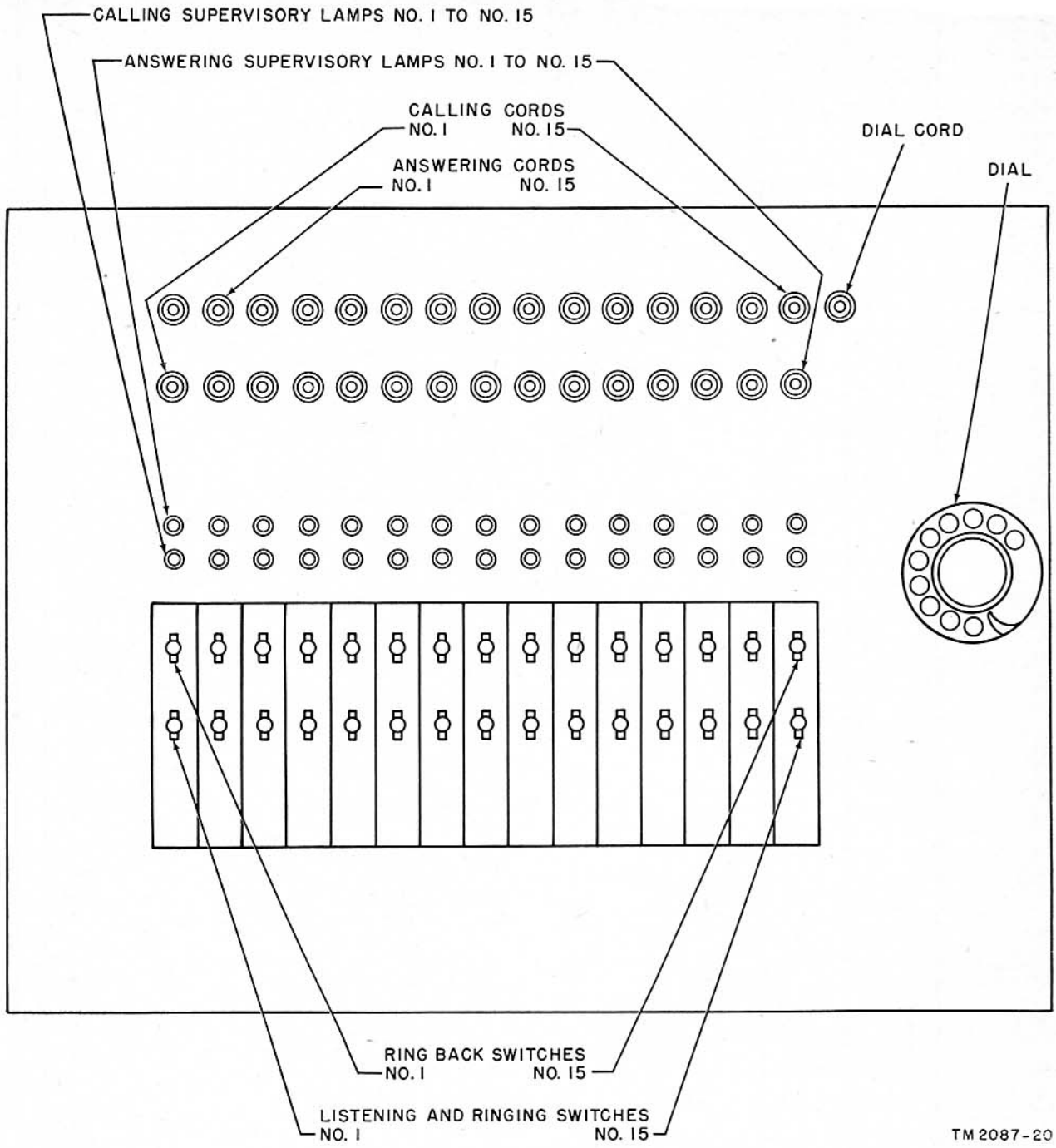

Figure 74. Switchboard SB-53( )/FTC (Stromberg-Carlson universal type 106), short lines relay wiring diagram.

n. To rewire a long lines relay from magneto operation to common battery operation, reverse the procedure outlined in l above.

o. To rewire a short lines relay from magneto to common battery operation, reverse the procedure outlined in m above.



TM 2087-20

Figure 75. Switchboard SB-53( )/FTC, (Stromberg-Carlson universal type 106), top view of switch shelf, showing arrangement of cords, lamps, and switches.

## Section II. CONTROLS

*Note.* This section describes, locates, illustrates, and furnishes the operator sufficient information pertaining to the various switches provided for the proper operation of the switchboard.

### 109. Cord Circuit Switches (fig. 75)

*a.* LISTENING AND RINGING SWITCHES. The row of 15 two-position, one-position-locking, and lever-type listening and ringing switches is located at the front of the switch shelf, each switch aligned with its particular cord pair. The switch is operated to its rear position to listen in a particular cord circuit and is moved to its forward position to ring a called line.

*b.* RING-BACK SWITCHES. The 15 switches in the rear row are one-position, nonlocking, lever-type switches used to ring back a calling line when moved to the rear position.

### 110. Generator Switch

The generator switch marked GEN is a plunger-type, two-position switch mounted at the top of the right-hand panel. When the switch is locked in, the ringing current leads are connected to the magneto ringer; when pulled out, the ringing circuit is connected to a power ringer.

### 111. Night Alarm Switch

The night alarm switch marked NA is similar to the generator switch. When the switch is locked in, the night alarm circuit is connected and the night alarm bell will ring; when the switch is pulled out, the bell is silenced and the circuit is disconnected.

### 112. Battery Cut-off Switch

The battery cut-off switch marked BAT, when locked in, connects battery to the switchboard; when pulled out, it disconnects the switchboard power. This switch is used only when the board is shut down for a considerable period.

### 113. Cord Test Jacks, Switch, and Test Lamp

*a.* GENERAL. The cord test jacks, switch, and test lamp are located at the bottom of the front right-hand panel (fig. 68). The right-hand jack is used to test the cord circuits for common battery operation; the left-hand jack is used to test for magneto operation. Each test circuit is equipped with an independent test switch.

*b.* COMMON BATTERY OPERATION. When a cord plug is inserted into the test jack, the supervisory lamp associated with that cord should light. When the test switch is operated to represent an answered condition, the lamp should go out. To test the cord for its ringing condition, operate the ringing switches. The cord test lamp should light to indicating ringing.

*c.* MAGNETO OPERATION. A cord plug inserted into the magneto test jack establishes a ringing circuit which is completed when the test switch is operated. This represents ringing off at a magneto telephone and causes the associated supervisory lamp to light. Operation of the listening switch extinguishes the lamp. The ringing condition of the cord is tested by operating the ringing switches to light the cord test lamp.

*Note.* Refer to paragraphs 21 through 32 for information covering preliminary tests and operation of Switchboard SB-53( )/FTC under usual and unusual conditions and for an equipment performance checklist.



## CHAPTER 7

### MAINTENANCE INSTRUCTIONS

#### Section I. SPECIAL ORGANIZATIONAL TOOLS AND EQUIPMENT

##### 114. Materials Required

Common materials required for organizational PM (preventive maintenance) procedures for Switchboard SB-53( )/FTC are listed in paragraph 33. These materials may be requisitioned through usual Department of the Army supply channels by their respective stock numbers.

##### 115. Tools Required

Tools needed for organizational maintenance of the switchboard are supplied with the switchboard. They are arranged in a canvas tool roll (fig. 76) which contains the following tools:

- No. 44 Screw driver.
- No. 45 Screw driver.
- No. 7 Spring bender.
- No. 2 Socket wrench.
- No. 21 Screw driver.
- No. 36 Spring bender.
- No. 268 Spring bender.
- No. 319 Fuse pliers.
- No. 553 Lamp extractor.
- No. 42 Screw driver.
- No. 24 Socket wrench and screw driver.
- No. 61 Burnisher and sheath.

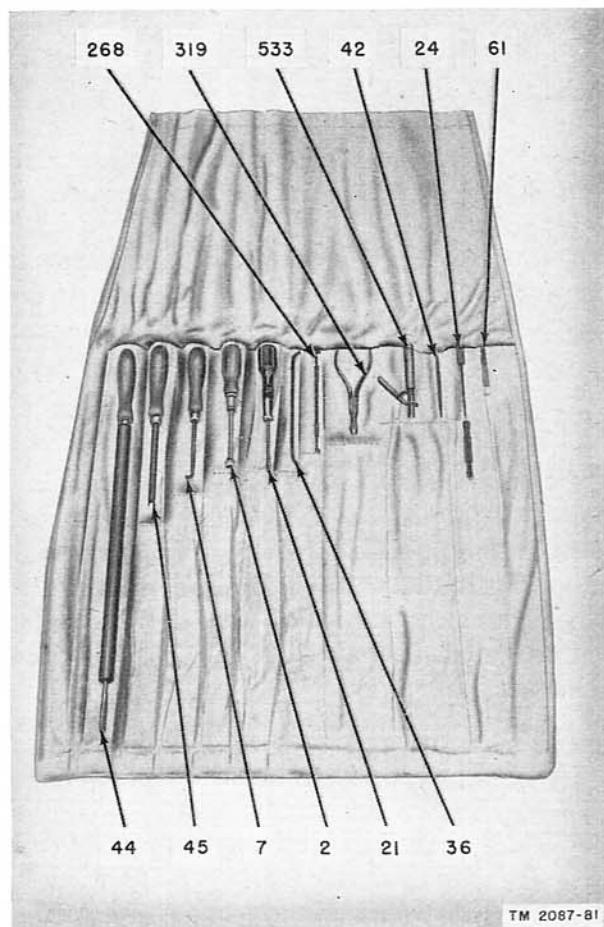

Figure 76. Tools supplied with Stromberg-Carlson universal type 106 switchboard.

#### Section II. WEATHERPROOFING AND PREVENTIVE MAINTENANCE SERVICES

##### 116. Weatherproofing

Because Switchboard SB-53( )/FTC is designed for indoor use at protected locations, it is not weatherproofed. However, if the occasion arises for its use in locations and temperatures which dictate the need for weatherproofing, instructions for weatherproofing treatment are given in paragraphs 35 through 38.

##### 117. Preventive Maintenance Services

General information on PM is given in paragraphs 40 through 44 of this manual. An applicable PM checklist is contained in paragraph 43. Trouble location methods are covered in paragraphs 70 through 72.

*Note.* Refer to paragraphs 30 and 44 and to chapter 4 of part three of this manual for information covering trouble shooting in connection with the operation of Switchboard SB-53( )/FTC.



## CHAPTER 8

### TECHNICAL SERVICES—FIELD AND DEPOT MAINTENANCE INSTRUCTIONS

*Note.* Paragraph 45 explains the scope and application of this chapter, and paragraph 46 lists references which will aid in the testing, repairing, and rebuilding of Switchboard SB-53( )/FTC.

#### Section I. THEORY OF OPERATION

##### 118. Universal Line Circuits

*a. GENERAL.* The line relay has an operate winding and a hold winding. The operate winding alone, connected to battery and ground through the line loop, is used for common battery operation. The two windings are used separately for magneto operation. The operate winding, connected directly to the line loop, operates the relay from ringing current and the hold winding holds the relay operated until the call is answered.

*b. CONNECTED FOR COMMON BATTERY OPERATION* (fig. 77). When a telephone receiver is lifted, the hookswitch closes the loop circuit. This energizes the operating winding of the line relay. The line relay functions and closes a contact which completes a circuit to light the line lamp. This signals the operator to answer by inserting the plug of the answering cord into the line jack. This opens the inside jack contacts to disconnect ground and

battery from the line. The line relay then releases and opens the circuit to extinguish the lamp.

*c. CONNECTED FOR MAGNETO OPERATION* (fig. 78). Cranking the magneto generator of a telephone causes ringing current to be transmitted over the line to operate the line relay. When the line relay operates, a contact completes a circuit to ground to energize the holding coil winding. This action lights the line lamp and holds is lighted until the circuit is broken. This signals the operator to answer. Circuit operation is then the same as is described in *b* above.

##### 119. Universal Trunk Circuit (figs. 79 and 80)

*a. OUTGOING CALLS.*

(1) *To common battery exchange.* Insertion of a cord circuit plug in a trunk line jack causes a make contact of the line jack to

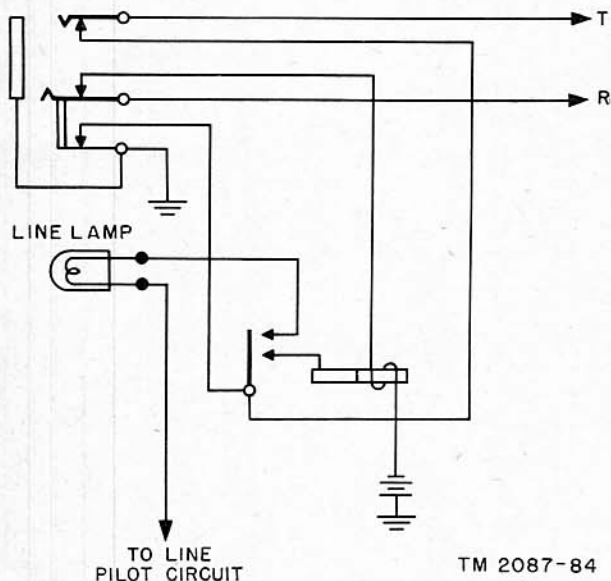

Figure 77. Universal line circuit connected for common battery operation, schematic.

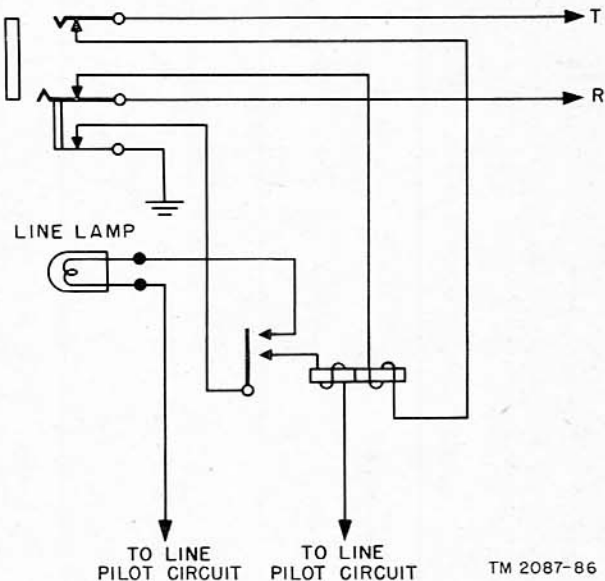

Figure 78. Universal line circuit connected for magneto operation, schematic.

complete the circuit to ground for the operation of relay 2. A make contact of relay 2 completes the trunk loop through coil 4 to signal the distant operator.

(2) *To magneto exchange.* The trunk circuit to a magneto exchange functions as described for the common battery exchange except that coil 4 is disconnected and the operator must ring to signal the distant exchange.

(3) *To dial exchange.* To call a dial exchange, a calling cord plug is inserted into a trunk line jack and the dial cord plug into the trunk dial jack. Insertion of the dial cord plug opens the dial jack break contact. This disconnects the trunk equipment and connects the dial directly to the trunk line. Operation of the dial transmits pulses to the called office through the dial jack. Immediately after dialing, the dial cord plug is removed.

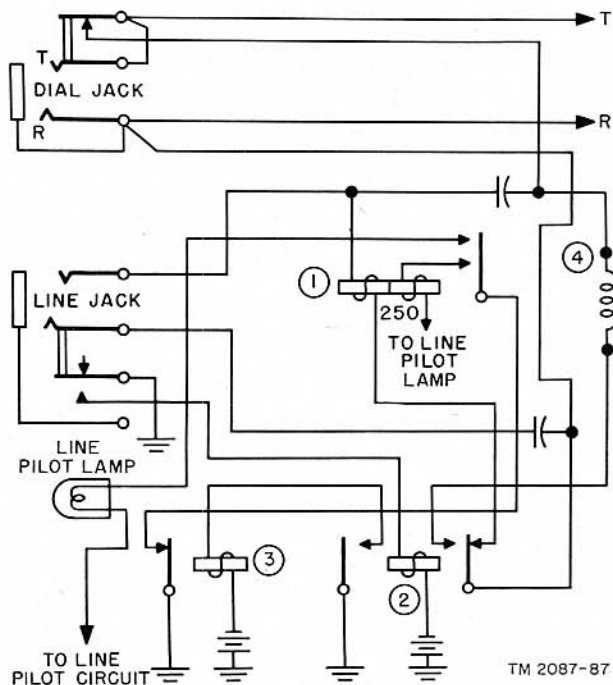

Figure 79. Universal trunk circuit connected for common battery operation, schematic.

*b. INCOMING CALLS.* On all incoming calls ringing current operates the a-c relay 1, which at a make contact completes a holding circuit for itself through its 250-ohm winding. The path of the holding circuit is from battery of the line pilot circuit through the 250-ohm winding, make contact of relay 1, and through break contact of relay 3 to

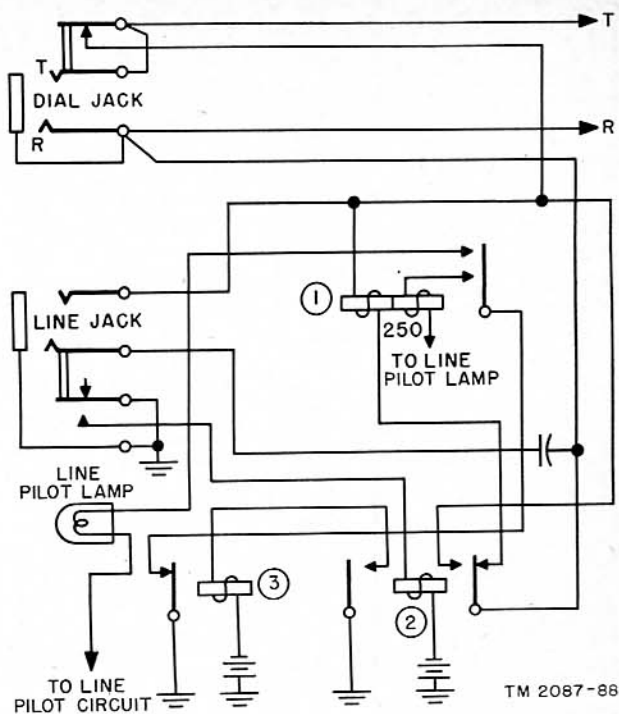

Figure 80. Universal trunk circuit connected for magneto operation, schematic.

ground. A make contact of relay 1 completes a circuit to light the line lamp. The path of this circuit is from battery, through the line pilot circuit, line lamp, relay 1 make contact, and relay 3 break contact to ground. The line lamp signals the operator to insert an answering cord plug in the line jack. This causes a jack spring to make contact and complete the circuit to ground for the operation of relay 2. A make contact of relay 2 completes the circuit to ground for the operation of relay 3. A break contact of relay 3 opens the ground circuit for the line lamp, which is extinguished, and also opens the holding circuit of relay 1 which releases. A make contact of relay 2 connects coil 4 (fig. 79) across the trunk to complete the trunk loop for the calling office and indicate an answered condition.

## 120. Universal Cord Circuit (fig. 81)

*a. COMMON BATTERY TO COMMON BATTERY CONNECTIONS.*

(1) The answering cord plug is inserted into the line jack of the calling telephone or trunk and the listening switch is moved to the operated position. Ground on the sleeve of the jack through the sleeve connection of the cord completes the circuit

through the 500-ohm winding of relay 1, which operates and closes contacts to complete the circuit for operating relay 3 through the calling line loop. At a make contact of relay 1, ground from the 75-ohm winding of relay 1 is connected through the 1-2 repeating coil winding, the ring-back switch contacts, and the tip of the plug to the tip wire of the calling line.

- (2) At another make contact of relay 1, battery, from the 75-ohm winding of relay 3, is connected through the 3-4 repeating coil winding, the ring-back switch contact, and the ring of the plug to the ring wire of the calling line. At another make contact of relay 1, the answering cord supervisory lamp is connected to a partially completed circuit through the supervisory pilot relay to ground. The ground circuit is opened at a break contact of operated relay 3 so that the supervisory lamp does not light.
- (3) After moving the listening switch to the operated position, the operator obtains the called numbers and then inserts the calling cord plug into the jack of the called telephone. Ground on the sleeve of the called telephone line jack causes the operation of relay 2 and the connection of talking battery to the called line, in the same manner as described above for relay 1. Since relay 4 does not operate because the called line loop is open, ground at the break contact of relay 4 completes the circuit to light the calling cord supervisory lamp. The operator then moves the calling cord ring switch to ring the bell of the called telephone. When the called telephone is answered, the circuit is completed for the operation of relay 4, which opens the circuit of the calling cord supervisory lamp at its break contact, causing it to be extinguished. The operator then returns the listening switch to normal for supervision.
- (4) To recall the operator, the local telephone receiver is replaced on the hookswitch, then removed to signal the operator that additional service is required. To terminate a call, the local telephone receiver is replaced on the hookswitch.

This opens the line loop circuit through the 75-ohm winding of relay 3 for the calling telephone and relay 4 for the called telephone. Relay 3, on releasing, closes a break contact which completes the circuit to light the cord supervisory lamp to signal the operator, so that the operator may establish, by monitoring, that the call is terminated and then remove the cord plugs from the line jacks, restoring the relays to normal.

b. MAGNETO TO MAGNETO CONNECTIONS.

- (1) The answering cord plug is inserted into the line jack of the calling telephone or trunk and the listening switch is moved to the operated position. The sleeve of the line jack of a magneto telephone is not grounded and relay 1 does not operate. After being given the called number, the operator inserts the calling cord plug into the line jack of the called telephone. Relay 2 is also inoperative because the sleeve of the line jack of a magneto telephone is not grounded. The listening switch is then moved to ring the bell of the called telephone. When the called telephone has been answered, the operator returns the listening switch to normal.
- (2) To recall the operator and to terminate a call, the telephone magneto is cranked to generate ringing current which passes through the 620-ohm winding in series with the 2,200-ohm, noninductive winding of relay 3 for the calling telephone, and relay 4 for the called telephone. The ringing current causes only initial operation of these relays to complete the holding circuit through their 75-ohm and 175-ohm windings in series. The holding circuit for relay 3 is completed through the supervisory pilot circuit while the holding circuit for relay 4 is completed directly to ground. The path of the holding circuit of relay 3 is from battery through the 75-ohm winding, a break contact of relay 1, a break spring contact of the listening switch, the 175-ohm winding of relay 3, a make contact of relay 3, and through the supervisory pilot circuit to ground.
- (3) The path of the supervisory lamp circuit for the answering cord is from battery

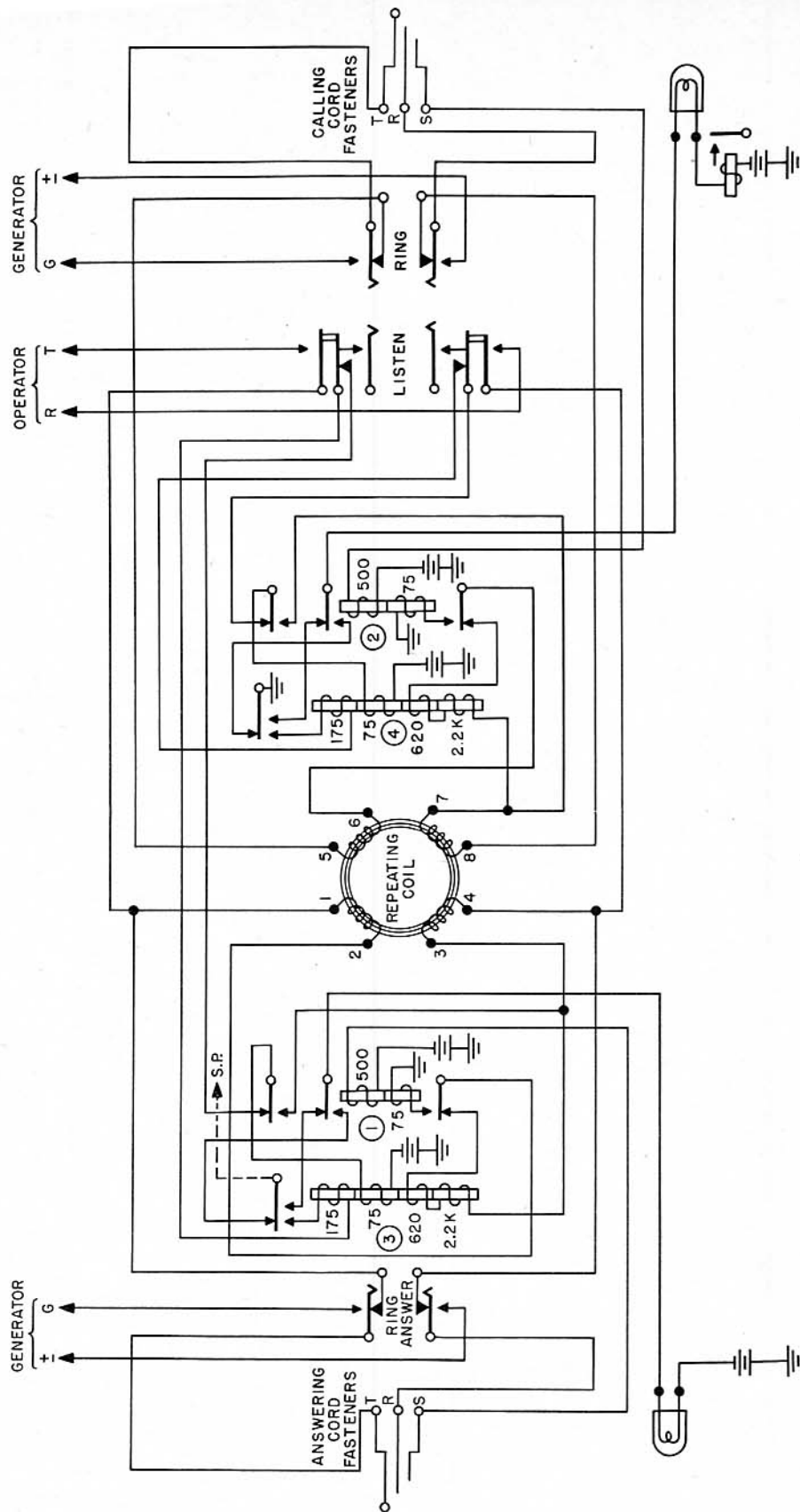

TM 2087-89

Figure 81. Universal cord circuit, schematic.

through the supervisory lamp, a break contact of relay 1, a make contact of relay 3, and through the supervisory pilot circuit to ground. The holding circuit of relay 4 is from battery through the 75-ohm winding, a break contact of relay 2, a closed break spring contact of the listening switch, the 175-ohm winding, and a make contact of relay 4 directly to ground.

- (4) The path of the supervisory lamp circuit for the calling cord is from battery through a 1.7-ohm relay winding, the supervisory lamp, a break contact of relay 2, and a make contact of relay 4 directly to ground. A supervisory lamp remains lighted until the holding circuit is opened by the operation of the listening switch when the operator determines whether another call is being originated or whether the call is terminated. If the call is terminated, the operator withdraws the cord plugs from the line jacks and the relays restore to normal.

*c.* COMMON BATTERY TO MAGNETO CONNECTIONS.

Answering the call is described in *a* above, and establishing the connection to the called telephone is described in *b* above.

*d.* MAGNETO TO COMMON BATTERY CONNECTIONS.

Answering the call is described in *b* above, and establishing the connection to the called telephone is described in *a* above.

### 121. Operator's Telephone Circuit (fig. 82)

The switchboard is equipped with two jacks wired in parallel to permit two operator's telephone sets to be connected to the operator's telephone circuit. This allows an experienced operator to train or supervise another. Inserting an operator's telephone set plug in either jack completes the transmitter circuit. Battery is connected through the 100-ohm winding of relay 2 to one side of the transmitter. Ground is connected through the 100-ohm impedance coil and the induction coil primary winding to the other side of the transmitter. Inserting an operator's telephone set plug in either jack also completes the circuit for the operation of relay 2 which at make contacts connects the operator's circuit to the listening switches, and connects the receiver into an antiside tone circuit across a part of the secondary winding of the induction coil and a noninductive resistor.

By operating the listening switch of a cord circuit, the operator's telephone circuit is connected for talking and listening.

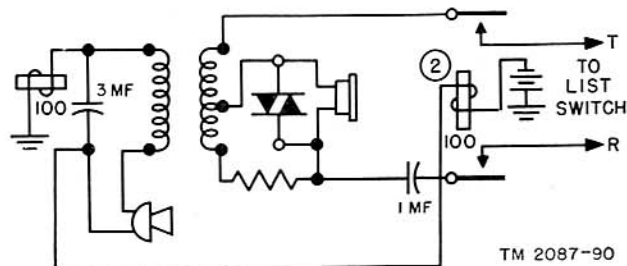

Figure 82. Operator's telephone circuit, schematic.

### 122. Dial and Dial Cord Circuit (fig. 83)

In this type switchboard, the dial and dial cord circuit are isolated from the other circuits. To use the dial, the plug of the dial cord is inserted in a trunk-dial jack. A break contact of the dial jack is opened by insertion of the plug and this disconnects the trunk equipment and leaves the line connected to the dial so that pulses are transmitted directly to the dial office equipment. A 500-ohm noninductive resistor in series with a 1-mf capacitor are connected across the dial contacts to reduce arcing during dialing. The dial plug must be removed from the trunk jack after dialing to permit an operator to talk and listen on the trunk circuit.

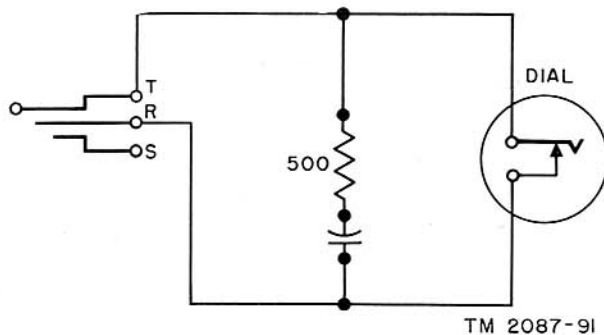

Figure 83. Dial and dial cord circuit, schematic.

### 123. Generator Circuit

In the normal position of the generator switch (fig. 68), ringing current is supplied from the magneto hand generator and in the operated position from a power generator. Figure 84 shows the circuit.

### 124. Cord Test Circuit (fig. 85)

Separate test circuits, each with its own test switch, are provided to test the operation of cord



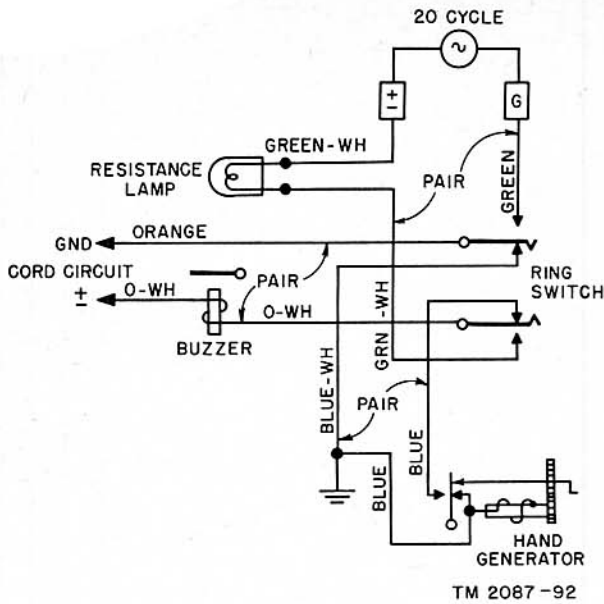

Figure 84. Generator circuit, schematic.

circuits when used with either common battery telephones or magneto telephones. A light associated with the common battery test circuit is used to indicate the ringing performance of a cord.

*a.* COMMON BATTERY CORD TEST CIRCUIT.

- (1) Inserting a cord plug into the common battery test jack bridges 10,000 ohms across the tip and ring conductors. This represents the minimum insulation of the line for which the cord circuit can function. Operating the test switch bridges a 500-ohm resistor across the 10,000 ohms. The combined resistance is approximately 467 ohms which repre-

sents the maximum resistance of a line loop including the telephone. Satisfactory operation of the cord circuit is indicated by the supervisory lamp lighting when the cord plug is inserted into the test jack. Ground on the sleeve of the test jack completes the circuit for the operation of cord circuit relay 1 or 2 which at a make contact in turn completes the circuit to light the corresponding supervisory lamp.

- (2) Operating the test switch is equivalent to answering the called telephone. It reduces the test circuit resistance to approximately 476 ohms so that cord circuit relay 3 or 4 operates and a break contact opens the circuit of the supervisory lamp which is extinguished. A satisfactory ringing condition of the cord is indicated by the test circuit lamp lighting when the cord ringing switch is operated while the test switch is in the normal position. Ringing current causes test circuit relay D to operate and close a make contact to complete the circuit for the test lamp which lights.

*b.* MAGNETO CORD TEST CIRCUIT. Inserting a cord plug into the magneto jack establishes a ringing circuit to the cord which is completed through make contacts of the test switch when it is operated. Operating the test switch represents ringing-off at a magneto telephone which causes the cord circuit supervisory lamp to light as described for the universal cord circuit, magneto to magneto

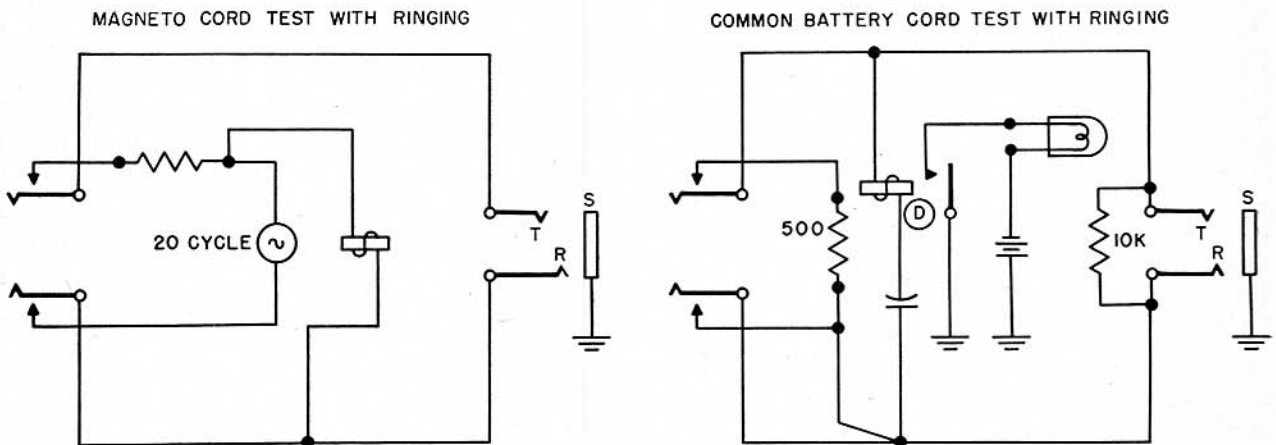

Figure 85. Cord test circuit, schematic.

TM 2087-93

connections (par. 120). The cord circuit is further tested by operating the listening switch which opens the supervisory lamp locking circuit and extinguishes the supervisory lamp.

### 125. Line Pilot Circuit (fig. 86)

A separately fused circuit supplies battery to the line lamps in the left panel while another circuit supplies the right panel. In each circuit there is a line pilot relay through which the current to the line lamps flows. Whenever a line lamp lights, a line pilot relay operates and a make contact closes the circuit to light the associated line pilot lamp. When the operator answers by inserting a cord circuit plug into a line jack, the line relay circuit is opened at line jack spring contacts. This causes the line relay to release, and a contact to open the circuit of the line lamp and the line pilot relay. If there are no other unanswered calls, the line pilot relay releases a contact and opens the circuit to extinguish the line pilot lamp.

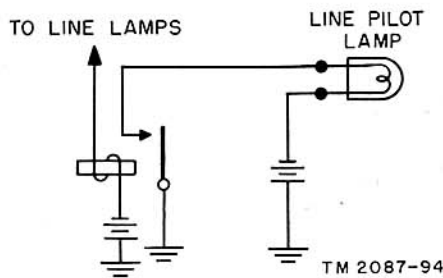

Figure 86. Line pilot circuit, schematic.

### 126. Supervisory Pilot Circuit (fig. 87)

Ground is connected to the night alarm relay in a circuit to which battery is fed through a separate fuse to the supervisory pilot lamp. This supplies current to light the lamp whenever a cord supervisory lamp lights and the supervisory pilot relay operates. The supervisory pilot lamp circuit is from battery through the lamp, a make contact of the supervisory pilot relay, and the night alarm relay to ground. The lamp lights whenever the supervisory pilot relay is operated.

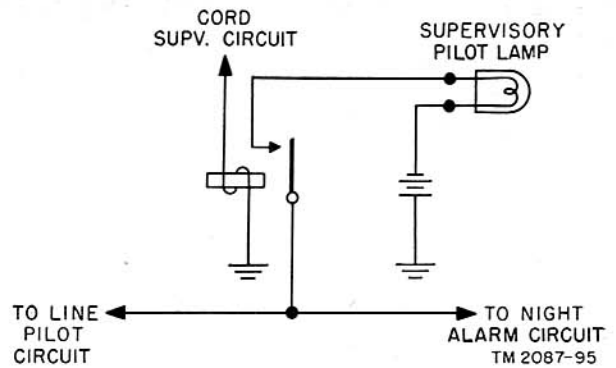

Figure 87. Supervisory pilot circuit, schematic.

### 127. Night Alarm Circuit (fig. 88)

Ground connected to the night alarm relay completes the circuit from battery connected to both the line pilot lamps and the supervisory pilot lamp. When one of the pilot lamps lights, current through the night alarm relay causes it to operate and complete the night alarm circuit through a night alarm switch contact. The switch must be in the operated position for the alarm bell to ring. Restoring the switch to normal disconnects the circuit.

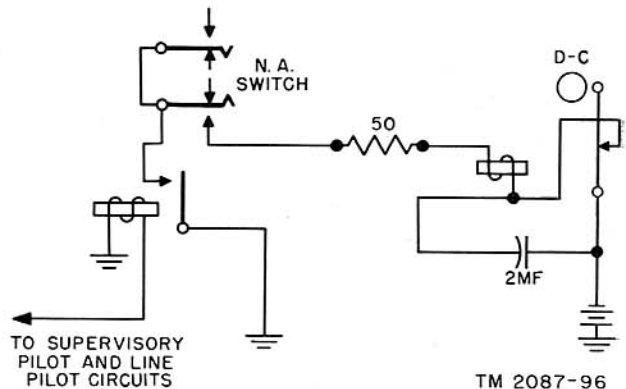

Figure 88. Night alarm circuit, schematic.

### 128. Battery Cut-off Switch Circuit (fig. 89)

The Stromberg-Carlson switchboard is provided with a battery cut-off switch to disconnect battery from the switchboard when telephone service is discontinued. Battery is connected (fig. 89)

when the battery switch is in the operated position.

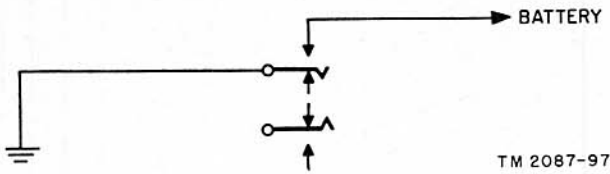

Figure 89. Battery cut-off switch circuit, schematic.

### 129. Ground Circuit

Figure 90 is a schematic of the ground circuit for the Stromberg-Carlson type of Switchboard SB-53( )/FTC. Note that connections are provided to the relay gate, jack frame, and switch frame.

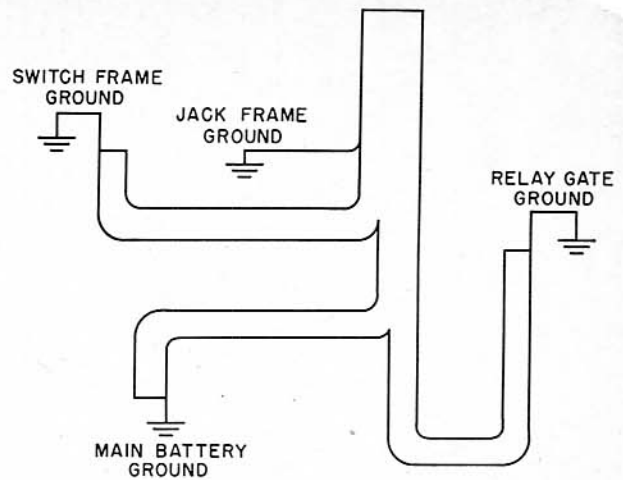

Figure 90. Ground circuit, schematic.

## Section II. PREREPAIR PROCEDURES, POWER REQUIREMENTS, AND INSPECTING, STRIPPING, AND CLEANING INSTRUCTIONS

### 130. General

Prerepair procedures outlined in section III, chapter 4, part two of this manual covering Switchboard SB-53( )/FTC (Kellogg type) also apply in the case of the Stromberg-Carlson type of Switchboard SB-53( )/FTC. Common materials listed in paragraph 61 are essential in repair work on both types of the switchboard. Likewise the test equipment listed in paragraph 62 is used to test either type of switchboard.

### 131. Repair Required

Tools required for repair work on Switchboard SB-53( )/FTC (Stromberg-Carlson universal type 106) are those issued in the tool roll furnished with each switchboard. These tools are listed and illustrated in paragraph 115.

### 132. Power Requirements

Power requirements for performance of tests on the switchboard are described in section IV, chapter 4, part two of this manual. The power requirements are indicated for the switchboard itself and for the test equipment used in testing.

## Section III. TROUBLE LOCATION AND FINAL TESTING

### 133. Introduction

Before performing trouble location and final tests on the switchboard, refer to paragraphs 70 through 75 of this manual covering sectionalization and localization of trouble and setting up the equipment for tests. Paragraphs 134 through 143 outline tests to be performed on the various switchboard circuits. They also describe what troubles are indicated by faulty operation, and outline corrective steps which can be taken to remedy the trouble.

### 134. Cord Test Circuit (fig. 91)

Check resistors, switch contacts, and wiring of the cord test circuit by resistance measurements with Test Set I-49. Insert the plug of a test cord connecting the test set into the cord circuit test jack. Test the ringing efficiency of the cord test circuit by applying ringing current.

#### a. COMMON BATTERY CORD TEST CIRCUIT.

- (1) *Test switch normal.* With the test cord plug in the common battery test jack, determine the resistance of the 10,000-ohm

resistor winding; it should be approximately 10,000 ohms. If there is a 15 percent difference, analyze for trouble as follows:

<i>Possible trouble</i>	<i>Analysis</i>
Open circuit-----	Open resistor. Test plug not making contact with tip or ring spring of common battery jack.
High resistance-----	Open wiring. Defective resistor. High-resistance test plug contact with tip or ring spring of common battery jack.
Low resistance-----	Defective resistor. 500-ohm resistor connected through permanently made contacts of defective test switch. Relay D connected across resistor through defective capacitor.

(2) *Test switch operated.* With test switch operated, the resistance of the 500-ohm resistor should be approximately 476 ohms. If there is a 15 percent difference, analyze for trouble as follows:

<i>Possible trouble</i>	<i>Analysis</i>
Resistance of 10,000 ohms unchanged.	Open test switch contacts.
High resistance-----	Defective resistor. High resistance contacts of test switch.
Low resistance-----	Wrong type resistor installed for 500 ohms. Defective resistor.

(3) *Testing ringing.* Insert a cord circuit plug into the common battery jack and operate the associated ringing key. If the cord test circuit lamp does not light, analyze for trouble as follows:

<i>Possible trouble</i>	<i>Analysis</i>
Relay does not operate-----	Open wiring. Relay D winding open. Relay D contact does not close. Battery or ground disconnected. Lamp does not make contact in socket. Lamp burned out.

(4) *Testing sleeve grounding.* To verify that the sleeve of the cord circuit test jack is grounded, use Test Set TS-190/U. Test from negative battery to the metal sleeve. If it is not grounded, establish a ground connection.

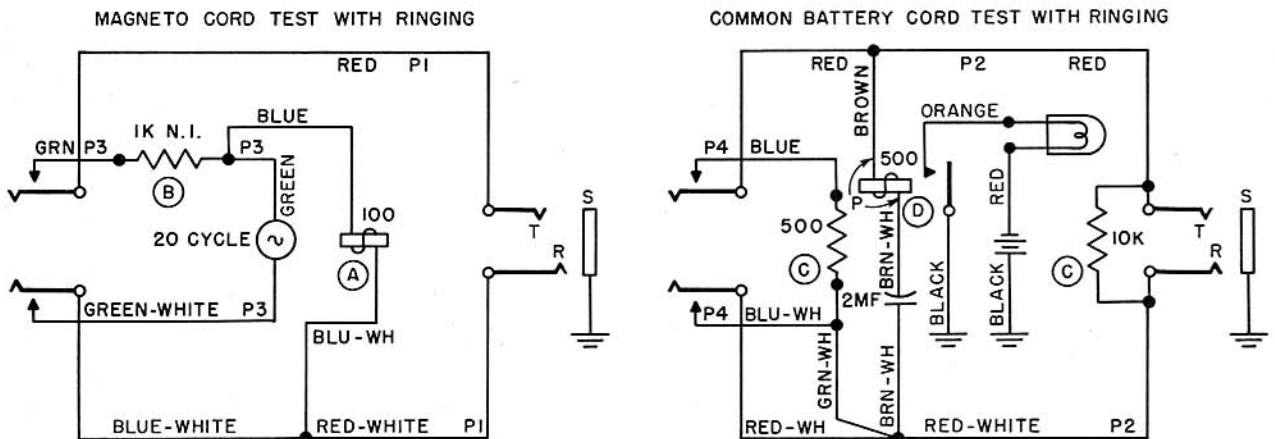

Figure 91. Cord test circuit, wiring diagram.

TM 2087-99

b. MAGNETO CORD TEST CIRCUIT.

(1) *Preparation of circuit.* If the ringing-current generator is connected to the switchboard, disconnect the ungrounded lead from the switchboard terminals. When the ringing condition is tested, connect the ringing terminals.

(2) *Resistance check.* With the test cord in the magneto jack and the test switch operated, determine the resistance of coil A in series with resistor B. It should be approximately 1,100 ohms. If there is a 15 percent difference analyze the trouble as follows:

<i>Possible trouble</i>	<i>Analysis</i>
Open circuit-----	Open coil A or resistor B. Open test switch contact. Test plug not making contact with tip or ring spring of jack.
High resistance-----	Defective resistors. High-resistance test plug contact with tip or ring sleeve of magneto jack.
Low resistance-----	Defective resistors.

(3) *Ringling condition test.* With the test cord in the jack, the ringing terminals connected together, and the test switch operated, determine the resistance. Coil A is short-circuited by connecting the ringing terminals together so that the resistance of the 1,000-ohm resistor B is determined. If there is a 15 percent difference, analyze the trouble as follows:

<i>Possible trouble</i>	<i>Analysis</i>
High resistance-----	High resistance connection in ringing wiring.
Low resistance-----	Wrong type resistor installed.

### 135. Operator's Telephone Circuit (fig. 92)

a. VARISTOR. Unsolder and remove the black wire from induction coil terminal T and then test varistor as described for Kellogg universal switchboard (par. 50).

#### b. RECEIVING CIRCUIT.

- (1) Connect induction coil terminals T and LT to ringing current through the type network described for testing the Kellogg universal switchboard (par. 50).
- (2) Ringing tone should be heard in the receiver of the operator's telephone set connected to the jack of the operator's telephone circuit.
- (3) If the tone is not heard, analyze for trouble as follows:

<i>Possible trouble</i>	<i>Analysis</i>
Open or cross of tip and ring wiring.	Check wiring for presence of tone.

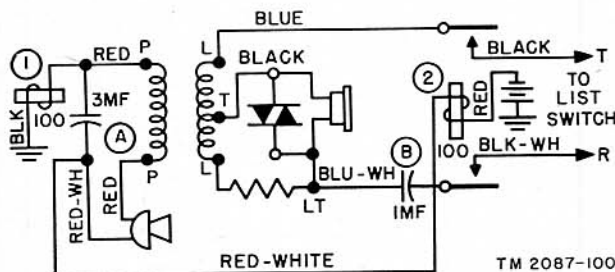

Figure 92. Operator's telephone circuit, wiring diagram.

### c. TRANSMITTING CIRCUIT.

#### (1) Test of transmitting circuit.

- (a) Connect an operator's telephone set to the operator's circuit jack.
- (b) Tap the transmitter or blow into the transmitter.
- (c) The tapping or blowing should be heard in the receiver.
- (d) If the tapping or blowing is not heard, analyze for trouble as follows:

<i>Possible trouble</i>	<i>Analysis</i>
Open in transmitter circuit---	Check wiring for continuity of circuit.
Short-circuited capacitor A---	Check for short circuit of capacitor A.

#### (2) Relay 2 operation.

- (a) Relay 2 should operate when the operator's telephone set is connected to the operator's telephone circuit jack.
- (b) If relay 2 does not operate, analyze for trouble as follows:

<i>Possible trouble</i>	<i>Analysis</i>
Relay 2 windings short-circuited.	Check for short circuit of relay 2.

### 136. Cord Circuit (fig. 93)

Perform these tests on both ends of cord circuit.

#### a. COMMON BATTERY OPERATION OF CORD CIRCUIT.

##### (1) Test of sleeve circuit and relay 1 and 2.

- (a) Connect the answer or call cord to the jack of the common battery cord test circuit.
- (b) The cord supervisory answer or call lamp should light, indicating that relay 1 or 2 has operated. The circuit for relay 1 or 2 operation is from ground on the sleeve of the jack of the cord test circuit through the 500-ohm winding of relay 1 or 2 to negative battery. The answer supervisory lamp circuit is from battery through a 1.7-ohm relay winding, relay 2 make contact, and relay 4 break contact to ground.

(c) If the supervisory lamp does not light, analyze for trouble as follows:

<i>Possible trouble</i>	<i>Analysis</i>
When answer lamp does not light relay 1 does not operate.	Check winding.
Blown fuse-----	Check fuse.
Open wiring-----	Check continuity of relay 1 circuit.



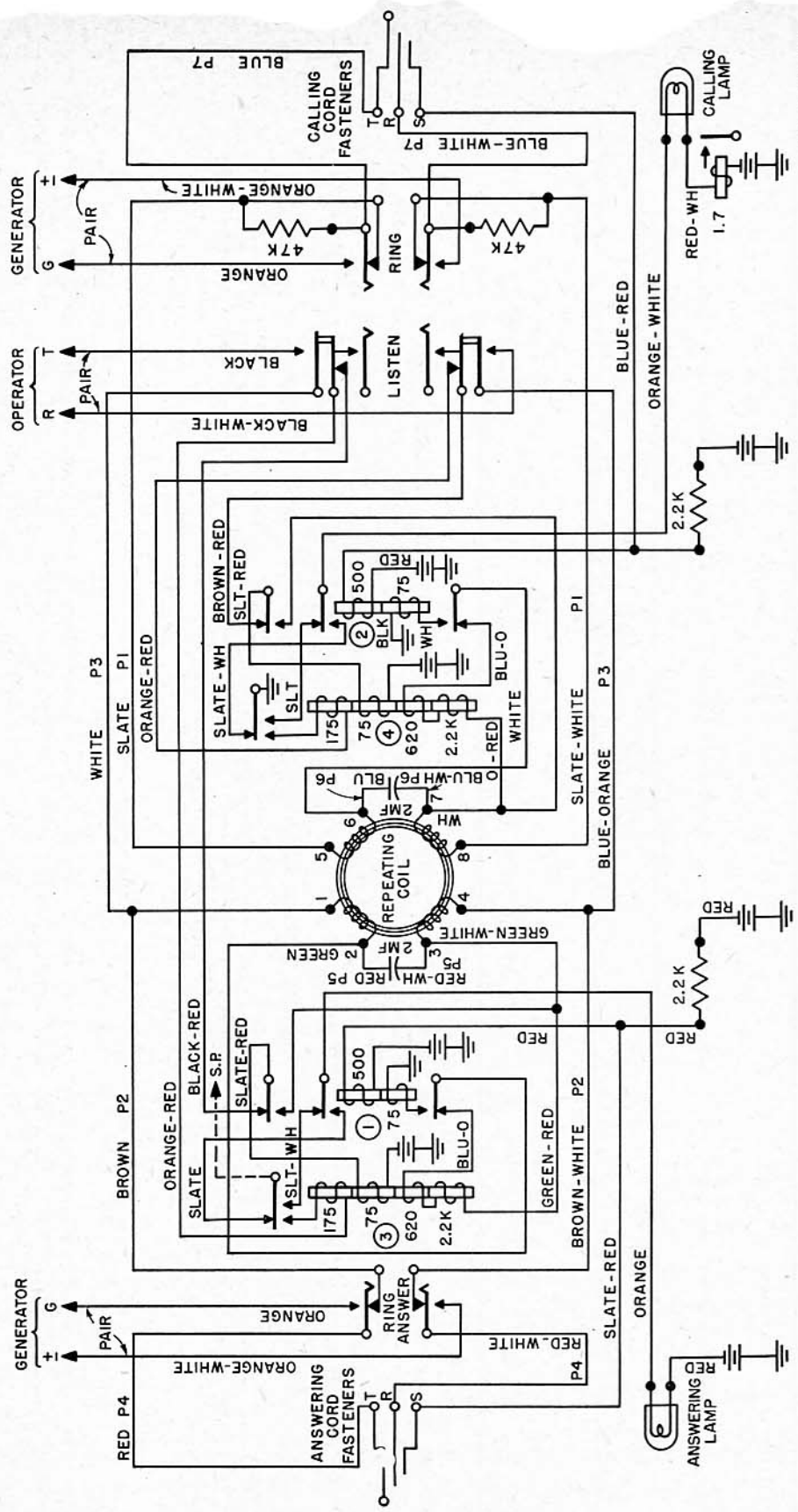

TM 2087-101

Figure 93. Cord circuit, wiring diagram.

<i>Possible trouble</i>	<i>Analysis</i>
Relay 1 or relay 3 contacts not closed.	Check adjustment.
Supervisory pilot relay winding open.	Check winding.
Supervisory lamp burned out.	Replace lamp.
Battery or ground disconnected from supervisory lamp circuit.	Check circuit.
Open wiring in supervisory lamp circuit.	Check continuity.

When the call lamp does not light, all possible troubles as listed for the answer lamp may exist, except such troubles caused by the supervisory pilot relay.

(2) *Operating test of relay 3 or 4.*

- (a) Operating the test switch of the cord test circuit should cause relay 3 or 4 to operate and extinguish the supervisory lamp of the cord being tested.
- (b) If the lamp is not extinguished, analyze for trouble as follows:

<i>Possible trouble</i>	<i>Analysis</i>
Relay 3 or 4 does not operate.	Check for open 75-ohm winding of relay 3 or 4 and 75-ohm winding of relay 1 or 2.
Relay 3 or 4 make contacts do not close.	Check adjustment of relay 3 or 4.
Relay 1 or 2 make contacts do not close.	Check adjustment of relay 1 or 2.

(3) *Release test of relay 3 or 4.*

- (a) Restoring the test switch to normal should cause relay 3 or 4 to release and again light the supervisory lamp.
- (b) If lamp does not light, analyze for trouble as follows:

<i>Possible trouble</i>	<i>Analysis</i>
Relay 3 or 4 does not release.	Check adjustment of relay 3 or 4.

(4) *Flashing test of relay 3 or 4.*

- (a) Operate and restore the cord test circuit switch at the rate of three times per second. This applies a flashing test to relay 3 or 4 and causes the supervisory lamp to flash.
- (b) The lamp should be extinguished on each operation of the switch and should light again when the switch is restored to the nonoperated position. This indicates that relay 3 or 4 operates properly.

- (c) If the lamp fails to respond to the switch operation, analyze for trouble as follows:

<i>Possible trouble</i>	<i>Analysis</i>
Failure of relay 3 or 4 to operate and release at the flashing rate.	Check adjustment of relay 3 or 4.

(5) *Repeating coil test.*

- (a) Terminate a resistance network, such as is used for testing the operator's telephone circuit (par. 135) on a jack and energize with ringing current.
- (b) Plug either cord of a cord circuit into the jack.
- (c) Ringing tone should be heard across the tip and ring of the plug of the other cord by using Test Set TS-190/U.
- (d) If ringing tone is not heard, test for trouble as follows:

<i>Possible trouble</i>	<i>Analysis</i>
Open in wiring-----	Check continuity of wiring.
Open in repeating coil winding	Check repeating coil.

(6) *Listen switch talking test.*

- (a) With both cord circuit cords disconnected and the associated listen key in the operated position, tap the transmitter or blow into the transmitter.
- (b) Listen across the tip and ring of the plug of each cord in turn with Test Set TS-190/U. The tapping or blowing should be heard.
- (c) If the tapping or blowing is not heard, analyze for trouble as follows:

<i>Possible trouble</i>	<i>Analysis</i>
Listen switch contacts to operator's circuit not closed.	Check adjustment of switch.
Ring switch contacts not closed.	Check adjustment of switch.

(7) *Ringling test.*

- (a) Connect a cord circuit cord to the jack of the common battery cord test circuit and leave the test switch normal.
- (b) Operate the ring-answer switch or listen switch to the ring position for the call cord.
- (c) Relay D of the test circuit should operate as indicated by the cord test circuit.
- (d) Ringing tone should not be heard in the operator's receiver while a ring switch is operated.
- (e) If lamp does not light or if ringing tone is heard, analyze for trouble as follows:

*Possible trouble*

*Analysis*

If lamp does not light, ring switch make contacts do not close.

If ringing tone is heard in receiver, ring switch break contacts do not open.

Check adjustment of ring switch contacts.

Check adjustment of ring switch contacts.

**b. MAGNETO OPERATION OF CORD CIRCUIT.** Only those features not tested by the common battery operation tests are included in the tests for operation of the cord circuit with magneto telephones.

(1) *Answer cord recall test.*

(a) Connect the answer cord of the cord circuit to the jack of the magneto cord test circuit.

(b) Operating the magneto cord test circuit test switch energizes the 620-ohm winding in series with the 2,200-ohm winding of relay 3. This causes relay 3 to operate and at contacts complete a locking circuit for itself through the 75-ohm and 175-ohm windings in series with the supervisory pilot circuit. The answer cord supervisory lamp circuit is also completed at a relay 3 contact through the supervisory pilot circuit so that the answer cord supervisory lamp lights.

(c) If the answer cord supervisory lamp does not light, analyze for trouble as follows:

*Possible trouble*

*Analysis*

Relay 3 does not operate.....	Check for open in 620-ohm, 2,200-ohm, and 175-ohm windings of relay 3.
Relay 1 contact not closed....	Check adjustment of relay 1 contacts.
Relay 3 does not lock in operated condition.	Check for open contacts of relay 3 and listen switch.
Open wiring.....	Check continuity of lamp and relay 3 circuits.

(2) *Call cord recall test.* Except for relay 4 being involved and there being no supervisory pilot circuit, the call cord tests and possible troubles are identical with those for the answer cord.

(3) *Listen switch supervisory lamp test.*

(a) Connect a test cord to the magneto test jack and operate the test switch to light the cord supervisory light.

(b) Operate the listen switch of the cord circuit.

(c) The supervisory lamp should be extin-

guished because its circuit is opened at a break contact of the listen switch.

(d) If the lamp is not extinguished, analyze for trouble as follows:

*Possible trouble*

*Analysis*

Break contact of listen switch does not open. Check switch contact adjustment.

### 137. Line Circuit

**a. COMMON BATTERY LINE CIRCUIT** (fig. 94). Operate the night alarm switch to its off position to silence the alarm while testing.

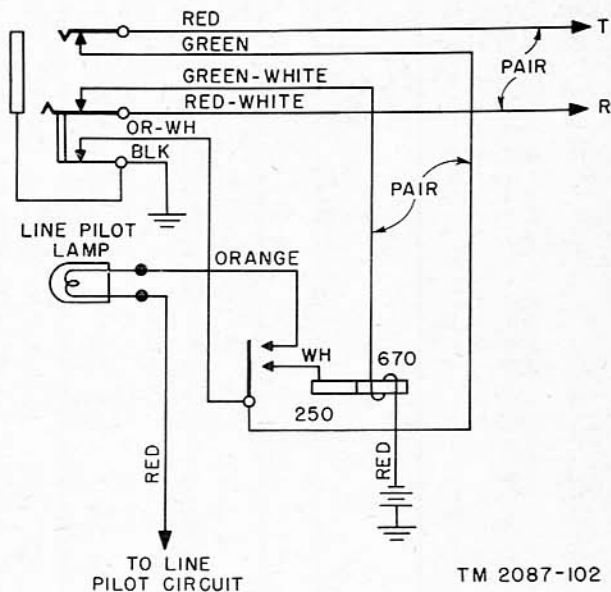

Figure 94. Universal line circuit connected for common battery operation, wiring diagram.

(1) *Ground on line jack sleeve.*

(a) Connect a cord circuit answer cord to the line jack.

(b) The answer cord supervisory lamp should light.

(c) If the supervisory lamp does not light, analyze for trouble as follows:

*Possible trouble*

*Analysis*

Ground not connected to sleeve of line jack.	Check sleeve ground connection.
Open in wiring.....	Check for continuity.
Plug contact not making contact with jack sleeve.	Check for dirty line jack sleeve.

(2) *Line relay operation.*

(a) Connect a 750-ohm resistor across the tip and ring line terminals on the terminal board.

(b) The line relay should operate as indicated when the line lamp lights.

- (c) If the line lamp does not light, analyze for trouble as follows:

Possible trouble	Analysis
Line lamp burned out-----	Replace.
Line relay contact in lamp circuit not closed.	Check relay adjustment.
Line pilot relay winding open.	Check relay winding.
Line lamp battery disconnected.	Check for battery.
Line lamp battery fuse blown.	Replace fuse.
Line relay not operated-----	Check for open in 670-ohm winding.
Line relay battery disconnected.	Check for battery.
Line relay battery fuse blown.	Replace fuse.
Line jack springs not closed.	Check for adjustment.
Open in wiring-----	Check continuity.

(3) *Line relay release.*

- (a) After the line relay has been operated and the line lamp lighted, connect answer cord plug to line jack.
- (b) The line relay should release as indicated by the line lamp being extinguished.
- (c) If line lamp is not extinguished, analyze for trouble as follows:

Possible trouble	Analysis
Line jack spring contacts not opened so that line relay remains operated.	Check adjustment of line jack springs.

b. MAGNETO LINE CIRCUIT (fig. 95).

- (1) *No ground on line jack sleeve.*

- (a) Connect a cord circuit plug to the line jack.

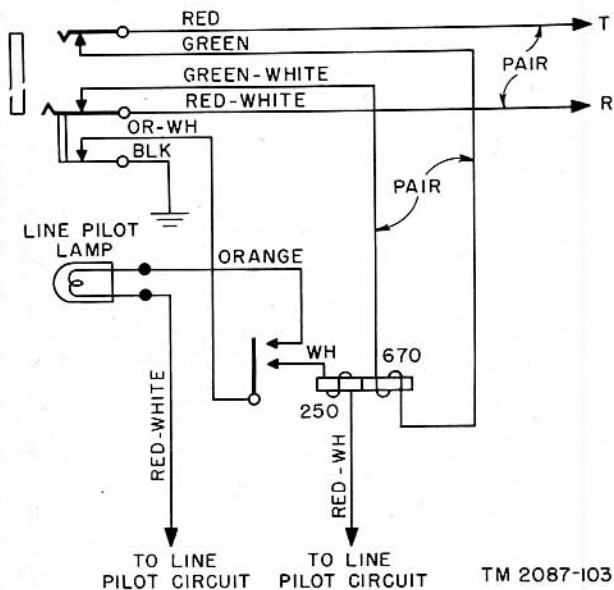

Figure 95. Universal line circuit connected for magneto operation, wiring diagram.

- (b) The cord supervisory lamp should not light.

- (c) If the cord supervisory lamp lights, analyze for trouble as follows:

Possible trouble	Analysis
Ground connected to line jack sleeve.	Check for ground.

(2) *Line relay operation.*

- (a) Connect ringing current to the tip and ring line terminals on the terminal strip through a 10,000-ohm resistor.
- (b) The line relay should operate as indicated when the line lamp lights.
- (c) If the line lamp does not light, analyze for trouble as follows:

Possible trouble	Analysis
Lamp burned out-----	Replace.
Line relay contact in lamp circuit not closed.	Check relay adjustment.
Line pilot relay winding open.	Check relay winding.
Line lamp battery fuse blown.	Replace fuse.
Line relay not operated-----	Check for open relay winding.
Battery connected from line lamp circuit.	Check for battery.
Line jack contacts not closed.	Check for adjustment.
Open in wiring-----	Check continuity.

- (d) On removing ringing current, the line relay remains operated as indicated by the line lamp remaining lighted.
- (e) If the line lamp does not remain lighted, analyze for trouble as follows:

Possible trouble	Analysis
Line relay 670-ohm or 250-ohm winding open.	Check relay windings.

(3) *Line relay release.*

- (a) After the line relay has been operated and the line lamp lighted, connect the answer cord plug to the line jack.
- (b) The line relay releases as indicated by the line lamp being extinguished.
- (c) If the line lamp is not extinguished, check for trouble as follows:

Possible trouble	Analysis
Line jack spring contacts not opened so that line relay remains operated.	Check adjustment of line jack springs.
Lamp circuit not opened at relays.	Check adjustment of relay contact when line relay releases.

138. Line Pilot Circuit (fig. 96)

The line pilot circuit in the Stromberg-Carlson universal type 106 switchboard functions the same



as the line pilot circuit in the Kellogg universal switchboard. It is tested in the same manner and is subject to the same troubles as discussed for the Kellogg universal type switchboard (par. 54).

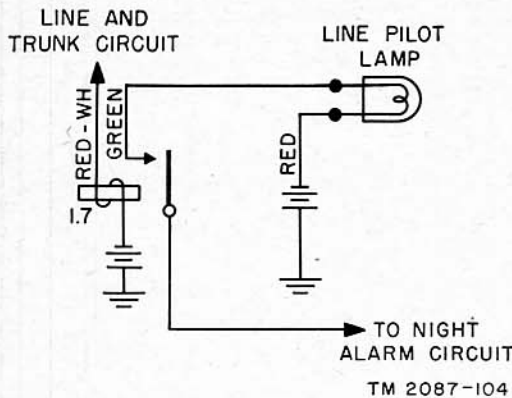

Figure 96. Line pilot circuit, wiring diagram.

### 139. Universal Trunk Circuit (fig. 97)

#### a. CALL TO COMMON BATTERY EXCHANGE.

- (1) Connect call cord to trunk line jack. A line jack make spring contact is closed, to complete the operation of relay 2.
- (2) On closing, a make contact of relay 2 completes the circuit to connect inductor 4 across the trunk line which completes the trunk loop to the called common battery office.
- (3) Using Test Set TS-190/U, test across the trunk tip and ring terminals on the terminal strip. The test should indicate that the trunk loop is closed.
- (4) If the test does not indicate that the trunk loop is closed, analyze for trouble as follows:

<i>Possible trouble</i>	<i>Analysis</i>
Inductor 4 winding open.....	Check inductor.
Make contact of relay 2 not closed.	Check relay adjustment.
Open wiring to inductor 4.....	Check continuity.

- (5) If it is found that relay 2 has not operated, analyze for trouble as follows:

<i>Possible trouble</i>	<i>Analysis</i>
Open winding of relay 2.....	Check winding.
Battery or ground disconnected from relay 2 circuit.	Check for battery and ground.
Battery fuse blown.....	Replace fuse.
Trunk line jack spring contact not closed.	Check adjustment of line jack spring contacts

b. CALL TO MAGNETO EXCHANGE. In a trunk to a magneto exchange, inductor 4 is not used. Connecting the call cord to the trunk line jack, how-

ever, causes the operation of relay 2. If it does not operate, analyze for trouble in the same manner as described for a call to a common battery exchange in *a* above.

#### c. CALL TO DIAL EXCHANGE.

- (1) The trunk circuit to a dial exchange is subject to the same possible troubles as those analyzed for a trunk call to a common battery exchange. In addition, the dial feature must be tested.
- (2) Connect a call cord to the trunk line jack and connect the dial cord to trunk dial jack.
- (3) At a dial jack break spring contact, the trunk equipment is disconnected from the trunk line.
- (4) Connect an operator's telephone set to the operator's jacks, and operate the talk switch to the talk and listen position.
- (5) Tap the transmitter or blow into the transmitter.
- (6) The tapping or blowing should not be heard when listening across the trunk tip and ring terminals on the terminal board.
- (7) If the tapping or blowing is heard, analyze for trouble as follows:

<i>Possible trouble</i>	<i>Analysis</i>
Dial jack break spring contact not opened.	Check dial jack spring adjustment.

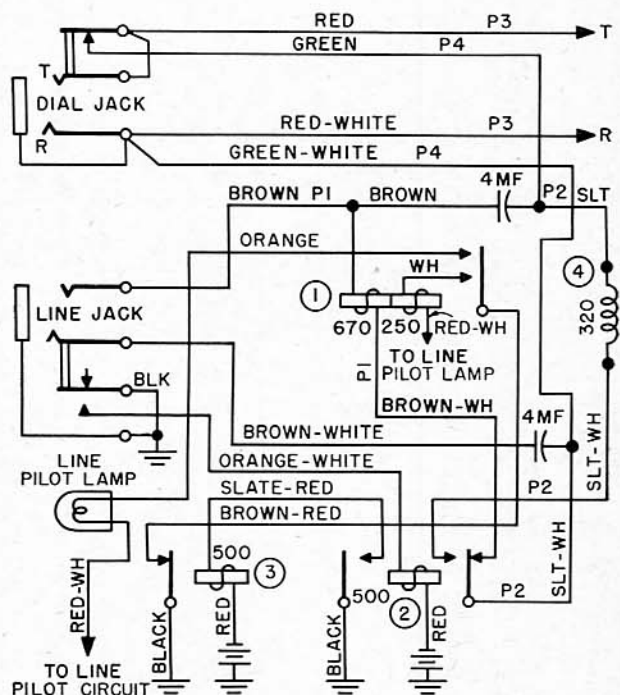

TM 2087-105

Figure 97. Universal trunk circuit, wiring diagram.



*d.* CALL FROM ANOTHER EXCHANGE.

- (1) Apply ringing current through 10,000-ohm resistor to trunk tip and ring terminal on terminal board. Ringing current through the 670-ohm winding of relay 1 causes relay 1 to operate.
- (2) A make contact of relay 1 closes and completes the circuit which lights the trunk line lamp.
- (3) If the trunk line lamp does not light, analyze for trouble as follows:

<i>Possible trouble</i>	<i>Analysis</i>
Relay 1 winding open-----	Check winding.
Break contact of relay 2 not closed.	Check relay 2 adjustment.
Make contact of relay 1 not closed.	Check relay 1 adjustment.
Break contact of relay 3 not closed.	Check relay 3 adjustment.
Open wiring-----	Check continuity.

- (4) When operating, relay 1 closes another make contact which completes a locking circuit for itself through a 250-ohm winding. The trunk line lamp should consequently remain lighted after ring current has been removed from the trunk circuit.
- (5) If the trunk line lamp does not remain lighted, analyze for trouble as follows:

<i>Possible trouble</i>	<i>Analysis</i>
Relay 1 make contact does not close to complete locking circuit.	Check relay 1 adjustment.
Open 250-ohm relay 1 winding.	Check winding.

- (6) Connect answer cord to trunk line jack as in answering a call.
- (7) Relay 2 should operate. Its operation and possible trouble have been discussed in connection with calls to a common battery exchange.
- (8) When operating, relay 2 closes a make contact to complete the circuit for the operation of relay 3. Operation of relay 3 is indicated by the trunk line lamp being extinguished.
- (9) If the lamp is not extinguished, analyze for trouble as follows:

<i>Possible trouble</i>	<i>Analysis</i>
Make contact of relay 2 not closed.	Check adjustment of relay 2.
Relay 3 winding open-----	Check winding.
Battery or ground disconnected from relay 3 circuit.	Check for battery and ground.
Battery fuse blown-----	Replace fuse.

*Possible trouble*

*Analysis*

Relay 3 break contact not opened. Check relay 3 adjustment.

### 140. Supervisory Pilot Circuit (fig. 98)

In the Stromberg-Carlson universal type 106 switchboard, the supervisory pilot lamp functions only with the supervisory lamp of the answer cord. The circuit is tested in the same manner and is subject to the same troubles as discussed for the Kellogg universal type switchboard (par. 55).

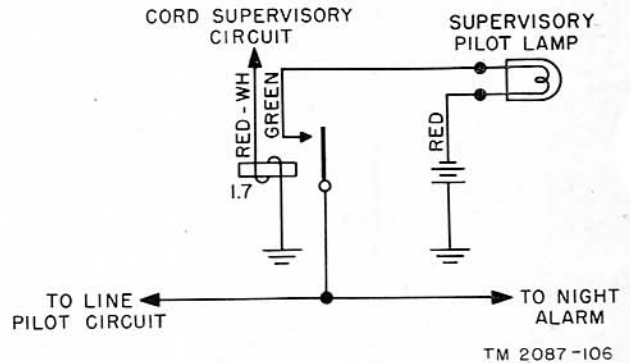

Figure 98. Supervisory pilot circuit, wiring diagram.

### 141. Night Alarm Circuit (fig. 99)

a. The alarm circuit in the Stromberg-Carlson universal type 106 switchboard functions the same as the alarm circuit in the Kellogg universal switchboard (par. 56).

b. The circuit in the Stromberg-Carlson switchboard contains a 50-ohm resistor, a 15-ohm inductor to limit the amount of current through the bell, and a 2-mf capacitor across the bell terminals to reduce contact arcing.

c. The circuit is tested in the same manner and is subject to the same trouble as discussed for the Kellogg switchboard (par. 55).

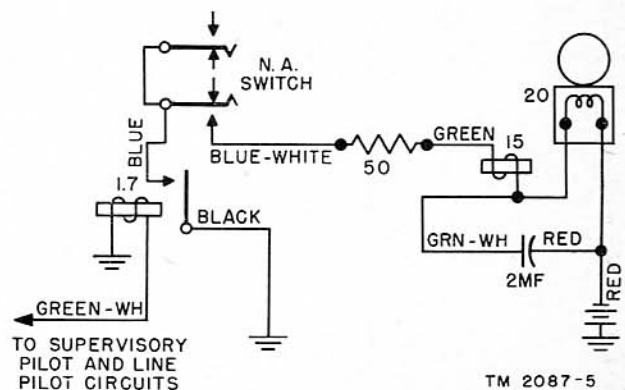

Figure 99. Night alarm circuit, wiring diagram.

d. If the night alarm bell does not ring, make additional analysis for trouble as follows:

<i>Possible trouble</i>	<i>Analysis</i>
Open in 50-ohm resistor or 15-ohm inductor.	Check resistor and inductor.
Short-circuited 2-mf capacitor.	Check capacitor.

e. If bell rings and there is excessive arcing at contacts, analyze for trouble as follows:

<i>Possible trouble</i>	<i>Analysis</i>
Open 2-mf capacitor-----	Check capacitor.

## 142. Dial and Dial Cord Circuit (fig. 100)

### a. CONNECTION OF DIAL CORD.

- (1) Connect dial cord to trunk dial jack.
- (2) Connect Test Set TS-190/U across the trunk tip and ring terminal on the terminal board.
- (3) Connect the operator's headset to the operator's jacks.
- (4) Tap transmitter or blow into transmitter.
- (5) The tapping or blowing should not be heard in the receiver of Test Set TS-190/U because the circuit is open at a dial jack break spring contact.
- (6) If tapping or blowing is heard, analyze for trouble as follows:

<i>Possible trouble</i>	<i>Analysis</i>
Dial jack break spring contact not open.	Check adjustment of jack springs.

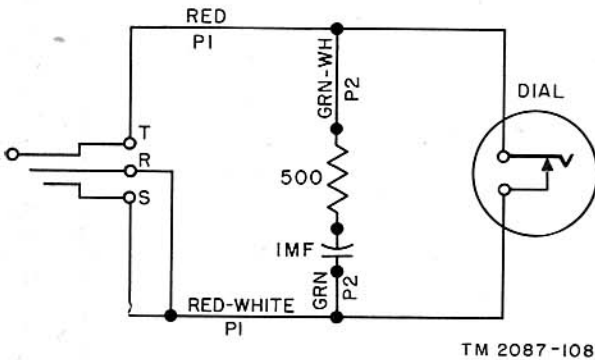

TM 2087-108

Figure 100. Dial and dial cord circuit, wiring diagram.

### b. DIAL OPERATION.

- (1) Connect dial cord to dial jack.
- (2) On the terminal board, connect battery through 750 ohms to the trunk tip terminal, and connect ground to the ring terminal.
- (3) Connect Test Set TS-190/U across the trunk tip and the ring terminals on the terminal board.

- (4) Operate the dial for the zero digit and then release the dial.
- (5) Dial pulse clicks should be heard in receiver of Test Set TS-190/U because of the dial contacts closing and opening.
- (6) If the dial pulse clicks are not heard, analyze for trouble as follows:

<i>Possible trouble</i>	<i>Analysis</i>
Dial contacts not opening and closing.	Check dial contact adjustment.
1 mf capacitor shorted which completes short circuit across dial contacts and renders contacts ineffective for transmitting dial pulses.	Check capacitor for short circuit.

### c. DIAL CONTACT SPARKING.

- (1) With battery and ground connected for dial operation, observe the dial contacts while opening and closing.
- (2) If dial contact sparking or arcing is observed, analyze for trouble as follows:

<i>Possible trouble</i>	<i>Analysis</i>
Open capacitor-----	Check capacitor.
Open resistor-----	Check resistor.
Open wiring-----	Check continuity.

## 143. Battery Switch Circuit (fig. 101)

a. BATTERY SWITCH. Battery is supplied to the switchboard equipment through a battery switch. To connect battery, the switch must be operated in the depressed or pushed-in position.

### b. BATTERY SWITCH TEST.

- (1) Connect a cord circuit to a line jack.
- (2) The cord supervisory lamp should light.
- (3) To disconnect battery from the switchboard equipment, operate the battery switch to the pulled-out position.
- (4) The cord supervisory lamp should be extinguished.
- (5) If the cord supervisory lamp is not extinguished, analyze for trouble as follows:

<i>Possible trouble</i>	<i>Analysis</i>
Battery switch contacts not opened.	Check adjustment of switch contacts.

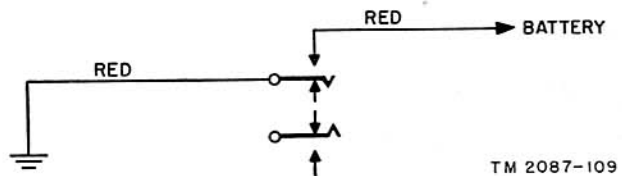

TM 2087-109

Figure 101. Battery switch circuit, wiring diagram.

## Section IV. APPARATUS ADJUSTMENTS AND REQUIREMENTS

### 144. General

Before proceeding to make the adjustments and repairs outlined in this section, refer to the paragraphs listed below. The subject matter in these paragraphs pertains equally to the Kellogg type Switchboard SB-53( )/FTC and the Stromberg-Carlson universal type 106 Switchboard SB-53( )/FTC.

Paragraph:	Title
87.....	Removal and replacement of parts.
88.....	Line jacks and line lamp jacks.
90.....	Hand generator.
91.....	Cords and plugs.
92.....	Switches and jacks.
93.....	Dials
95.....	Audible alarms.

### 145. Switches, Jacks, and Relays

Refer to TM 11-4302 for general information covering the care and adjustment of Stromberg-Carlson type switches, jacks, and relays. Electrical requirements for individual relay windings, spring terminal arrangements, and coil resistances will be found in figures 102 through 110 which follow.

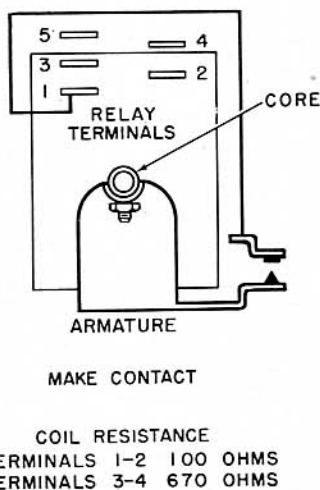

CURRENT FLOW IN AMPERES				
WINDING	TEST		READJUST	
	OPERATE	RELEASE	OPERATE	RELEASE
3-4	0.015	OPEN	0.015	OPEN

TM 2087-130

Figure 102. Winding and spring terminal arrangement of Stromberg-Carlson 192-A line relay, terminal end view.

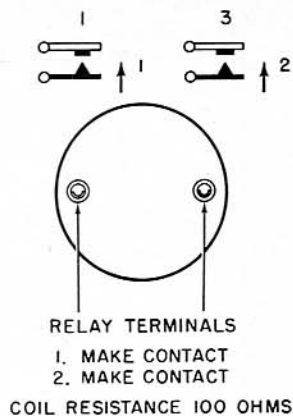

CURRENT FLOW IN AMPERES				
TEST			READJUST	
SOAK	OPERATE	NON-OPERATE	OPERATE	NON-OPERATE
	0.026	0.010	0.026	0.010

TM 2087-129

Figure 103. Winding and spring terminal arrangement of Stromberg-Carlson 204-ZAA operator's circuit relay, terminal end view.

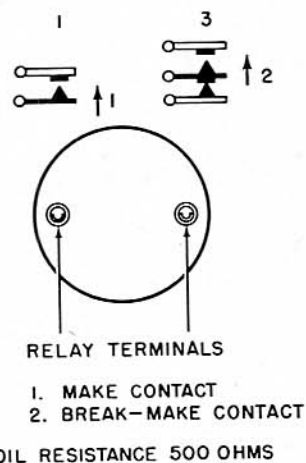

CURRENT FLOW IN AMPERES			
TEST		READJUST	
OPERATE	NON-OPERATE	OPERATE	NON-OPERATE
0.023	0.007	0.023	0.007

TM 2087-127

Figure 104. Winding and spring terminal arrangement of Stromberg-Carlson 206-ZAC trunk relay, terminal end view.

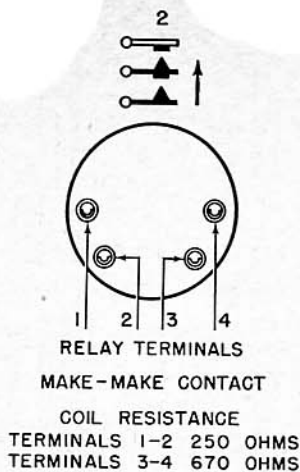

RELAY	CURRENT FLOW IN AMPERES				
	TEST			READJUST	
	SOAK	OPERATE	RELEASE	OPERATE	RELEASE
LINE	0.050	0.008	0.003	0.008	0.003
TRUNK		0.006	OPEN	0.006	OPEN

TEST TERMINALS 3-4

TM 2087-12

Figure 105. Winding and spring terminal arrangement of Stromberg-Carlson 257-ZWEY trunk circuit relay, terminal end view.

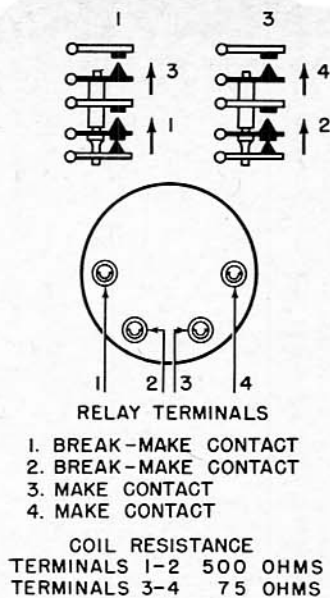

CURRENT FLOW IN AMPERES			
TEST		READJUST	
OPERATE	NON-OPERATE	OPERATE	NON-OPERATE
0.036	0.010	0.036	0.010

TEST TERMINALS 1 AND 2

TM 2087-128

Figure 107. Winding and spring terminal arrangement of Stromberg-Carlson 296-ZMN cord circuit relay.

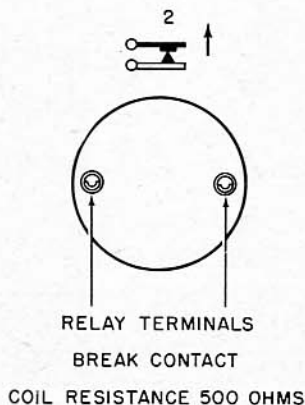

CURRENT FLOW IN AMPERES			
TEST		READJUST	
OPERATE	NON-OPERATE	OPERATE	NON-OPERATE
0.023	0.007	0.023	0.007

THIS RELAY FOR SLOW RELEASE OPERATION

TM 2087-8

Figure 106. Winding and spring terminal arrangement of Stromberg-Carlson 263-ZB trunk relay, terminal end view.

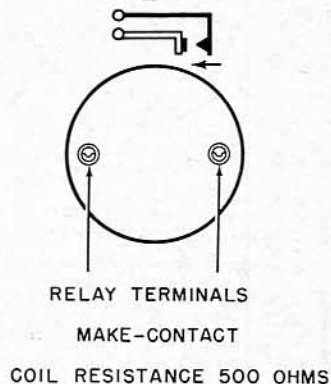

CURRENT FLOW IN AMPERES			
TEST		READJUST	
OPERATE	RELEASE	OPERATE	RELEASE
0.010	OPEN	0.010	OPEN

TM 2087-11

Figure 108. Winding and spring terminal arrangement of Stromberg-Carlson 368 X-A cord test circuit relay, terminal end view.

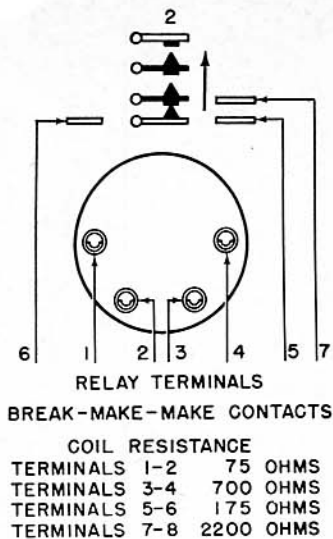

CURRENT FLOW IN AMPERES				
WINDING TERMINALS	TEST		READJUST	
	OPERATE	RELEASE	OPERATE	RELEASE
1-2	0.028	OPEN	0.028	OPEN
1-2 5-6 IN SERIES	0.070	OPEN	0.070	OPEN
3-7	0.011	OPEN	0.011	OPEN

AFTER MECHANICAL ADJUSTMENT:

1. TEST FIRST WINDING. GROUND ON TERMINAL 1. ARMATURE SPRING MUST MAKE WITH MIDDLE SPRING. DOES NOT HAVE TO LIFT OFF SEPARATOR.

2. SERIES TEST. TIE TERMINALS 1 AND 6 TOGETHER. GROUND ON TERMINAL 5. TOP CONTACT TO LIFT OFF SEPARATOR.

3. THIRD WINDING TEST. GROUND ON TERMINAL 3. TOP AND MIDDLE CONTACTS DO NOT HAVE TO MAKE. MIDDLE CONTACT DOES NOT HAVE TO LIFT FROM SEPARATOR, BUT MUST MAKE WITH ARMATURE SPRING.

TM 2087-III

Figure 109. Winding and spring terminal arrangement of Stromberg-Carlson 375-FY cord circuit relay.

## 146. Mechanical Requirements for Stromberg-Carlson Relays

Mechanical requirements for the various types of Stromberg-Carlson relays are listed below. They will be found also on sets of drawings packed with each switchboard.

Relay code No.	Spring tension (g)	Armature air gap (in.)	Residual air gap (in.)	Contact separation (in.)	
				Make	Break
192-A					
204-ZAA		0.025			
206-ZAC		.025			
257-ZWEY		.025			
263-ZB		.025			
296-ZMN		.025			
366-XA					
375-FY	(*)	.025	0.004	0.005	0.005
381-A		.025			

\*Top spring 30 grams, middle spring 30 grams, and armature spring 8 to 10 grams.

Note. For information on refinishing Switchboard SB-53( )/FTC, including inspection before refinishing, cleaning, replacement and repair, alinement of apparatus mountings, etc., refer to paragraphs 96 through 101. Instructions given in these paragraphs are equally applicable to either the Kellogg type Switchboard SB-53( )/FTC or the Stromberg-Carlson universal type 106 Switchboard SB-53( )/FTC.

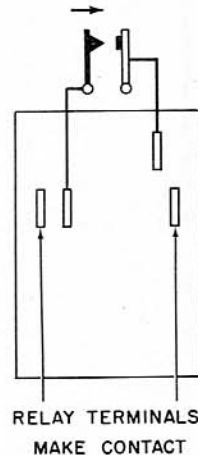

COIL RESISTANCE 1.7 OHMS

CURRENT FLOW IN AMPERES				
SOAK	TEST		READJUST	
	OPERATE	RELEASE	OPERATE	RELEASE
0.150	0.022	0.002	0.022	0.002

TM 2087-II2

Figure 110. Winding and spring terminal arrangement of Stromberg-Carlson 381-A pilot, terminal end view.



## APPENDIX I

### SHIPMENT AND STORAGE

---

#### 1. Disassembly

*a.* Remove the operator's telephone set (or sets in the case of the Stromberg-Carlson type of switchboard) and place it (or them) in the carton of unassembled parts. Place the tool roll in the same carton.

*b.* Disconnect power and grounding connections.

*c.* Unsolder all leads at points where these leads connect to terminals on the fanning boards within the switchboard. Clean the terminals and the line leads at the points where they were soldered.

*d.* Tie the cord weights within the switchboard so that they will not dangle and become twisted and tangled during shipment.

*e.* If the central office in which the switchboard has been in use is being discontinued, or the battery which has been in use with the switchboard is not to be used again immediately, store the battery as directed in TM 11-430.

#### 2. Repacking for Shipment or Limited Storage

*a.* Since Switchboard SB-53( )/FTC is usually within a fixed installation, it is likely that the original packing case is available. If the case is available, pack the switchboard for shipment or storage as described in paragraph 6 of this manual. In the event the packing case has not been saved, secure or fabricate a packing case as described in paragraph 6. Before nailing the packing case, be certain that a quantity of dessicant is included to protect the equipment against effects of moisture, in the event storage of the packing case is to be in a damp area.

*b.* Indicate, on the packing case, the date on which the switchboard is removed from service and whether at the time of its removal it was functioning properly. If it was not functioning properly, indicate what caused faulty operation and call the fact to the attention of authorized repair personnel.

*c.* Be sure that the carton of unassembled parts issued with the switchboard is kept with the packing case containing the switchboard.

## APPENDIX II

### REFERENCES AND IDENTIFICATION TABLES OF PARTS

#### Section I. REFERENCES

*Note.* For availability of items listed, check SR 310-20-3 for field manuals, training circulars, training aids, Army training programs, JANAP's, tables of organization and equipments (T/O&E's), tables of allowances (T/A's), and tables of basic allowances (T/BA's). Check FM 21-6 for technical manuals, technical bulletins, supply bulletins, modification work orders, and changes. Check Department of the Army Supply Catalog SIG 1 for Signal Corps supply catalogs.

#### 1. Technical Manuals on Associated Equipment

- TM 11-473 Central office Maintenance.  
TM 11-474 Telephone Substation Installation.  
TM 11-676 Grounding Procedure and Protective Devices.

#### 2. Painting, Preserving, and Lubrication

- TB SIG 13 Moistureproofing and Fungiproofing Signal Corps Equipment.

#### 3. Shipping Instructions

- U. S. Army Spec. No. 100-14A

Army-Navy General Specification for Packaging and Packing for Overseas Shipment.

#### 4. Decontamination

- TM 3-220 Decontamination.

#### 5. Demolition

- FM 5-25 Explosives and Demolitions.

#### 6. Other Publications

- TB SIG 25 Preventive Maintenance of Power Cords.  
TM 1-455 Electrical Fundamentals.  
TM 11-462 Signal Corps Reference Data.  
TM 38-650 Basic Maintenance Manual.

#### Section II. IDENTIFICATION TABLE OF PARTS

*Note.* The fact that an item appears in this technical manual is not sufficient basis for requisitioning it. Requisitions must cite an authorized basis, such as T/O&E's, TA's, T/BA's, SIG 6, SIG 7, SIG 8, SIG 7&8, SIG 7-S-10, SIG 10, list of allowances of expendable material or another authorized supply basis. Catalog of the Department of the Army Supply Catalog applicable to the equipment covered in this manual is listed in paragraph 1 below.

#### 1. Department of the Army Supply Catalog Reference

The following information was compiled on 26 September 1949. The appropriate catalog of the Department of the Army Supply Catalog for Telephone Switchboard SB-53( )/FTC is—

*Organizational Maintenance Allowances and Field and Depot Maintenance Stockage Guide*  
SIG 7&8 SB-53( )/FTC

For an index of available catalogs, see the latest issue of Department of the Army Supply Catalog SIG 1.

## 2. Switchboard SB-53 ( )/FTC (Kellogg Type)

Fig. and ref. symbol	Name of part and description	Function of part	Signal Corps stock No.
Fig. 47	BELL: vibrating type	Night alarm	4C201B
D, Fig. 49	BUZZER	Fuse alarm	4C1600-10
TC, RC, fig. 49	CAPACITOR, fixed: 2 mf; 160 vdcw	Reduces arcing in dial circuit	3DB2.64
A, B, fig. 39	CAPACITOR, fixed: 1 mf; 200 vdcw	Blocking capacitors in dial circuit	3DB1.132
R, fig. 38	CAPACITOR, fixed: 2-2 mf; 200 vdcw		3DB2-128
T, fig. 38	COIL, relay: 10,000 ohms	Used for testing insulation resistance in cord test circuit.	3C1098
2, fig. 39	COIL, relay: 800 ohms	Used to test resistance of line loop	3C1091-9
72-A, fig. 39	COIL, relay: 400 ohms	Adds resistance to secondary of 72-A below.	3C1091-7
Fig. 40	COIL, telephone	Induction in operator's telephone circuit.	3C872A
Fig. 48	COIL, telephone repeating	Boosts transmission in cord circuit	3C1220A
19-B, fig. 39	COIL, telephone repeating	Boosts transmission in trunk circuit	3C1219A
Ret. 8-H, fig. 39	COIL, telephone repeating	Boosts transmission in operator's telephone circuit.	3C1219B
	COIL, telephone	Retardation coil in operator's telephone circuit.	3C1608H
	CORD, switchboard: white		3E60.6
	CORD, switchboard: red		3E60.7
	CORD, switchboard: green		3E60.8
	CORD, switchboard		3E4075-5
Fig. 2	DIAL: telephone	Impulser	4B794.4-14
Fig. 9	FUSE, indicator alarm: 3 amp; blue bead.	Protection in pilot circuits	3Z2135G
Fig. 9	FUSE, indicator alarm: 1½ amp; white bead.	Protection in cord, fuse, alarm, trunk, dial, and supervisory circuits.	3Z2135B
Fig. 4	HEADBAND: operator's	Part of operator's telephone set	2B745
Fig. 4	HEAD AND CHEST SET	Part of operator's telephone set	4C9500
Fig. 2	JACK ASSEMBLY, telephone: numbered 1-10.	Line jacks	4C4426.71-11
Fig. 2	JACK ASSEMBLY, telephone: numbered 1-20.	Same as above	4C4426.71-12
Fig. 2	JACK ASSEMBLY, telephone: numbered 21-30.	Same as above	4C4426.71-13
Fig. 2	JACK ASSEMBLY, telephone: numbered 31-40.	Same as above	4C4426.71-14
Fig. 2	JACK ASSEMBLY, telephone: numbered 41-50.	Same as above	4C4426.71-15
Fig. 2	JACK ASSEMBLY, telephone: numbered 51-60.	Same as above	4C4426.71-16
Fig. 2	JACK ASSEMBLY, telephone: numbered 61-70.	Same as above	4C4426.71-17
Fig. 2	JACK ASSEMBLY, telephone: numbered 71-80.	Same as above	4C4426.71-18
Fig. 2	JACK ASSEMBLY, telephone: numbered 91-100.	Same as above	4C4426.71-19
Fig. 2	JACK ASSEMBLY, telephone: numbered 81-90.	Same as above	4C4426.71-20
Fig. 2	JACK ASSEMBLY, telephone	Trunk dial jacks	4C4427.31-1
Fig. 2	JACK, telephone	Trunk jacks	4C4432.41-1
Fig. 2	JACK, telephone		4C4432.5A
Fig. 2	JACK, telephone: 3 cond	Cord test jack	4C4428.6
Fig. 6	LAMP, incandescent: 24 v	Generator resistance lamp	4C5491-A1
Fig. 2	LAMPHOLDER	Holds cord circuit lamps	4C4439
Fig. 2	LAMPHOLDER ASSEMBLY	Holds line lamps	4C9733.4
Fig. 2	LENS, indicator light: white	Lamp caps	4C2154
Fig. 2	LENS, indicator light: red	Same as above	4C2154A

## 2. Switchboard SB-53( )/FTC (Kellogg Type)—Continued

Fig. and ref. symbol	Name of part and description	Function of part	Signal Corps stock No.
Fig. 2	LENS, indicator light: green	Same as above	4C2154W
Fig. 2	LENS, indicator light: white	Same as above	4C2009
Fig. 2	LENS, indicator light: red	Same as above	4C2009A
Fig. 2	LENS, indicator light: green	Same as above	4C2009B
	PLUG, cord: 3 cond	Cord circuit plugs	4C6706
	PLUG, switchboard		4C6782
1, 3, fig. 40	RELAY, armature	Cord circuit	4C8103.4
2, 4, fig. 40	RELAY, armature	Same as above	4C8101.4
3, fig. 49	RELAY, armature	Dial circuit	4C8137
DR, fig. 49	RELAY, armature	Operator's circuit	4C8107.3
2, fig. 48	RELAY, armature: 500 ohms	Trunk circuit	4C8137.1
3, fig. 48	RELAY, armature: 500 ohms	Same as above	4C8103.5
4, fig. 48	RELAY, armature: 1000 ohms	Same as above	4C8148.1
Figs. 41 and 42	RELAY, armature: 500 ohms	Line relay	4C8061
1, fig. 39	RELAY, armature: 500 ohms	Operator's telephone circuit	4C8146
1, fig. 48	RELAY, armature: 2000 ohms	Trunk circuit	4C8199.105
DS, fig. 49	RELAY, armature: 600 ohms	Dial circuit	4C8153
	RELAY, armature: 3.5 ohms	Pilot alarm circuit	4C8199.102
Fig. 9	RESISTOR, fixed: 50 ohms, 25 w	In connection rack	3Z6005-84
Fig. 2	SWITCH, lever	Listening switch	4C5004
Fig. 2	SWITCH, lever	Ring and ring-back switches	4C5010
Fig. 2	SWITCH, lever	Secondary cut-off switch	3Z9580-1.2
Fig. 2	SWITCH, lever	Fuse alarm and generator switches	3Z9580-1.4
Fig. 2	SWITCH, lever	Night alarm switch	4C5001
Fig. 2	SWITCH, push	Cord test switch	4C5024
Fig. 4	TRANSMITTER	Part of operator's telephone set	4C28076C
Fig. 39	VARISTOR	Lessens acoustic shock	4Z9710
Fig. 35	WEIGHT, cord	Returns cord	4C29100

## 3. Switchboard SB-53( )/FTC (Stromberg-Carlson Universal Type 106)

Fig. and ref. symbol	Name of part and description	Function of part	Signal Corps stock No.
68 and 99	BELL, vibrating type; 20 ohms DC	Night alarm	4Z424.1
69	BOARD, terminal: 2 screw, 1 solder term.	Battery and ground connection points	4C171A
92	CAPACITOR, fixed: 1 mf	Blocking capacitor in operator's circuit	3DB1.38
91	CAPACITOR, fixed: 2 mf	Blocking capacitor in cord test circuit	3DB2.39
97	CAPACITOR, fixed: 4 mf	Blocking capacitor in trunk circuit	3DB4.84
82	CAPACITOR, fixed: 1-2 mf	Blocks dc	3DB2.42
93	CAPACITOR, fixed: 2-2 mf	Block dc across repeating coil	3DB2.43
100	CAPACITOR, fixed: 1 mf and 500 ohms resistor.	Reduces arcing in dial circuit	3Z1891-13
99	COIL, relay: 15 ohms	Limits current through night alarm bell	3C615
99	COIL, relay: 50 ohms	Limits current going to night alarm bell	3Z6005-91
97	COIL, relay: 320 ohms	Completes trunk loop to called common battery office.	
B, 91	COIL, relay: 1,000 ohms	Resistance in cord test circuit	3Z6100-171
91	COIL, relay: 2 windings; 500-10,000 ohms.	Bridges 10,000 ohms across tip and ring conductors in cord test circuit.	3Z6005-83
92	COIL, telephone	Induction coil in antiside tone circuit of operator's telephone circuit.	3C947A
93	COIL, telephone	Repeating coil; transmission booster in universal cord circuit.	3C1213AL
	CORD, switchboard: white; 6 ft	For cord and dial circuits	3E61.3SC
68	CRANK, hand: generator	For generator operation	4B478

### 3. Switchboard SB-53( )/FTC (Stromberg-Carlson Universal Type 106)—Continued

Fig. and ref. symbol	Name of part and description	Function of part	Signal Corps stock No.
68	DIAL: telephone	Impulser	4B794.4-7
69	FUSE, open link: 3 amp, 110 v	Battery protection	3Z3003-2
68	GENERATOR, hand ringing: 5 magnets.	Supplies ringing current	4B905-5
70	HEAD AND CHEST SET: less plug	Operator's telephone set	4C9500
68	JACK, telephone: 4 cond	Operator's telephone jack	4C4560.93
68	JACK, telephone	Cord test jack	4C4561.56
68	JACK ASSEMBLY, telephone: 10 per strip.	Line jacks	4C4561.37-1
68	JACK ASSEMBLY, telephone: 10 per strip.	Trunk line jacks	4C4561.342
68	JACK ASSEMBLY, telephone: 10 per strip.	Trunk dial jacks	4C4561.63-1
68	LAMP: switchboard; 24 v	Signal for line, trunk, and cord circuits	4C5492U
84	LAMP: 115 v; 40 w	Resistance lamp	6Z6815-15
68	LAMPHOLDER: telephone sb	Socket for pilot signal lamp	4C9775-9
68	LAMPHOLDER: telephone sb	Sockets for supervisory signal lamps	4C9774
68	LAMPHOLDER ASSEMBLY: 10 per strip.	Sockets for line and trunks signal lamps.	4C9772.180
68	LENS, indicator light: white	Caps for pilot lamps	4C2423A
68	LENS, indicator light: red	Same as above	4C2423B
68	LENS, indicator light: white	Caps for line lamps	4C2427A
68	LENS, indicator light: red	Caps for cord supervisory lamps	4C2431B
	PLUG: sb		4C7040
	PLUG: cord; 3 cond		4C7053X
91	RELAY, armature: 500 ohms AC	In cord test circuit	4C8666XA
96	RELAY, armature: 1.7 ohms	Pilot circuit	4C8561A
94 and 95	RELAY, armature: 100-670 ohms	Line circuit	4C8522A
93	RELAY, armature: 75-175-620-200 ohms.	In cord circuit	4C8603.75ZFY
97	RELAY, armature: 250-670 ohms	In trunk circuit	4C85872W-EY
97	RELAY, armature: 500 ohms	Same as above	4C8536Z-AC
97	RELAY, armature: 500 ohms, slow release.	Same as above	4C8593ZB
93	RELAY, armature: 500-75 ohms	In cord circuit	4C8602.96ZMN
92	RELAY, armature: 100 ohms	In operator's circuit	4C8534ZAA
	RESISTOR, fixed: 2200 ohms	Bypass	3Z6220-32
	RESISTOR, fixed: 47,000 ohms	Same as above	3Z6647-35
	RINGER, telephone	Buzzer	4B3628H
68	SWITCH, lever: cam type	Controls talking and ringing	4C5063.42KX
68	SWITCH, lever	Controls ringing	4C5063.41A
68	SWITCH, lever: push button, non-locking.	Cord test control	3Z9580-4.3
68	SWITCH, push button: locking	Night alarm, battery cut-off and generator switches.	4C5061.19
92	VARISTOR: receiver shunting	Lessens acoustic shock	4Z9710
35	WEIGHT, cord	Returns cord	4C29100



## APPENDIX III

### DEMOLITION TO PREVENT ENEMY USE

---

#### 1. General

The demolition procedures outlined in paragraphs 2 and 3 below will be used to prevent the enemy from using or salvaging this equipment. Demolition of the equipment will be accomplished *only* upon order of the commander.

#### 2. Methods of Destruction

*a. Smash.* Use sledges, axes, handaxes, pickaxes, hammers, crowbars, heavy tools.

*b. Cut.* Use axes, handaxes, machetes.

*c. Burn.* Use gasoline, kerosene, oil, flame throwers, and incendiary grenades.

*d. Explosives.* Use firearms, grenades, TNT.

*e. Other.* Use anything immediately available for destruction of this equipment.

*f. Disposal.* Bury in slit trenches, fox holes, other holes. Throw in streams. Scatter.

#### 3. Destruction of Components

*a. Smash* relays, resistors, capacitors, switches, nameplates, and other identifying marks.

*b. Cut* all wiring and cables.

*c. Burn* technical manuals, wiring, and cables.

*d. Bend* framework and panels, tools, etc.

*e. Bury or scatter* any or all of the above pieces after smashing, cutting, bending, or breaking.

*f. Destroy everything.*

## INDEX

	<i>Paragraph</i>	<i>Page</i>		<i>Paragraph</i>	<i>Page</i>
AF Form 54 (Unsatisfactory Report)...	2a (3)	1	Dimensions:		
Adjustment:			Switchboard SB-53( )/FTC (Kellogg type).....	5	2
Apparatus.....	87, 144	51, 88	Switchboard SB-53( )/FTC (Stromberg-Carlson type).....	103	60
Kellogg type relays.....	94d	56	Disassembly for shipment and storage.....	App. I	91
Operator's telephone set.....	26	15	Equipment:		
Stromberg-Carlson type relays.....	145	88	Application.....	8, 106	7, 64
Alarms:			Connections.....	11b, 108	8, 65
Audible, repair.....	95	57	Connections, possible with either type of switchboard.....	8	7
Fuse alarm, preoperational test.....	25	15	Performance checklist.....	30	17
Night alarm, preoperational test.....	22c	15	Power and protection.....	21a	14
Alinement and apparatus mountings.....	101	59	Service upon receipt.....	9	8
Analysis of trouble location.....	70	37	Test and repair.....	60	32
Apparatus:			Test, used but not furnished.....	62	32
Adjustments and requirements.....	87, 144	51, 88	Shipment, data for export packaging.....	6	2
Mountings and alinement.....	101	59	Facilities provided by switchboards.....	8a, 106	7, 64
Appendixes.....	3	1	Field and base maintenance instructions, scope.....	45	22
Application of Switchboard SB-53( )/FTC.....	8	7	Final testing, preparation.....	73	38
Arrangement:			Form:		
Fuses in Kellogg type switchboard.....	11b (7)	11	AAF 54.....	2a(3)	1
Fuses in Stromberg-Carlson type switchboard.....	108f	67	NME 6.....	2a(1)	1
Battery:			DA AGO 468.....	2a(2)	1
Type used.....	4d	2	Forms and records.....	2	1
Voltage test.....	22a	15	Frequency converter.....	4c	2
Battery cut-off switch, description of.....	112	69	Functions of switchboards.....	1c	1
Boards, terminal.....	11b (3), 108b	10, 65	Fuse:		
Circuits, theory of operation:			Alarm test.....	25	15
Cord test.....	53, 124	29, 75	Arrangement on Kellogg type switchboard.....	11b(7)	11
Dial and dial cord.....	51, 122	27, 75	Arrangement on Stromberg-Carlson type switchboard.....	108f	67
Fuse alarm.....	58	31	Repair.....	69	37
Fuse pilot.....	57	31	Gas conditions, operation under.....	32	18
Generator.....	52, 123	28, 75	Generator, hand:		
Ground.....	59, 129	32, 78	Adjustment and repair.....	90	51
Line pilot.....	54, 125	30, 77	Switch, use.....	16, 110	13, 69
Night alarm.....	56, 127	30, 77	Ground connections.....	9	8
Operator's telephone.....	50, 121	27, 75	Grounding.....	11b (11)	11
Supervisory pilot.....	55, 126	30, 77	Hand generator, adjustment and repair.....	90	51
Universal cord.....	49, 120	23, 72	Improper shipment form.....	2a (1)	1
Universal line.....	47, 118	22, 71	Individual circuit arrangements, differences in.....	1c	1
Universal trunk.....	48, 119	23, 71	Inspection:		
Demolition to prevent enemy use.....	App. III	96	Before refinishing.....	96	58
Description:			Before repairs.....	65	35
Preventive maintenance.....	41	20	Visual, at time of receipt of equipment.....	10	8
Switchboard SB-53( )/FTC (Kellogg type).....	7	3			
Switchboard SB-63( )/FTC (Stromberg-Carlson type).....	102	60			
Desert maintenance.....	38	20			
Dial:					
And dial cord circuits.....	51, 86,	27, 49,			
Function.....	122, 142	75, 87			
Differences in circuits and mechanical details.....	20	14			
	1c	1			

	Paragraph	Page		Paragraph	Page
Installation:			Power:		
Switchboard SB-53( )/FTC (Kellogg type).....	11	8	And protective equipment.....	21a	14
Switchboard SB-53( )/FTC (Stromberg-Carlson type).....	108	65	Points of connection for 24-v dc... 11b, 108g		11, 67
Instructions, field and base maintenance, scope and application.....	45	22	Requirements for test equipment.....	64	35
Interchangeability of switchboards.....	1b	1	Ring generator connections.....	11b (11)	11
Kellogg type 561-A line relay.....	11b (14)	11	Preoperational tests.....	22, 113	15, 69
Lamps, supervisory, checking.....	24	15	Prerepair procedures.....	130	78
Installation.....	11b (9)	11	Preventive maintenance:		
Line:			Checklist.....	43	21
Jacks and line lamps, adjustment.....	88	51	Fuses.....	42g	21
Lamps and line pilot lamps, checking.....	23	15	Lamps.....	42f	21
Leads, soldering.....	12	12	Meaning.....	40	20
Lines, longer-than-normal.....	106c	64	Night alarm.....	42h	21
Listening switches, use.....	14	13	Operator's telephone sets.....	42i	21
Localization in trouble location.....	72	37	Switchboard exterior.....	42b	20
Locating:			Switchboard interior.....	42c	21
Switchboard.....	11a	8	Switches.....	42e	21
Relays in Kellogg type switchboard.....	7b	5	Rectifier for charging batteries.....	4e	2
Relays in Stromberg-Carlson type switchboard.....	105b	64	Refinishing:		
Magneto:			Cleaning, before.....	53	58
Hand crank, method of attaching..... 11b (10)	11	11	General.....	96	58
Ringing.....	31	18	Inspection, before.....	97	58
Maintenance:			Relays:		
Desert.....	38	20	Adjustment of Kellogg type.....	94d	54
Materials required.....	3	!	Adjustment of Stromberg-Carlson type.....	145	88
Meaning of preventive.....	40	20	Cover designations.....	69b	37
Tools required.....	34, 115	19, 70	Location in Kellogg switchboard... 7b		5
Materials:			Location in Stromberg-Carlson type switchboard.....	105b	64
Maintenance.....	33	19	Removal of jack strips.....	88	51
Necessary for test and repair.....	61	32	Repair:		
Mechanical details, differences in switchboards.....	1c	1	And replacement of mutilated parts.....	99b	59
Mechanical requirements:			Audible alarm.....	95	57
Kellogg type relays.....	94e	57	Cords and plug.....	91	51
Stromberg-Carlson type relays.....	146	90	Dial.....	93	51
Microphones T-45 and T-30.....	32	18	Fuse.....	69	37
Multimeter TS-380/U.....	62d	34	References.....	46	22
Night alarm:			Replacement:		
Switch, use.....	18	13	And repair of broken and mutilated parts.....	99b	59
Test.....	22c	15	Dial.....	93	51
NME Form 6.....	2a (1)	1	Report:		
Operation under gas conditions.....	32	18	AF Form 54 (Unsatisfactory Report).....	2a (3)	1
Operator's telephone sets:			NME Form 6 (Report of Damaged or Improper Shipment).....	2a (1)	1
Adjustment.....	26	15	DA AGO Form 468 (Unsatisfactory Equipment Report).....	2a (2)	1
Kellogg type.....	7c	5	Requirements:		
Stromberg-Carlson type.....	105c	64	Adjustment of apparatus.....	87	51
Packaging data for export shipment... 6, 104	2, 60	2, 60	Mechanical, of Kellogg type relays.....	94e	57
Performance, equipment.....	29, 30	17	Mechanical, of Stromberg-Carlson type relays.....	146	90
Pertinent repair information.....	66	36	Rewiring:		
Pilot lamps, checking.....	23	15	Kellogg type line relay.....	11b (14)	11
Plugs, replacement and repair.....	91	51	Stromberg-Carlson type relays... 108 k,		67
Possible connections for switchboards... 8	7	7		l, m, n, o	

	<i>Paragraph</i>	<i>Page</i>		<i>Paragraph</i>	<i>Page</i>
Ringling:			Test—Continued		
Magneto.....	31	18	Fuse alarm.....	25	15
Current test.....	22b	15	Jacks, use.....	19	13
Switches, use.....	14b	13	Night alarm.....	22c	15
Scope of manual.....	1	1	Power requirements:		
Sectionalization in trouble location.....	71	37	Switchboard.....	63	35
Service upon receipt of equipment.....	9, 107	8, 65	Test equipment.....	64	35
Set, operator's telephone.....	4c, 105c	2, 64	Preoperational.....	22	15
Shipment and storage.....	App. I	91	Ringing current.....	22b, 75c	15, 38
Shooting, trouble.....	44, 117	21, 70	Set I-49.....	62a	32
Siting.....	10a	8	Set I-181.....	62b	32
Soldering line leads.....	12	12	Set TS-190/U.....	62c	32
Supervisory lamps, checking.....	24	15	Set-up for switchboard.....	75	38
Switchboard:			Trouble location (by circuits):		
Application.....	8, 106	5, 64	Battery switch cut-off.....	143	87
Check and visual inspection.....	10c	8	Cord test.....	76, 134	38, 78
Connections, possible.....	8	5	Dial and dial cord.....	86, 142	49, 87
Controls:			Fuse alarm pilot.....	83	46
Kellogg type.....	13-20	13	Line pilot.....	80, 138	45, 84
Stromberg-Carlson type.....	109-113	69	Night alarm.....	82, 141	46, 86
Description of Stromberg-Carlson type.....	102, 105	60	Operator's telephone.....	77, 135	40, 80
Facilities provided.....	4b, 106	2, 64	Supervisory pilot.....	81, 140	46, 86
Grounding.....	11b	8	Universal cord.....	78, 136	41, 80
Installation.....	11, 108	8, 65	Universal line.....	79, 137	44, 83
Interchangeability.....	1b	1	Universal trunk.....	85, 139	48, 85
Locating.....	11a	8	Trouble shooting.....	44, 117	21, 70
Operator's telephone set (Kellogg type).....	7c, 105c	5, 64	Theory of operation. (See Circuits.)		
Power:			Tropical maintenance.....	36	20
Requirements for testing.....	63	35	Tools required for:		
Supply.....	4d	2	Kellogg type switchboard.....	34	19
Removing from crate.....	10a	8	Stromberg-Carlson type switchboard.....	115	70
Unpacking.....	10b	8	Unpacking and visual inspection.....	10	8
Weights and dimensions.....	5, 103	2, 60	Unsatisfactory equipment report on DA Form 468.....	2a (2)	1
Switches:			Unsatisfactory report on AF Form 54.....	2a (3)	1
Alinement.....	101b	59	Use:		
Battery cut-off.....	112	69	Cord circuit.....	21b	15
Cord circuit.....	14, 109	13, 69	Secondary cut-off switch.....	15	13
Cord test, use.....	19, 113	13, 69	Voltage test.....	22a	15
Fuse alarm.....	17	13	Weatherproofing.....	35, 116	19, 70
Generator.....	16, 110	13, 69	Weights:		
Listening, use.....	14	13	And dimensions of switchboards.....	5, 103	2, 60
Ringing, use.....	14	13	Cord.....	68	37
Secondary cut-off, use.....	15	13	Winter maintenance.....	37	20
Techniques, preventive maintenance.....	41	20	Wire pairs, method of connection.....	11b, 108	8, 65
Terminals, soldering line leads to.....	12	12	Wiring:		
Test:			Changes for Kellogg 561-A line relay.....	11b (14)	11
And repair equipment.....	60	32	Changes for Stromberg-Carlson.....	108l, m, n, o	67
Equipment used but not furnished.....	62	32	Terminal lugs repair.....	67	36
For battery.....	22, 75a	15, 38			
For ground.....	75b	38			

Technical Manual

SWITCHBOARDS SB-53/FTC AND SB-53A/FTC

CHANGES  
No. 1

TM 11-2087, 19 January 1950, is changed as follows:

The title of the manual is changed to read:

SWITCHBOARDS SB-53/FTC and SB-53A/FTC

Switchboard SB-53( )/FTC is changed to Switchboard SB-53/FTC throughout the manual.

1. Scope

a. These instructions are \* \* \* type 106 switchboard. They also apply to Switchboard SB-53A/FTC which is similar to Switchboard SB-53/FTC Stromberg-Carlson type, except as noted herein.

\* \* \* \* \*

103. Weight and Dimensions

a. Data given below \* \* \* ready for installation.

Unit	Height (in.)	Width (in.)	Depth (in.)	Weight (lb.)	Volume (cu. ft.)
* Switchboard SB-53A/FTC	51	25	34-13/16	525	25.78

\* \* \* \* \*

109. Cord Circuit Switches

(fig. 75)

\* \* \* \* \*

b. Ring-Back Switches. The 15 switches in the rear row are one-position, nonlocking, lever-type switches used to ring back a calling line when moved to the forward position.

115.1. Tools Required for Switchboard SB-53A/FTC  
(Added)

Tools are needed for organizational maintenance of this switchboard. They are supplied in a canvas tool roll (fig. 76.1) and consist of the following tools:

- No. 44 Screw driver.
- No. 45 Screw driver.
- No. 7 Spring bender.

DEPARTMENT OF THE ARMY  
WASHINGTON 25, D. C., 21 September 1953

- No. 52 Screw driver.
- No. 2 Socket wrench.
- No. 36 Spring bender.
- No. 268 Spring bender.
- No. 70 Lamp cap extractor.
- No. 69 Jack sleeve remover.
- No. 553-A Lamp extractor.
- No. 42 Screw driver.
- No. 24 Socket wrench and screw driver.
- No. 61 Burnisher.

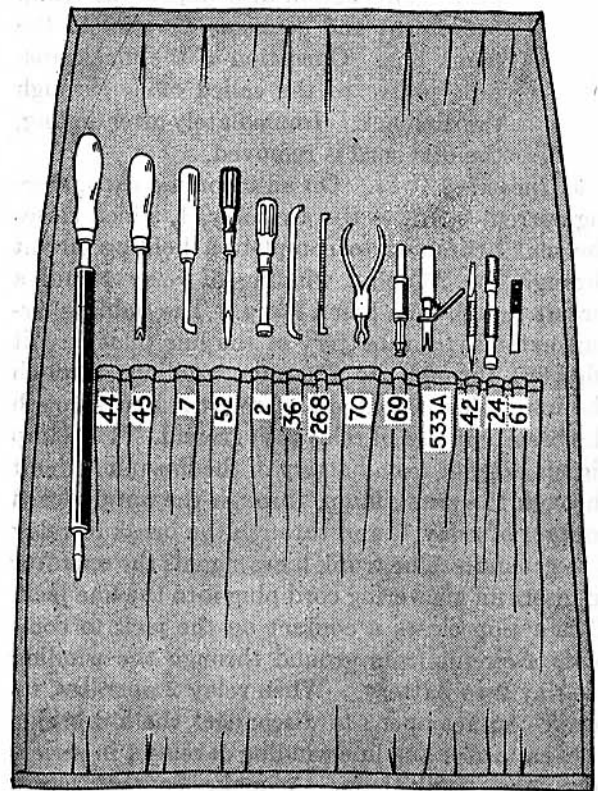

TM 2087-C1-2

Figure 76.1 (Added). Tools supplied with Switchboard SB-53A/FTC.

119.1. Universal Trunk Circuit of Switchboard SB-53A/FTC  
(fig. 79.1) (Added)

- a. Outgoing Calls.
  - (1) To common battery exchange. Insertion of a cord plug into a trunk line jack causes



a make contact of the line jack to complete the circuit to ground for the operation of relay 2. A make contact of relay 2 completes the trunk loop through windings (8-7 and 6-5 in series) of the repeating coil to signal the distant operator.

- (2) *To magneto exchange.* The trunk circuit to a magneto exchange functions as described for the common battery exchange, except that the operator must ring to signal the distant office.
- (3) *To dial exchange.* To call a dial exchange, a calling cord plug is inserted into a trunk line jack and the dial cord plug into the dial jack. Insertion of the dial cord plug opens the dial jack break contact. This action disconnects the trunk equipment and connects the dial to the trunk line. Operation of the dial transmits pulses to the called office through the dial jack. Immediately after dialing, the dial cord is removed.

*b. Incoming Calls.* On all incoming calls, ringing current operates the a-c relay, 1, which closes the make contacts to complete a holding circuit through the 250-ohm winding of relay 1 and a circuit to light the trunk lamp. The holding circuit extends from battery of the line pilot circuit (fig. 86) through its 250-ohm winding, through the inner closed contacts of relay 1, and through the break contact of relay 3 to ground. The lamp circuit extends from battery of the line pilot circuit through the trunk lamp, through the outer closed contact of relay 1, and through the break of relay 3 to ground. The trunk lamp signals the operator to insert an answering cord plug into the line jack. This action closes a contact on the jack to complete a circuit from ground through the winding of relay 2 to battery. When relay 2 operates, its break contact opens to disconnect the a-c bridge (1- $\mu$ f capacitor and line winding of relay 1 in series) from the trunk loop. A make contact closes instantly to reconnect a d-c bridge (windings 8-7 and 6-5 of the repeating coil in series) across the trunk loop. The d-c bridge so connected completes a circuit for the operation of an answering signal at the calling office. A second make contact of relay 2 closes a circuit for the operation of relay 3. When relay 3 operates, its break contact opens the trunk lamp circuit and also the holding circuit of relay 1. This action extinguishes the trunk lamp and restores relay 1 to normal.

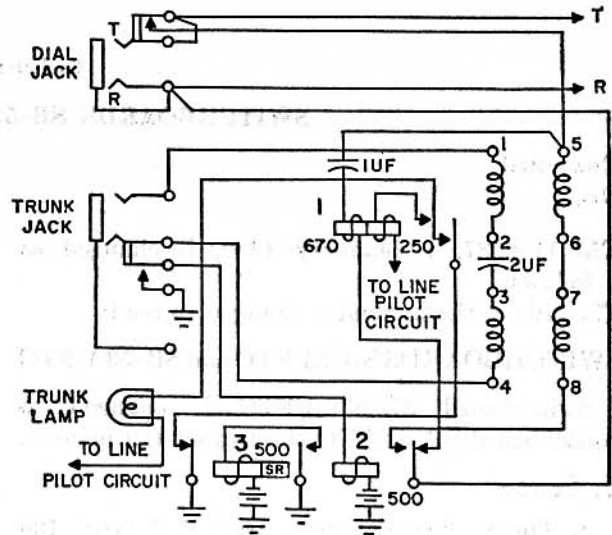

NOTE  
UNLESS OTHERWISE SHOWN,  
RELAY WINDINGS ARE IN OHMS. TM 2087-C1-3

Figure 79.1 (Added) Switchboard SB-53A/FTC, universal trunk circuit, schematic.

## 120. Universal Cord Circuit (figs. 81 and 81.1)

- \* \* \* \* \*
- b. Magneto to Magneto Connections.*
- \* \* \* \* \*

- (2) When the operator is signaled on recall or on completion of conversation in the case of the SB-53/FTC (fig. 81), ringing current passes through the 620-ohm winding in series with the 2,200-ohm, noninductive winding of relay 3 for the calling telephone, and relay 4 for the called telephone; in the case of the SB-53A/FTC (fig. 81.1), ringing current passes through the 650-ohm winding in series with the 2,200-ohm, noninductive winding of relay 3 for the calling telephone, and relay 4 for the called telephone. The ringing current \* \* \* circuit to ground.

## 136. Cord Circuit (fig. 93)

Perform these tests on both ends of cord circuit.

\* \* \* \* \*

- b. Magneto Operation of Cord Circuit.* Only those features \* \* \* with magneto telephones.

- (1) Answer cord recall test.  
\* \* \* \* \*
- (b) Operating the magneto cord test cir-

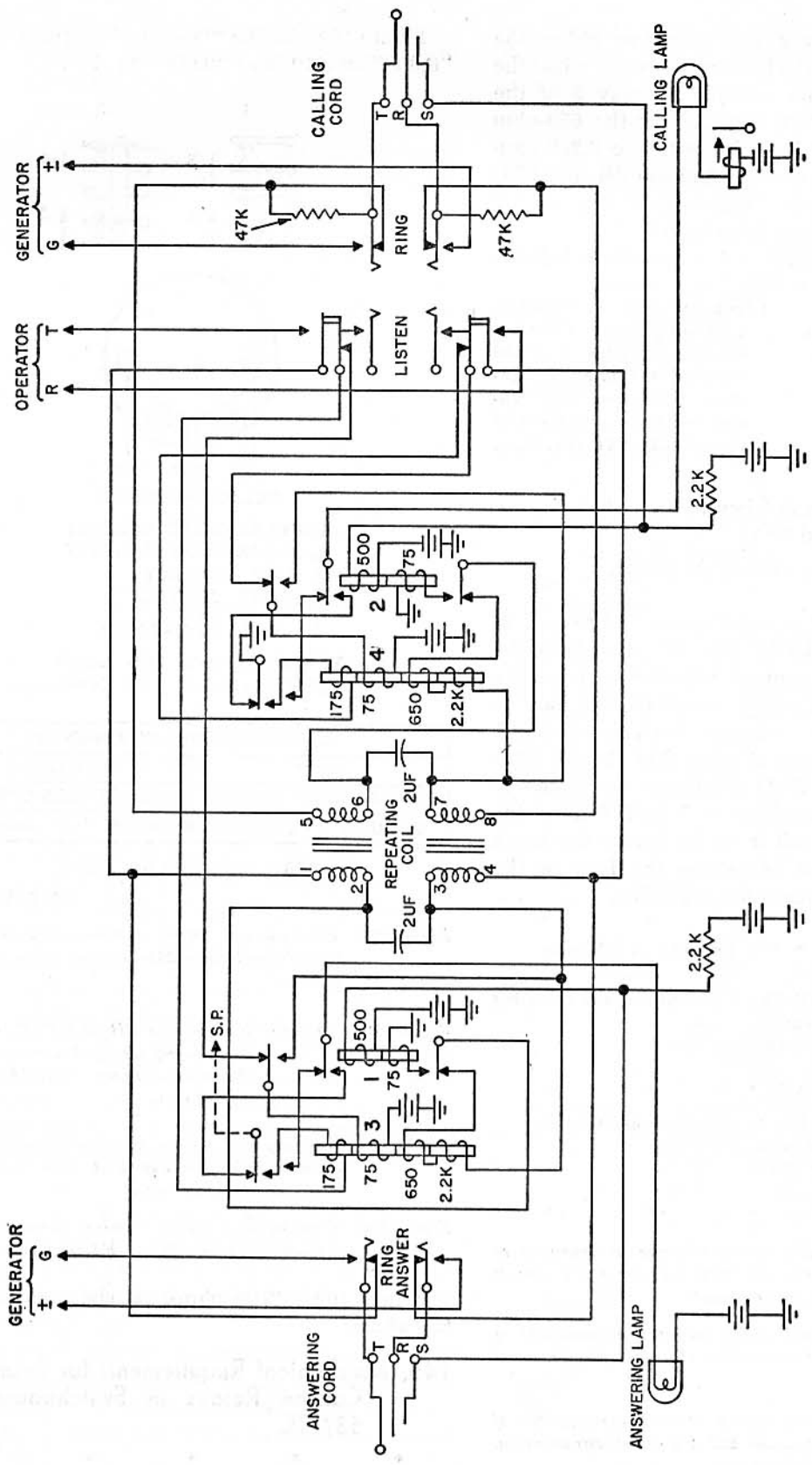

**NOTE:**  
UNLESS OTHERWISE SHOWN;  
RELAY WINDINGS ARE IN OHMS.

Figure 81.1 (Added) Switchboard SB-53A/FTC, universal cord circuit, schematic.

cuit test switch energizes either the 620-ohm winding in series with the 2,200-ohm winding of relay 3 of the SB-53/FTC (fig. 93), or the 650-ohm winding in series with the 2,200-ohm winding of relay 3 of the SB-53A/FTC (fig. 81.1). This causes relay \* \* \* supervisory lamp lights.

(c) If the answer \* \* \* trouble as follows:

Possible trouble	Analysis
Relay 3 does not operate.	Check for open in 620-ohm, 2,200-ohm, and 175-ohm windings of relay 3 of the SB-53/FTC (fig. 93) or 650-ohm, 2,200-ohm, and 175-ohm windings of relay 3 of the SB-53A/FTC (fig. 81.1).

\* \* \* \* \*

### 139. Universal Trunk Circuit (figs. 97 and 79.1)

a. Call to Common Battery Exchange.

\* \* \* \* \*

(2) On closing, a make contact of relay 2 of the SB-53/FTC (fig. 97) completes the circuit to connect inductor 4 across the trunk line which completes the loop to the called common battery office. A make contact of relay 2 of the SB-53A/FTC (fig. 79.1) completes the circuit to connect windings 8-7 and 6-5 of the repeating coil in series across the trunk line, which completes the loop to the called common battery office.

\* \* \* \* \*

(4) If the test \* \* \* trouble as follows:

Possible trouble	Analysis
Inductor 4 winding (SB-53/FTC) open or repeating coil winding (SB-53A/FTC) open.	Check inductor or repeating coil.

\* \* \* \* \*

Open wiring to inductor 4 (SB-53/FTC or open wiring to repeating coil (SB-53A/FTC)).

\* \* \* \* \*

Figure 103. Winding and spring terminal arrangement of Stromberg-Carlson 204-AA operator's circuit relay terminal end view.

Figure 104. Winding and spring terminal arrangement of Stromberg-Carlson 206-AC trunk relay, terminal end view.

Figure 105. Winding and spring terminal arrangement of Stromberg-Carlson 257-FY trunk circuit relay, terminal end view.

Figure 105. In the "Operate" columns, change "0.008" to .010, and "0.006" to .008.

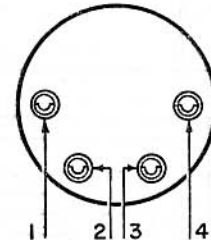
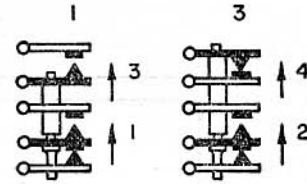

RELAY TERMINALS

- 1. BREAK-MAKE CONTACT
- 2. BREAK-MAKE CONTACT
- 3. MAKE CONTACT
- 4. BREAK CONTACT

COIL RESISTANCE

TERMINALS 1-2 500 OHMS  
TERMINALS 3-4 75 OHMS

CURRENT FLOW IN AMPERES			
TEST		READJUST	
OPERATE	NON-OPERATE	OPERATE	NON-OPERATE
0.036	0.010	0.036	0.010

TEST TERMINALS 1 AND 2

TM 2087-CI-8

Figure 106. Winding and spring terminal arrangement of Stromberg-Carlson 263-B trunk relay, terminal end view.

Figure 107.1 (Added) Switchboard SB-53A/FTC, winding and spring terminal arrangement of Stromberg-Carlson 269-MN, cord circuit relay.

Figure 108. Winding and spring terminal arrangement of Stromberg-Carlson 366 X-A cord test circuit relay, terminal end view.

Figure 109. Winding and spring terminal arrangement of Stromberg-Carlson 375-1-FY cord circuit relay.

Figure 109. "700 ohms" is changed to read: 650 ohms.

### 146. Mechanical Requirements for Stromberg-Carlson Relays in Switchboard SB-53/FTC

\* \* \* \* \*

## 147. Mechanical Requirements for Stromberg-Carlson Relays in Switchboard SB-53A/FTC (Added)

Mechanical requirements for the various types of relays used in Switchboard SB-53A/FTC are listed below.

Relay code No.	Spring tension (g)	Armature air gap (in.)	Residual air gap (in.)	Contact separation (in.)	
				Make	Break
192-A	-----	-----	-----	-----	-----
204-AA	-----	.025	-----	-----	-----
206-AC	-----	.025	-----	-----	-----
257-EY	-----	.025	-----	-----	-----
263-B	-----	.025	-----	-----	-----
296-MN	-----	.025	-----	-----	-----
366X-A	-----	-----	-----	-----	-----
*375-1-FY	-----	.025	.003	.005	.005
381-A	-----	.025	-----	-----	-----

\*Top spring 30 grams, middle spring 30 grams, and armature spring approximately 20 grams.

Figure 110. Winding and spring terminal arrangement of Stromberg-Carlson 381-A pilot relay, terminal end view.

## 148. Jack Sleeve Replacement (fig. 111) (Added)

Switchboard SB-53A/FTC is equipped with jack strips that have removable jack sleeves. A worn or damaged jack sleeve may be replaced by the use of a No. 69 tool as outlined below.

a. Hold the tool by its body and turn the rod counterclockwise until the diameter of the chuck is decreased sufficiently to permit insertion of the chuck end into the jack sleeve to be replaced.

b. Insert the chuck end of the tool into the jack sleeve as far as the shoulder of the chuck permits. Then turn the rod in a clockwise direction until the chuck is seated firmly in the sleeve of the jack.

c. Turn the body of the tool in a counterclockwise direction until the threaded end of the jack sleeve is disengaged.

d. Pull the tool forward and free the jack sleeve by turning the rod counterclockwise.

e. Place a new jack sleeve on the chuck and turn the rod in a clockwise direction until the sleeve fits tightly on the chuck.

f. Insert the sleeve equipped end of the tool into the vacant sleeve opening as far as possible and turn the body of the tool in a clockwise direction until the threaded end of the new sleeve is seated firmly.

TAGO 1038A

g. Then turn the rod counterclockwise until the tool is loose and thus permits its removal from the jack sleeve.

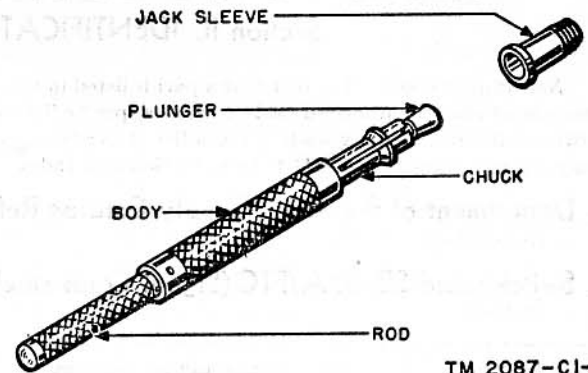

TM 2087-CI-7

Figure 111 (Added) Switchboard SB-53A/FTC, jack sleeve tool.

## 149. Hand Generator (fig. 112) (Added)

The hand generator may be removed for adjustment or repair. To remove the generator, first disconnect the wires, and then unscrew the crank by turning in a counterclockwise direction while its extension shaft is held stationary. Then turn the extension shaft in a counterclockwise direction to free it from the generator. By the removal of the four screws that secure the generator to the cord shelf, the generator is freed.

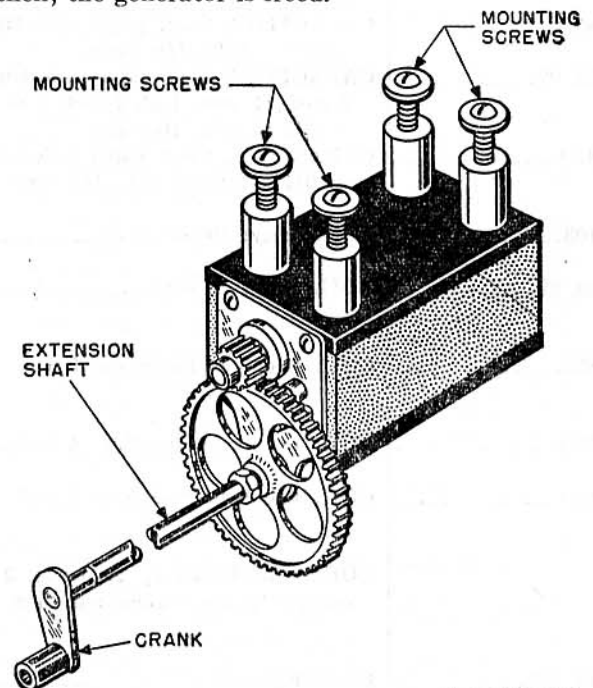

TM 2087-CI-1

Figure 112 (Added) Hand generator supplied with Switchboard SB-53A/FTC, overall view.

## APPENDIX II

# REFERENCES AND IDENTIFICATION TABLES OF PARTS

### Section II. IDENTIFICATION TABLE OF PARTS

*Note* (Superseded). The fact that a part is listed in this table is not sufficient basis for requisitioning the item. Requisitions must cite an authorized basis, such as a specific T/O & E, T/A, SIG 7 & 8, list of allowances of expendable material, or other authorized supply basis. For a list of available supply manuals in the Signal portion of the Department of the Army Supply Manual, see SIG 1, Introduction and Index.

#### 1. Department of the Army Supply Catalog Reference

(Rescinded)

#### 4. Switchboard SB-53A/FTC (Signal Corps stock No. 4C12100-52)

(Added)

Fig. No.	Name of part and description	Function of part	Signal Corps stock No.
76, 76.1-----	ADJUSTER, spring: St Carl tool No. 36---	For adjusting relay springs-----	6R40636
76, 76.1-----	ADJUSTER, spring: St Carl tool No. 7-----	For adjusting relay springs-----	6R40607
76, 76.1-----	ADJUSTER, spring: WECo tool No. 268---	For adjusting relay springs-----	6R41068
88, 99-----	BELL, electrical: vibrating type; 3" gong; 24 v d-c, 120 ma.	Used in night alarm circuit-----	4Z424.1
76, 76.1-----	BURNISHER, contact: hand; St Carl tool No. 61.	For cleaning relay and switch contacts.	6R40661
84-----	BUZZER: vibrating type; 90-110 v d-c; 16-20 cps.	Used in generator circuit-----	4B3628H
82, 92-----	CAPACITOR, fixed: paper dielectric; 1 $\mu$ f +20% -10%; 160 vdcw.	Prevents flow of direct current through receiver of operator's headset.	3DB1-451
83-----	CAPACITOR, fixed: paper dielectric; 2 sect., 1 $\mu$ f +20% -10% ea sect.; 160 vdcw.	Used with 500-ohm resistor to prevent arcing when contacts of dial open.	3DB1-450
88-----	CAPACITOR, fixed: paper dielectric; 2 $\mu$ f +20% -10%; 160 vdcw.	Prevents arcing when contacts of d-c alarm bell open.	3DB2-311
82, 92-----	CAPACITOR, fixed: paper dielectric; 3 $\mu$ f; 2 sect.; 1 sect. 1 $\mu$ f, 1 sect. 2 $\mu$ f +20% -10% ea sect.; 160 vdcw.	Raises level of voice currents in transmitter circuits.	3DB2-310
81.1-----	CAPACITOR, fixed: paper dielectric; 2 $\mu$ f +20% -10% ea sect.; 160 vdcw.	Provides transmission path through windings of repeating coil.	3DB2-309
103-----	COIL, relay: 100 ohms dc-----	Used for replacement of defective coil on 204-AA relay.	361106
88, 99-----	COIL, relay: 15 ohms-----	Prevents interference with adja- cent radio equipment when contacts of d-c alarm bell open.	3C615
82-----	COIL, telephone induction: 3 wnd-----	Used to boost transmission and prevent sidetone in receiver conversation.	3C947A
79.1-----	COIL, telephone repeating: 4 wnd-----	Used to isolate cord circuit from trunk during dialing period.	3C1211A
81.1-----	COIL, telephone repeating: 4 wnd-----	Used to isolate answering super- visory circuit from the calling supervisory circuit.	3C1213AL
	CORD ASSEMBLY, electrical: 3 tinsel cord; 6' lg; color-coded red, blue, white.	Used to complete connection be- tween cord circuit and line jack, and between dial cord circuit and dial jack of trunk.	3E61.3SC
84, 111-----	CRANK, hand-----	Used to rotate armature of hand generator.	4B478
83, 100-----	DIAL, telephone: delayed impulse type----	Transmits dial pulses-----	4B794.4-10
79.1, 112-----	EXTRACTOR, jack sleeve: St Carl tool No. 69.	Used to remove jack sleeves-----	6Q36902



Fig. No.	Name of part and description	Function of part	Signal Corps stock No.
76, 76.1-----	EXTRACTOR, lamp: WEC Co No. 533-A	Used to remove switchboard lamps.	6R41353A
76.1	EXTRACTOR, lamp cap: St Carl tool No. 70.	Used to remove lamp caps-----	6Q36920-8
84, 111	FUSE, open link: 3 amp-----	Protects circuit wiring-----	3Z3003-2
70	GENERATOR, ringing: hand-----	Supplies ringing current-----	4B905-7
68, 79.1, 80	HEADSET-CHEST SET, electrical: 280 ohms impedance.	Used to transmit and receive conversation.	4B2155
	JACK ASSEMBLY, telephone: 10 jacks mtd on black phenolic strip; for 3 cond plug.	Terminates leads of 10 trunk circuits in switchboard to permit dialing when required.	4C4561.63-1
	JACK ASSEMBLY, telephone: 10 jacks mtd on black phenolic strip; for 3 cond plug.	Terminates telephone leads of 10 trunks in switchboard.	4C4561.342
	JACK ASSEMBLY, telephone: 10 jacks mtd on black phenolic strip; for 2 or 3 cond plug.	Terminates 10 line circuits in switchboard.	4C4561.37-1
85, 91	JACK, telephone: for 3 cond plug-----	Terminates cord test circuit in switchboard.	4C4561.56
68-----	JACK, telephone: for 4 cond plug-----	Terminates operator's telephone circuit in switchboard.	4C4560-93
69, 84-----	LAMP, incandescent: 115 v; 40 w-----	Limits current in the event the ringing leads are short-circuited at the switchboard.	6Z6815-15
68-----	LAMP, incandescent: 24 v, .035 to .050: lamp slide base.	Signal for line, trunk, and cord circuits.	4C4591-A1
	LAMPHOLDER, telephone-----	Socket for line pilot lamp-----	4C9775-9
	LAMPHOLDER, telephone: med screw type.	Socket for resistance lamp-----	6Z8355-29
	LAMPHOLDER, telephone-----	Socket for cord supervisory or cord test.	4C9774
	LAMPHOLDER ASSEMBLY: 10 per strip.	Sockets for 10 line or 10 trunk signal lamps.	4C9772.180
	LENS, indicator light: red-----	Cap for cord supervisory or cord test lamp.	4C2431B
	LENS, indicator light: red-----	Cap for pilot lamp-----	4C2423B
	LENS, indicator light: white-----	Cap for line pilot lamp-----	4C2423A
	LENS, indicator light: white-----	Cap for line or trunk lamp-----	4C2427A
	MOUNTING, dial-----	Used for mounting dial on switch shelf.	4B1927
	PLUG, telephone: 3 cond-----	Terminates 3-conductor cord of cord circuit or dial cord circuit in switch shelf.	4C7053X
	PLUG, telephone: 4 cond-----	Terminates 4-conductor cord of operator's head and chest set in left front end of switch shelf.	4C7023
76.1-----	POUCH, tool: 10 oz canvas-----	Container for switchboard tools--	6R6534-1
96,110-----	RELAY, armature: 1.7 ohms d-c; 24 v oper 22 ma oper eur.	Closes a circuit through line pilot lamp on incoming call.	4C8561A
91, 108-----	RELAY, armature: 1 wnd; 500 ohms; 24 v d-c; .010 amp.	Operates to close a lamp circuit when ringing current is applied to cord test circuit.	4C8666XA
102-----	RELAY, armature: 2 wnd; 100-670 ohms; 24 v d-c; .015 amp.	Operates to light line lamp on incoming call.	4C8522A
79.1, 97, 104-----	RELAY, armature: 1 wnd; 500 ohms; 24 v d-c; .023 amp.	Operates when plug of cord circuit is inserted into line jack.	4C8536ZAC
79.1, 97, 106-----	RELAY, armature: 1 wnd; 500 ohms; 24 v d-c; .023 amp.	Operates to open line pilot lamp circuit.	4C8593ZB

Fig. No.	Name of part and description	Function of part	Signal Corps stock No.
79.1, 97, 105	RELAY, armature: 2 inductive wnd; 250-670 ohms; 24 v d-c; .25 amp.	Operates when ringing current is applied to trunk by distant operator.	4C8587ZWEY
81, 81.1, 109	RELAY, armature: 3 inductive wnd; 1 non-inductive wnd; 75 ohms, 175 ohms, 700 ohms, 2,200 ohms.	Relay 3 and relay 4 operate independently in the cord circuit when two common battery lines are connected together by the operator.	4C8603.75ZFY
82, 92, 103	RELAY, armature: 1 wnd; 100 ohms; 24 v d-c; .026 amp.	Operates to connect operator's telephone set to LISTEN switch of cord circuit.	4C8534ZAA
81.1, 93, 107	RELAY, armature: 2 wnd; 75-500 ohms; 24 v d-c; .035 amp.	Relay 1 and relay 2 operate independently when two common battery lines are connected together by the operator.	4C8602.96ZMN
88, 99	RESISTOR, fixed: WW; 50 ohms $\pm 5\%$	Current limiter	3Z6005-91
91	RESISTOR, fixed: WW; 1000 ohms $\pm 5\%$	Current limiter	3Z6100-171
93	RESISTOR, fixed: comp; 2200 ohms $\pm 5\%$ ; $\frac{1}{2}$ w.	Prevents shock to operator when plug is removed from line jack.	3R20BF222K
93	RESISTOR, fixed: comp; 47,000 ohms $\pm 10\%$ ; $\frac{1}{2}$ w.	Limits ringing current through receiver of calling telephone when operator rings called telephone.	3RC20BF473K
82, 92	RESISTOR, voltage sensitive	Reduces acoustic disturbances	4Z9710
85, 91	RESISTOR ASSEMBLY: 500 and 10,000 ohms $\pm 5\%$	The 10,000-ohm resistor simulates insulation resistance of line conductors. When this resistor is connected in parallel with the 500-ohm resistor, the effective resistance is 476 ohms, which simulates the resistance of the line loop including the telephone.	3Z6960-67
76, 76.1	SCREW DRIVER, common: slot drive; St Carl tool No. 42.	Used for tightening or removing switch and terminal screws.	6R40642
76.1	SCREW DRIVER TL-21: slot drive; St Carl tool No. 52.	Used for tightening or removing switchboard screws.	6R15310
112	SLEEVE, telephone jack	Removable portion of jack in jack assembly.	2Z8552-148
76, 76.1	SOCKET WRENCH AND SCREW-DRIVER COMBINATION: St Carl tool No. 24.	Used for removing $\frac{3}{16}$ -inch and $\frac{1}{4}$ -inch hexagonal nuts.	6R40624
68, 75, 81, 81.1, 84, 93.	SWITCH, lever: pile-up; 2 positions	Used to connect ringing current to cord circuit when required.	4C5063.41A
68, 75, 81, 81.1, 93.	SWITCH, lever: pile-up; 3 position, 2 locking, 1 nonlocking.	LISTEN unit used to connect operator's telephone to cord circuit. Ring unit used to connect ringing current to line.	4C5063.42KX
68, 85, 91	SWITCH, push	Used to connect 500-ohm resistor in parallel with 10,000-ohm resistor.	3Z9824-63.8
68, 85, 91	SWITCH, push	Used to connect ringing current to cord circuit being tested.	3Z9824-63.9
68, 88, 99	SWITCH, push	Used to partially close night alarm circuit.	4C5061.19
68, 89	SWITCH, push	Used to connect 24-volt battery to switchboard position.	4C5061.19-1

Fig. No.	Name of part and description	Function of part	Signal Corps stock No.
68, 84-----	SWITCH, push-----	Used to transfer cord circuit ringing leads from hand generator to 20-cycle supply.	4C5061.19-2
	WEIGHT, cord, switchboard-----	Returns cord to normal location after attached plug is removed from switchboard jack.	4C2910.0
76, 76.1-----	WRENCH TL-108: St Carl tool No. 2-----	For tightening or removing $\frac{3}{8}$ -inch hexagonal nuts.	6R57412
76, 76.1-----	WRENCH, spanner, hook: fork type end for 2 holes spaced $\frac{1}{4}$ " apart; St Carl tool No. 45.	For tightening or removing switchboard screws.	6R40645

[AG 412.42 (11 Aug 53)]

BY ORDER OF THE SECRETARY OF THE ARMY:

M. B. RIDGWAY,  
General, United States Army,  
Chief of Staff.

OFFICIAL:

WM. E. BERGIN,  
Major General, United States Army,  
The Adjutant General.

DISTRIBUTION:

*Active Army:*

Tech Svc (1); Tech Svc Bd (1); AFF Bd (ea Svc Test Sec) (1); AFF (5); AA Comd (2); OS Maj Comd (5); Base Comd (5); MDW (2); Log Comd (5); A (5); CHQ (2); FT (2); Sch (5) except 11 (25); PMS & T 11 (1); Gen Dep (2); Dep 11 (20) except Sig Sec, Gen Dep (10); Tng Div (2); POE (10), OSD (2); Lab 11 (5); Mil Dist (3); Field Maint Shops 11 (3); Two (2) copies to each of the following T/O & E's: 11-107; 11-127A; 11-128; 11-500A, CA, CB, CC, CD; 11-587; 11-592; 11-597.

*NG:* Same as Active Army except one copy to each unit.

*Army Reserve:* Same as Active Army except one copy to each unit.

For explanation of distribution formula, see SR 310-90-1.

SWITCHBOARDS SB-53/FTC AND SB-53A/FTC

TM 11-2087  
 TO 31W2-3SB53-1  
 CHANGES No. 2

DEPARTMENTS OF THE ARMY  
 AND THE AIR FORCE  
 WASHINGTON 25, D. C., 20 November 1956

TM 11-2087/TO 31W2-3SB53-1, 19 January 1950, is changed as follows:

Page 2, paragraph 4a.

Line 6: Add the following after "phones": or both.

Line 7: Add the following sentence: Supervision for the operator is provided on all magneto, common battery, or trunk calls.

Page 15, paragraph 24: Add the following at the end of the second sentence: on a common battery call or if the subscriber rings off on a magneto line call.

Page 64, paragraph 106: Add the following sentence to c:

The long lines are equipped with a more sensitive line relay than the short lines and, therefore, are reserved for the longest or most critical lines or trunks.

Add the following subparagraph: *d.* The operative limits of the switchboard are fixed by the maximum loop resistance over which satisfactory supervision is obtainable. This resistance is normally about 690 ohms with normal transmitter circuit resistance, average-to-good insulation, and proper central office battery voltage.

Page 69, paragraph 113c: Delete the last sentence.

Page 76, paragraph 124a(1), line 9: Change "467" to read: 476.

Figure 85. Delete the ground symbol on the jack sleeve of the left hand figure entitled "Magneto Cord Test with Ringing".

Page 79, figure 91. Delete the ground symbol on the jack sleeve of the left hand figure entitled "Magneto Cord Test with Ringing".

Figure 93. Cord circuit, wiring diagram, SB-53/FTC.

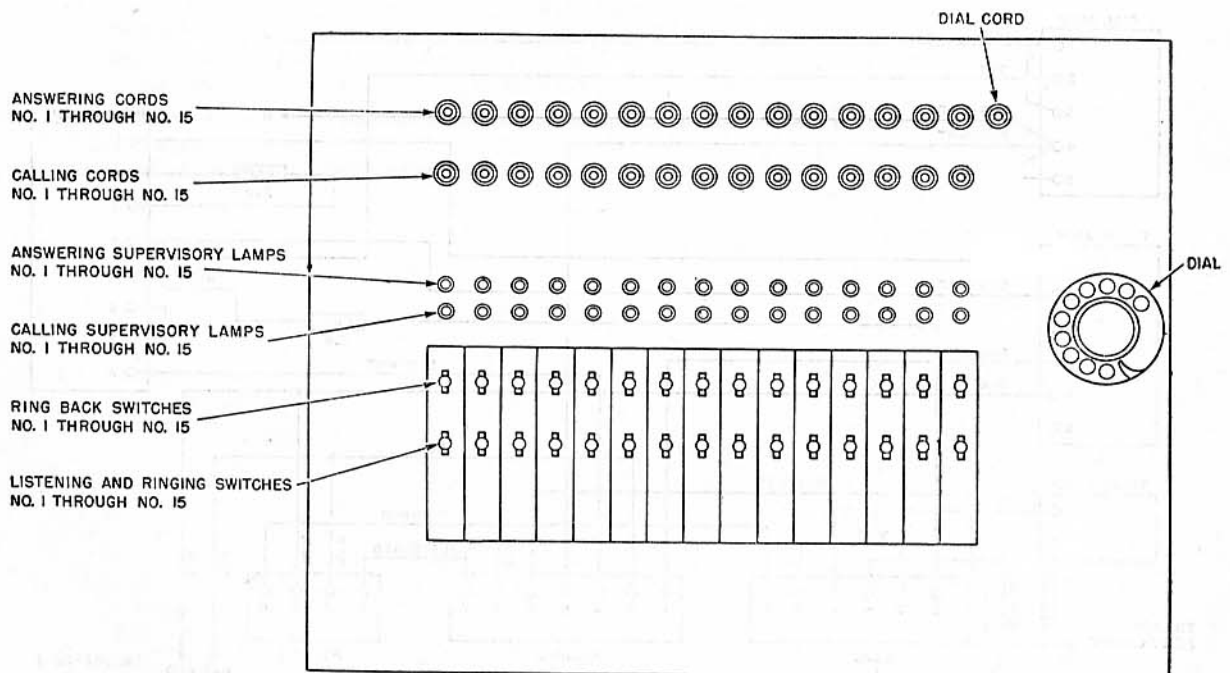

TM2087-C2-1

Figure 75 (Superseded) Top view of switch shelf, showing arrangement of cords, lamps, and switches.

Add the following note to figure 93:

Note. Relays numbered 3 and 4 supplied with SB-53A/FTC have a 650 ohm winding in place of the 620 ohm winding supplied with SB-53/FTC.

Figure 97. SB-53/FTC, universal trunk circuit, wiring diagram.

Page 89, figure 105 (p. 4, C 1). Change "257FY" to read: **257EY**.

Page 4 (C 1). Relocate the captions for figures 106 and 107.1 so that the caption for figure 106 is above the illustration (identified as TM 2087-C1-8) and the caption for figure 107.1 applies to the illustration.

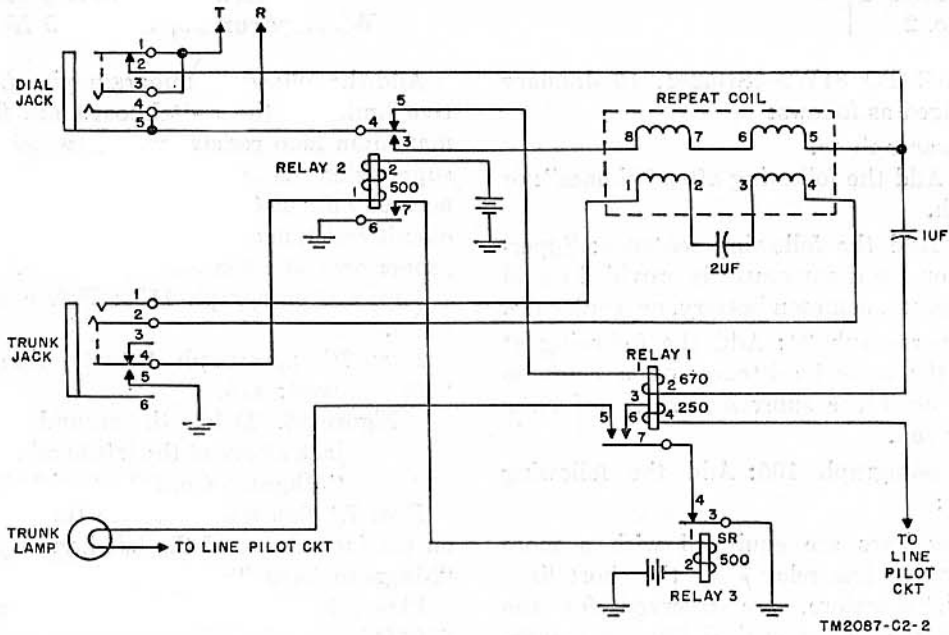

Figure 79.1. (Superseded) Switchboard SB-53A/FTC, universal trunk circuit, schematic.

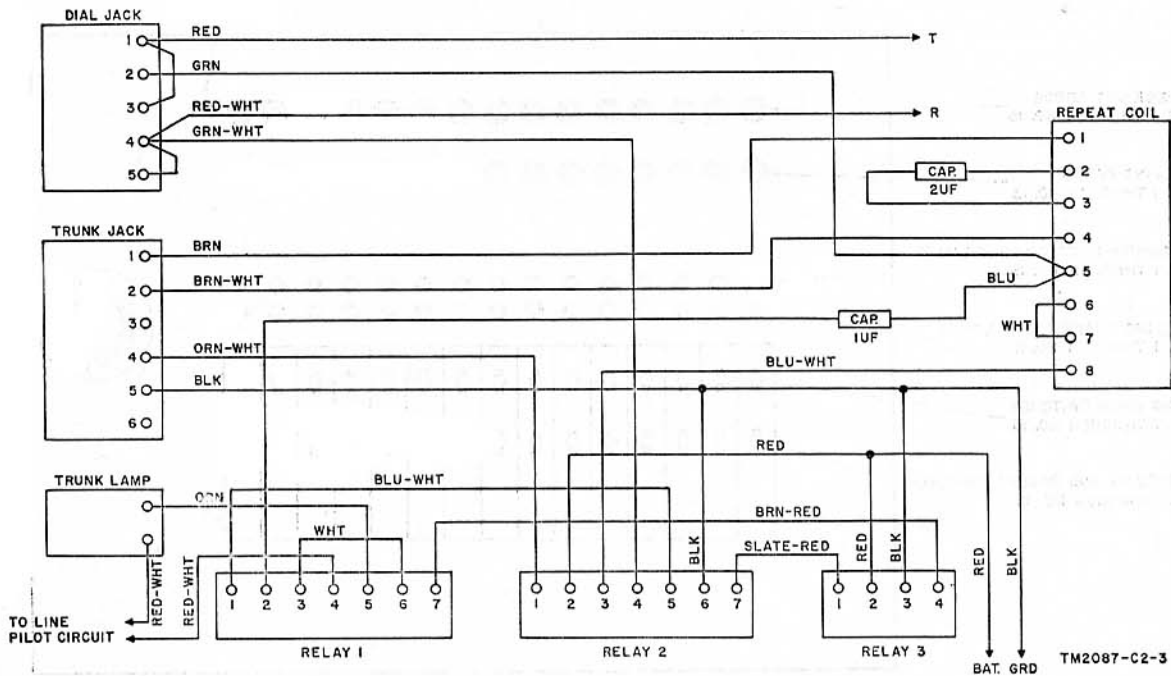

Figure 97.1. (Added) SB-53A/FTC universal trunk circuit, wiring diagram.

[AG 412.42 (2 Nov 56)]



BY ORDER OF THE SECRETARIES OF THE ARMY AND THE AIR FORCE:

MAXWELL D. TAYLOR,  
General, United States Army,  
Chief of Staff.

OFFICIAL:

JOHN A. KLEIN,  
Major General, United States Army,  
The Adjutant General.

OFFICIAL:

E. E. TORO,  
Colonel, United States Air Force,  
Air Adjutant General.

N. F. TWINING,  
Chief of Staff, United States Air Force.

DISTRIBUTION:

Active Army:

CNGB (1)  
ASA (3)  
Tec Svc, DA (1) except CSIGO (30)  
Tec Svc Bd (1)  
Hq CONARC (5)  
CONARC Bd (incl ea Test Sec) (1)  
Army AA Comd (2)  
OS Maj Comd (5)  
OS Base Comd (5)  
Log Comd (5)  
MDW (1)  
Armies (5)  
Corps (2)  
Ft & Cp (2)  
Sp Wpn Comd (2)  
Army Cml Cen (4)

Gen & Br Svc Sch (5) except Sig  
Sch (25)  
Gen Depots (2) except Atlanta  
Gen Depot (None)  
Sig Sec, Gen Depots (10)  
Sig Depots (17)  
US Army Tng Cen (2)  
POE (OS) (2)  
Trans Terminal Comd (2)  
Army Terminals (2)  
OS Sup Agencies (2)  
Army Elet PG (1)  
Sig Fld Maint Shops (3)  
Sig Lab (5)  
ACS (3)  
Mil Dist (1)

Units organized under following  
TOE's:  
11-7C, Sig Co, Inf Div (2)  
11-16C, Hq & Hq Co, Sig Bn,  
Corps or Abn Corps (2)  
11-57C, Armd Sig Co (2)  
11-127R, Sig Rep Co (2)  
11-128C, Sig Depot Co (2)  
11-500R, Sig Svc Ord (2)  
11-557C, Abn Sig Co (2)  
11-587R, Sig Base Maint Co (2)  
11-592R, Hq & Hq Co, Sig Base  
Depot (2)  
11-597R, Sig Base Depot Co (2)

NG: State AG (6); units—same as Active Army except allowance is one copy to each unit.

USAR: None.

For explanation of abbreviations used, see SR 320-50-1.