

# KELLOGG SWITCHBOARD AND SUPPLY COMPANY

An Associate of International Telephone and Telegraph Corporation

Chicago, Illinois



## *Kellogg Bulletin 880, 1952* *Crossbar Dial Telephone Switching* *Equipment*

Published in a vertical format 8½ inches wide and 11 inches high, and lithographed on 60# coated paper in two colors, black and yellow. The publishing date of 1952 is stated with the form number 880 5M 10-52 on the back cover. Also of note is the Kellogg/ITT Associate logo which was used only during the period 1951-52 when ITT was buying Kellogg.

Scanned and produced by Mike Neale  
from an original document furnished by Roger Conklin  
Members of  
Antique Telephone Collectors Association US  
Telephone Collectors International US  
Telecom Heritage Group UK

Adobe document copyright 2005, Mike Neale & Roger Conklin, Midland, Texas, USA



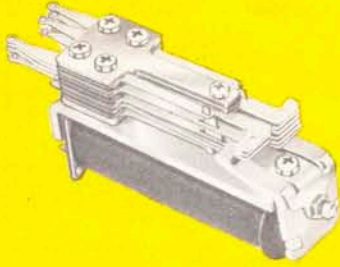

# CROSSBAR...

**KELLOGG'S**

*achievement  
of the  
century!*

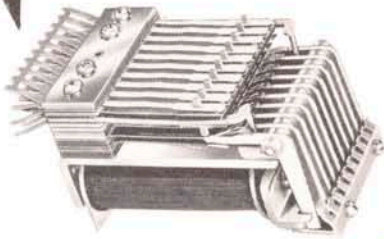

# The **KELLOGG** **CROSSBAR**

## Dial Telephone Switching Equipment

### GENERAL

A Telephone System is a network of lines and equipment arranged in such a manner that a subscriber may be connected to another within the area served by that particular system. The original dial switching systems established their connections by means of various electrical and mechanical devices.



FIGURE No. 1  
Kellogg Crossbar Switch

The Crossbar System is an arrangement whereby connections are made through precious metal contacts which are a part of two crossed bars lying at right angles. Trunks are made available to a number of lines by connecting the trunks to the bars extending in one direction and connecting the lines to the bars extending in the other direction.

The Kellogg Crossbar System derived its name from the Crossbar Switch. Fig. No. 1 shows one of the Crossbar switches. It can be seen that there are a large number of bars extending from front to back and a smaller number of bars extending from left to right. The bars extending from front to back are known as vertical bars and those extending from left to right are horizontal bars. Where the bars cross, a set of contacts are associated with each bar which can be made to establish a path from one bar to the other that crosses at right angles. Under the bars are five or six rods extending from left to right completely across the switch. These are known as select rods and

each rod is associated with two of the bars extending from left to right. The function of the select rods is to select the set of contacts which are to be closed. Fig. No. 2 shows a diagram of a contact section of the Crossbar type switch with two horizontal paths and four vertical paths. When one set of contacts is made, one vertical and one horizontal path are connected together. The Kellogg Crossbar switch is composed of a number of such vertical and horizontal bars with their associated contacts.

Previous mechanical dialing systems have established a connection by moving a set of wipers over a large number of terminals. Associated with the wipers of the previous systems, is a number of heavy parts which have to be moved a considerable distance before the connection is completed. The accumulation of dirt on the surface of the terminals and wipers, form a high resistant contact which causes noisy connections and results in considerable maintenance effort to keep the contacts workable.

Dial maintenance experience over the past 60 years has disclosed almost insurmountable problems in the expense and effort of adjustment, lubrication and replacement of the moving parts.

The resistance of base metal contacts and the noise elements introduced through their use is such that,

ing over of many contact terminals, precious metal can be used for the surface of the contacts.

The Kellogg Crossbar system contains only three basic units—The Crossbar Switch, The Magnetic Impulse Counter and The 4000 Type Relay.

The **Crossbar Switch** is mounted on a framework,

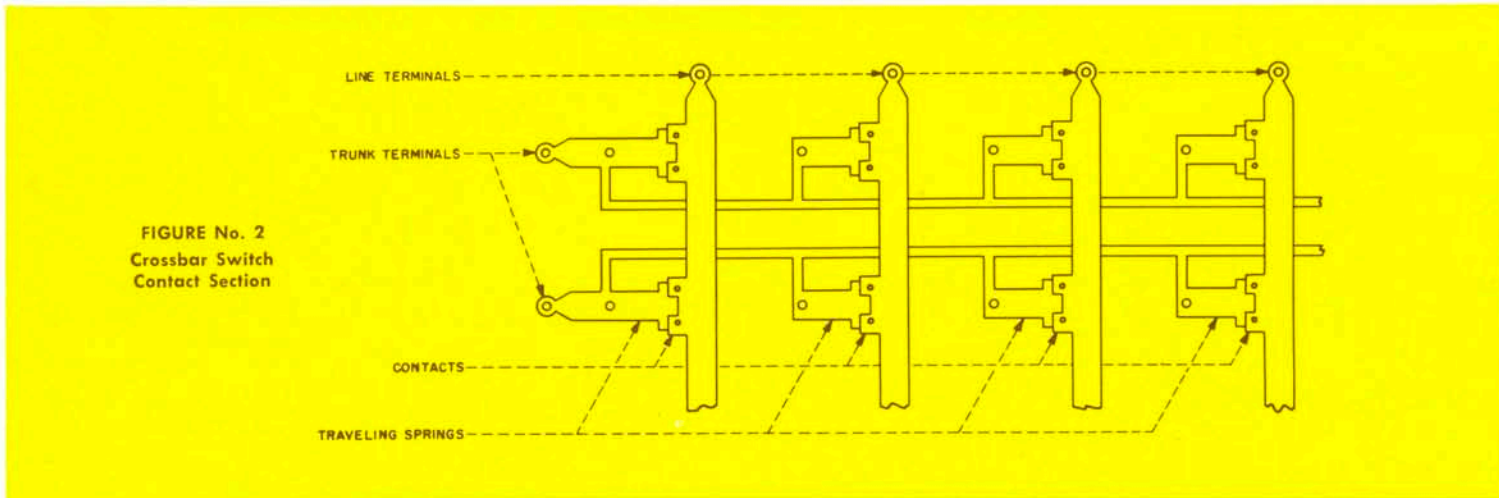

FIGURE No. 2  
Crossbar Switch  
Contact Section

toll connections operated through repeaters and carriers are adversely affected.

The Crossbar switch, we believe, has overcome most of the objectionable features found in other types of mechanical switching. The system is the peak of simplicity and incorporates a minimum of components.

Crossbar equipment is another electro-mechanical system differing fundamentally from any previous dial switching system that has yet been devised.

The Crossbar connection is radically different from most types of switched connections insofar as a direct path is established through precious metal contacts with no more movement of parts than the operation of relay armatures. No connections are made by brushes or wipers moving over a large number of terminals.

Crossbar connections are established by the simple operation of a relay armature moving only a few thousandths of an inch, and in tenths of seconds, instead of through the operation of mechanical stepping devices moving over several inches of space in a much greater length of time.

Fig. No. 3 shows one set of crossbar contacts in a made position. Since the path is established simply by the closing of these contacts, rather than the wip-

composed of front and rear rails joined together with short end members. There is a small number of different length switches, the longest of which is  $44\frac{1}{2}$  inches and the shortest  $32\frac{1}{2}$  inches. The difference in size is governed by the number of vertical bars needed. The make up of all Kellogg Crossbar switches is identical, which makes it ideal for mass production.

The select rods, which select the crossing Crossbar contacts to be made, are contained in the bottom por-

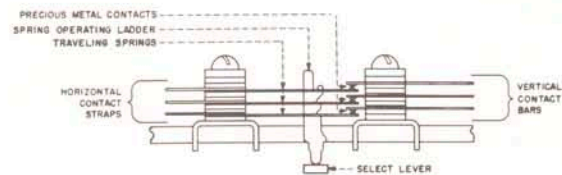

FIGURE No. 3  
Crossbar Contact Assembly

tion of the switch frame. Select rods are pivoted on shaft brackets and also carry the select magnets—a pair for each select rod.

The contact bank of the Crossbar switch is mounted on top of the frame, supported by cross rails.

The bank is made up of stacked members which lie in two right angle directions. Those stacks extending from left to right are called horizontal and those extending from front to back are called vertical. Each horizontal row and vertical contact multiples are built-in multiples and are part of the contact springs. No wire multiple with soldered connections is required.

The hold armature of the Hold Magnet associated with each vertical row is pivoted between the front and rear rails, a part of which extends entirely across the frame under each Crossbar contact point in that vertical row. A cross section of the switch operating

mechanism is shown in Figures No. 4 and No. 5.

To operate a set of contacts, the select rod moves either right or left moving the select lever under the contact ladder as shown in Fig. No. 5. The Hold Magnet operates and pushes the select lever and contact ladder upward, making the contacts. The select rod returns to normal but the select lever remains in operated position under the contact ladder.

The Hold Armatures operate and hold closed any set of contacts in its row which the select rod selects. The hold armatures are controlled by individual Hold Magnets which are mounted on the lower flange of the rear of the switch. In addition to the regular contact banks of the switch, the hold armature is provided with an extra set of contacts which are used for special circuit functions.

The only movement in a Crossbar switch is the rocking motion of the select rods on their pivots and the operation of the Hold Magnet armatures. Since there are no ratchets, wipers, brushes, or commutators, there are no small parts to wear out. Each of the piece parts of the Crossbar switch is built for a lifetime of service.

Fig. No. 6 shows a 20x20 Crossbar Switch, which has 20 verticals and ten double horizontal paths.

Diagram "A" shows the number of paths available and Diagram "B" shows the circuit for selecting an upper or lower level trunk through the use of a sixth select rod.

In Diagram "B" one of the regular select rods has first moved the select lever under vertical No. 1, and

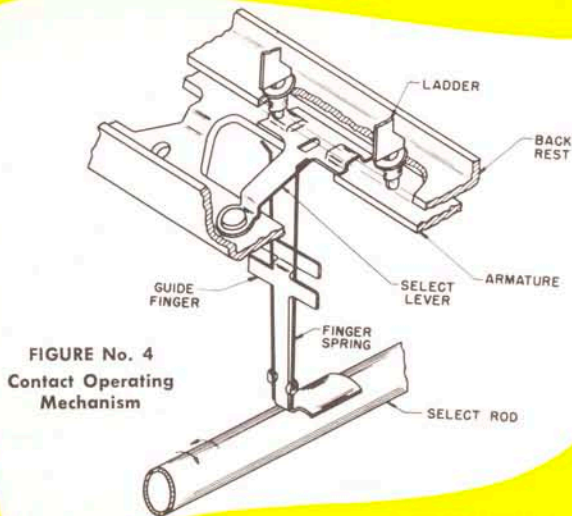

FIGURE No. 4  
Contact Operating  
Mechanism

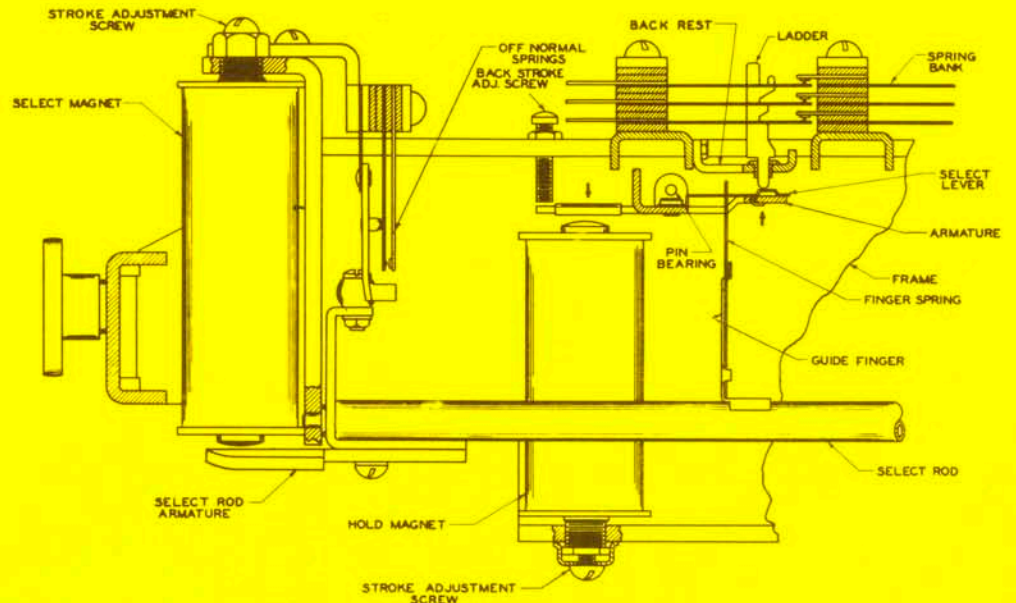
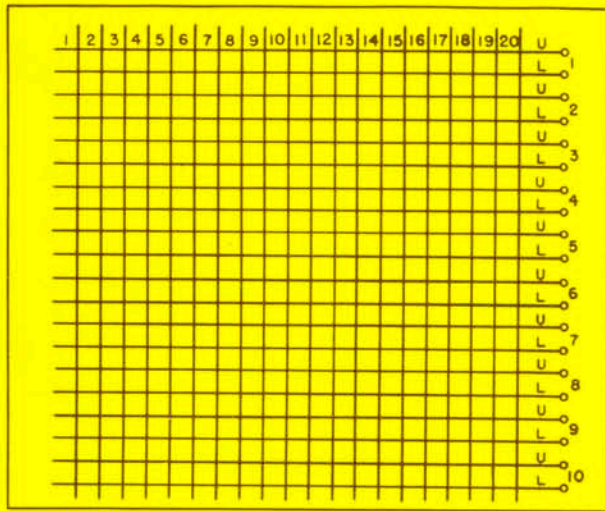
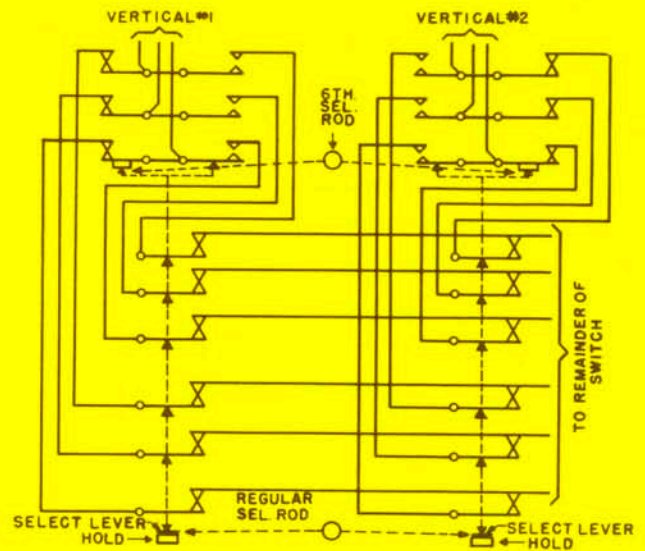

FIGURE No. 5  
Trunk Selecting and  
Contact Operating  
Mechanism



20 x 20 Crossbar Switch (A) Trunking Paths



Upper and Lower Level Circuit Arrangement

FIGURE No. 6

the 6th rod has moved a select lever under one set of contacts then the Hold Magnet has operated to connect vertical No. 1 to the lower level trunk. The procedure is the same for the connecting vertical No. 2 to the upper level trunk. The regular and 6th rod operate simultaneously and release when the Hold Magnet operates to make the contacts.

Once a vertical path has been assigned to one of the upper or lower trunks, the other upper or lower trunk is available to all other verticals. The first five rods are arranged to operate the ten horizontals in a normal manner. The 6th rod works in conjunction with any one of the first five and operates additional contacts, so that if operated in one direction, the vertical will be connected to the upper level, and if operated in the opposite direction, the vertical will be connected to the lower level.

Fig. No. 7 shows the left end section of the top of a crossbar switch outlining the horizontal and vertical crossing bars and contacts. The vertical contacts are fixed and extend from the left hand side of the vertical cross member, completely across the switch. The metal strip containing the vertical contacts is a solid strip extending over all of the horizontal contacts.

The horizontal contacts are separate springs with double contacts and are located under the vertical contacts. These separate springs are part of the continuous piece of metal extending horizontally over the entire length of the switch. The horizontal springs are travelling springs and operate from the hold magnet.

The springs located at the rear of the switch as shown

in Fig. No. 7 are special feature springs and operate each time the hold magnet operates.

It will be noted at the rear of the switch, there is space for an additional set of horizontal bars.

The eleventh and twelfth horizontal bars are used with the selector switch to give that switch the capacity of twelve trunks.

The 6th select rod which operates under the vacant position shown in Fig. No. 7 is used on any of the 20x20 Crossbar switches to select the upper or lower level of contacts.

Fig. No. 7 shows three spring assemblies at the left hand end of the switch. These spring assemblies are the off-normal contacts of the select rods. The off-

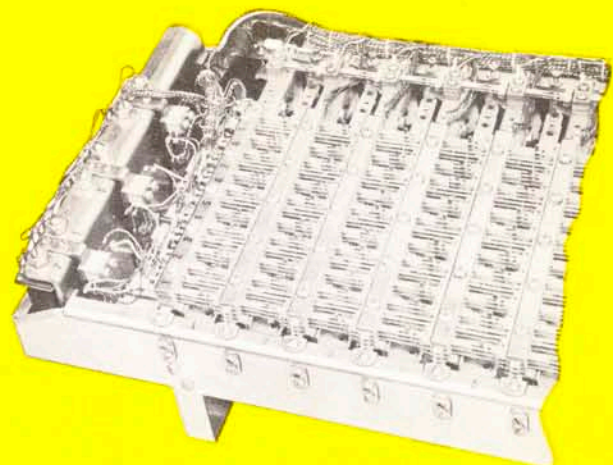

FIGURE No. 7  
Crossbar Switch Section

normal contacts of the remaining select rods are mounted on the opposite end of the switch.

The cable shown connected to the switch is the cable carrying the line connections. No loop wiring is necessary between the contacts of the switch, as all contacts are a part of the solid crossbars.

The **Magnetic-Impulse Counter** is composed of a single core and coil assembly with ten separate armatures and their associated contacts. The armatures are arranged to operate successively and respond respectively to the pulses received. One impulse counter is included in the Selector or Connector for each digit of the dialing plan.

The first armature or "finger" of the counter operates on the first impulse received. The operation of the first armature permits the second armature to step halfway forward. When the second impulse is received, the second armature completes a full operation and so on until the first digit is complete.

Diagram A of the Fig. No. 8 shows the magnetic pulse curve during the operation of dialing. Before a pulse is received, the magnetism of the core is zero. Upon the receipt of each pulse, the core is fully magnetized and between pulses, the residual magnetism remains at some 20% of the pulsing current. After all pulses are received, the armatures of the counter are held in place by residual magnetism only.

Diagram B of Fig. No. 8 shows the contact arrangement of the impulse counter. As each armature operates, the upper contact breaks and the lower contact makes. If, for example, the digit 5 is dialed, ground would be closed through the upper contact of armature No. 6, thereby marking the No. 5 lead.

Diagram C of Fig. No. 8 shows the load spring arrangement for holding armatures 2 to 0 inclusive against the back pole piece until the preceding armature has been operated. Since there is no load spring on armature No. 1, this armature remains in half-step position until the first pulse is received.

Upon receipt of the first pulse, armature No. 1 operates and removes the load spring from armature No. 2 allowing this armature to half-step forward and so on for as many impulses as are received.

Diagram D of Fig. No. 8 shows the circuit arrangement of the counter together with the first armature standing in half-step position. It will be noted that the pole piece of the core is extended under and in back of the armatures affording a front and back pole piece. The back pole piece is considerably smaller than the front pole piece and a magnetic force exerted on the back of the armature is proportionately smaller than that on the front of the armatures.

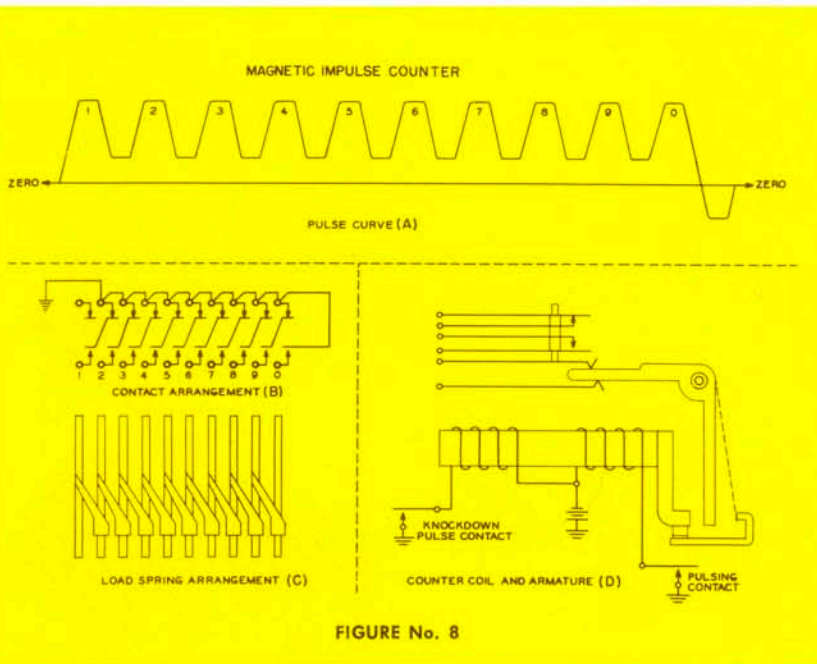

FIGURE No. 8

When the complete number has been dialed, the number of armatures which remain operated on each counter, is identical with the number of impulses sent by each digit dialed.

Sketches covering the detail operation of the magnetic impulse counters are shown in Fig. No. 8.

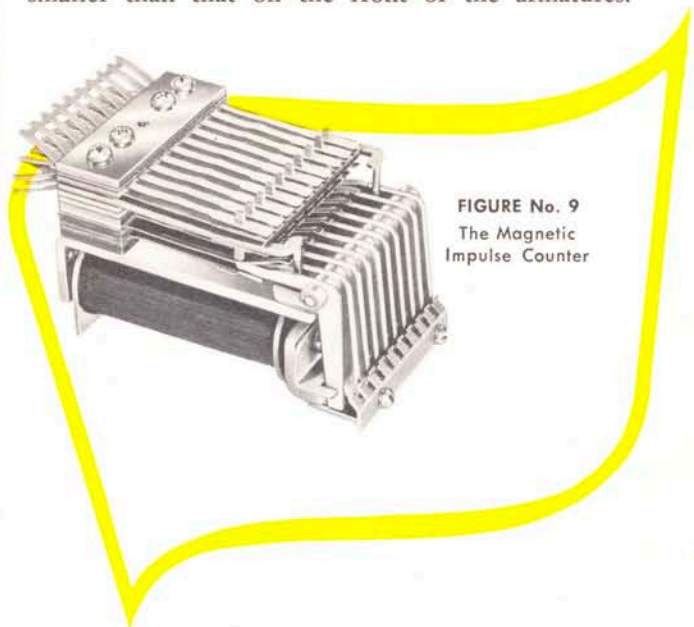

FIGURE No. 9  
The Magnetic  
Impulse Counter

When a digit is dialed into the counter, the first armature, being in half-step position, operates on the first pulse and all other armatures are held by the magnetism of the back pole piece. When the pulse is complete, the residual magnetism of the core holds the first armature operated.

The second armature moves to half-step because the load spring has been raised by the operation of the first armature, allowing the tension of the bottom spring of the second armature to pull the armature away from the back pole piece into half-step position. On the second pulse, the second armature operates and continues until the dialed digit has been registered. Since the armatures are held by residual magnetism, no current is flowing in the coil and no central office battery is used for this holding operation.

When the counter circuit is released upon the completion of a call, a pulse is received in the "knock-down" winding of the coil. The knock-down pulse is received in the opposite direction from the regular pulse and is of sufficient strength to cancel the residual magnetism releasing all armatures, and restoring the counter to non-operated position.

Fig. No. 9 shows a picture of the Magnetic Impulse Counter.

The 4000 Type Relay is an all-purpose relay that is arranged to mount either individually or on a common heel-iron. A standard spring assembly is furnished that varies only in the spring combination. The spring assembly is constructed in one unit and can be installed or removed in one piece. The relay has a ladder arrangement which actuates the traveling springs in such a manner that adjustment requirements are minimized. Each set of contacts is composed of a traveling spring and a non-movable anvil type spring. The springs are fitted with double bar contacts and when the contact of the traveling spring is made with the contact of the non-movable spring, a considerable wiping motion is effected.

The armature is attached with a retaining clamp and a single screw to the heel iron which provides for ease of assembly as well as adjustment.

Fig. No. 10 shows a picture of the 4000 Type Relay. A back-stop screw is provided in the armature, which

in conjunction with the retaining clip screw provides any adjustment that might be required.

The relay coils are all of a standard overall size and are provided with the necessary spool ends and terminals. The coil terminals are attached in such manner that they extend below the heel-iron and to the proper location for wiring.

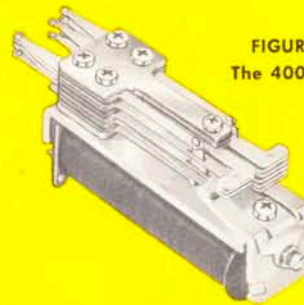

FIGURE No. 10  
The 4000 Type Relay

THERE IS A KELLOGG CROSSBAR  
SYSTEM TO FIT ANY TYPE OR  
SIZE TELEPHONE EXCHANGE

**KELLOGG** AN IT&T  
ASSOCIATE \*\*\*\*\* An Associate of Inter-  
national Telephone and  
Telegraph Corporation

**KELLOGG SWITCHBOARD AND SUPPLY COMPANY**

Sales Offices: 79 W. Monroe, Chicago 3, Ill.

Factory: 6650 S. Cicero Ave., Chicago 38, Ill.



**Crossbar  
Frames**

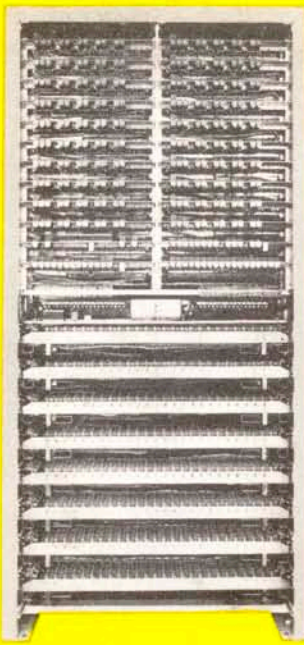

Line Frame

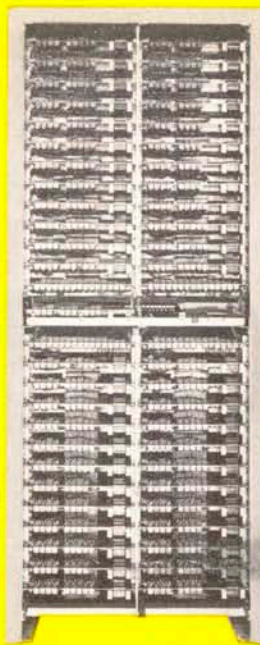

Selector Relay Frame

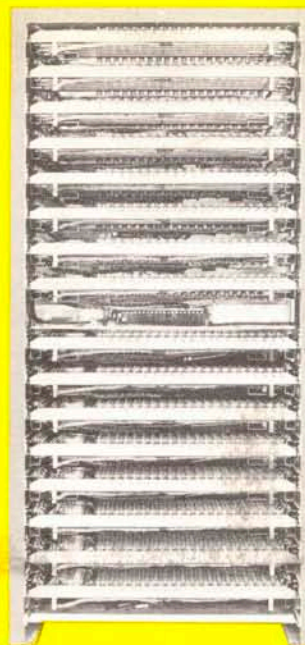

Selector Switch Frame

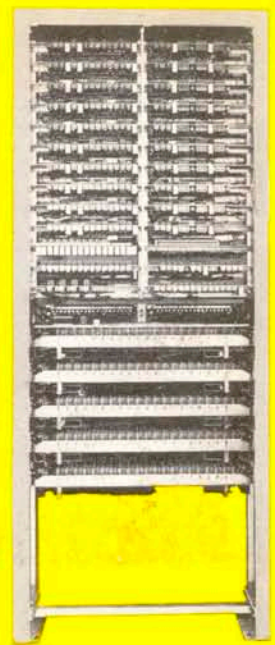

Connector Frame

**TYPICAL KELLOGG CROSSBAR INSTALLATIONS LARGE and SMALL  
10 TO 10,000 LINES**

Sioux Center, Iowa



Latayette, Georgia



Transfer,  
Pennsylvania



Lime Springs,  
Iowa

**KELLOGG** AN IT&T ASSOCIATE

An Associate of International Telephone and Telegraph Corporation

**KELLOGG SWITCHBOARD AND SUPPLY COMPANY**

Sales Offices: 79 W. Monroe, Chicago 3, Ill.

Factory: 6650 S. Cicero Ave., Chicago 38, Ill.