

## INSTALLATION

### A. E. CO. PAYSTATIONS

#### 1. GENERAL

1.01 This addendum is issued to revise and expand the procedures for installation testing of paystations. With ink or red pencil, write in margin at paragraphs 2.03, 2.04, 2.05, and 2.06: "See addendum paragraph 1.02." Write in margin at step (4) of paragraph 2.07: "See addendum paragraph 1.03." In step (1) of paragraph 2.08, delete: "Check for money refund."

1.02 Each step (1) of paragraphs 2.03 through 2.06 specifies the deposit of 2 nickels before dialing. On paystations equipped for two-nickel control, the installer should check that a call cannot be dialed through after the deposit of

the first nickel, then the second nickel should be deposited. On paystations equipped for dime-only control, a dime or quarter must be deposited to dial. On paystations equipped for five-cent service, the installer deposits one nickel, dime, or quarter to dial.

1.03 On semi-postpay paystations equipped for five-cent service, a nickel deposited after the called party answers will remove the transmission block.

1.04 Wherever appropriate (depending on local test facilities), the installer should call a local test board or preassigned number instead of the operator as specified in this GSP.

INSTALLATION

A. E. CO. PAYSTATIONS

1. GENERAL

1.01 This section contains installation procedures for A. E. Co. paystations.

2. INSTALLATION

2.01 Installation of a paystation in an aluminum booth is described in GSP 476-500 series. Install a paystation in a wood booth or on a wall as follows:

- (1) Place the backboard (see Fig. 1) against the wall vertically (it is important that the backboard and the paystation are exactly upright).
- (2) Mark through holes B onto wall.
- (3) Drill holes, where marked, to take 1/4-20 anchors. Mount anchors in wall.
- (4) Push a loop of inside wire through backboard hole C.

NOTE: When installing a paystation in a wood booth or on a wall, a #14 ground wire must be connected between the paystation lower housing and protector ground as described in Part 3. The ground wire must be connected to the paystation before the paystation is mounted on the backboard.

- (5) Carry remainder of inside wire down channel at rear of backboard.
- (6) Push end of inside wire through hole marked D.

NOTE: If inside wire runs along bottom of paystation booth or enclosure, push a loop of inside wire through hole D; carry inside wire up channel at rear of backboard and push end of wire through hole C.

- (7) Mount the backboard on the wall using anchor screws.
- (8) Unlock upper housing of paystation and lift housing off.
- (9) Mount lower housing and backplate onto backboard with 1/4-20 flathead machine screws through the threaded insert of holes A.

- (10) Insure that the loop or end of inside wire comes through slot in backplate by terminal strip without pinching.
- (11) Remove cover from ringer box.
- (12) Mount ringer box on the bottom part of the backboard using common wood screws.
- (13) Insure that the inside wire is not pinched and has free access to the ringer box.
- (14) Connect ringer and lower housing as shown in the appropriate wiring diagram (Figs. 3 through 16).

NOTE: Paystations installed in wood paystation booths must be grounded according to the instructions in Part 3 of this section.

- (15) Replace cover on ringer box.
- (16) Replace upper housing on paystation and lock.

2.02 In addition to the standard installation tests to verify ringing, dial speed, and line noise level, the following specific installation tests should be performed as outlined for each type of paystation.

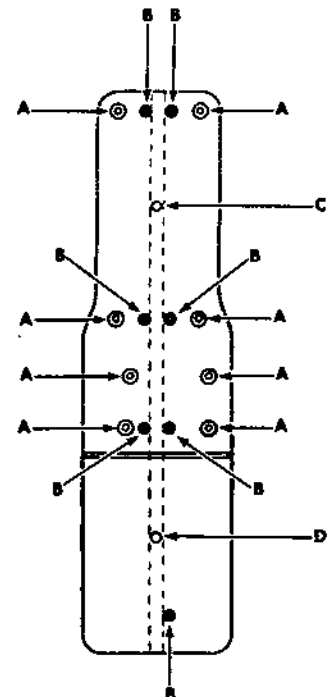

Figure 1. Backboard

Tests - Prepay Stations

2.03 When the cash compartment key is available or the cash compartment door is not installed, check operation of prepay paystation as follows:

- (1) Insert two nickels, dial paystation number and wait for busy tone. Hang up. Check for coin refund.
- (2) If in place, remove cash compartment door if key is available.
- (3) Insert dime and dial test line.
- (4) When connection is completed to test line, hang up.
- (5) Check that coin falls into cash compartment.
- (6) Repeat same procedure (steps 3 through 5) with a quarter.
- (7) Deposit dime. Dial operator for assistance with coin signal testing.
- (8) Deposit proper coin in each slot and have operator identify each coin deposited.
- (9) Have operator apply refund current. Check that coins drop into coin return receptacle.
- (10) Re-deposit coins and have operator apply collect current. Check that coins drop into cash compartment.
- (11) Lock cash compartment door.

2.04 When a cash compartment key is not available and the cash compartment door is in place, check prepay paystations as follows:

- (1) Insert two nickels, dial telephone number of paystation being installed and wait for busy tone. Hang up. Check for money refund.
- (2) Insert dime. Call operator for assistance in coin signal testing.
- (3) Deposit proper coin in each slot and have operator identify each coin. Hang up.

Tests - Local Prepay Paystations

2.05 When cash compartment key is available or

cash compartment door is not installed, check operation of local prepay paystation as follows:

- (1) Insert two nickels, dial paystation number and wait for busy tone. Hang up. Check for coin refund.
- (2) Unlock cash compartment door.
- (3) Insert dime and dial test line.
- (4) When connection is completed to test line, hang up.
- (5) Check that coin falls into cash compartment.
- (6) Repeat steps (3) through (5) using a quarter.
- (7) Deposit dime. Dial operator for assistance with coin signal testing.
- (8) Deposit proper coin in each slot and have operator identify each coin deposited. Check that coins fall into cash compartment. Hang up.
- (9) Lock cash compartment.

2.06 When cash compartment key is not available and cash compartment door is installed, check local prepay paystations as follows:

- (1) Insert two nickels, dial telephone number of paystation being installed and wait for busy tone. Hang up. Check for coin refund.
- (2) Insert dime. Call operator for assistance in coin signal testing.
- (3) Deposit proper coin in each slot and have operator identify each coin. Hang up.

Tests - Semi-Postpay Paystations

2.07 When a cash compartment key is available or cash compartment door is not installed, check operation of a semi-postpay paystation as follows:

- (1) Dial paystation number and wait for busy tone. Hang up.

- (2) Unlock cash compartment door.
- (3) Dial predetermined party for assistance in checking paystation operation. Do not call operator.
- (4) When called party answers, deposit one nickel. On semi-postpay paystations using dime-only control, the nickel will be rejected. If the paystation has two-nickel control, the first nickel will be accepted but transmission will remain blocked until second nickel is deposited. On paystations with two-nickel control, deposit second nickel to determine that transmission block is removed. Hang up.
- (5) Call predetermined party.
- (6) When called party answers, deposit dime. Transmission block should be removed.
- (7) Repeat (5) and (6) using quarter.
- (8) Dial operator for assistance with coin signal testing.
- (9) Deposit proper coin in each slot and have operator identify each coin deposited. Hang up.
- (10) Lock cash compartment door.

2.08 When a cash compartment key is not available, and cash compartment door is installed, check operation of semi-postpay paystation as follows:

- (1) Dial number of paystation and wait for busy tone. Hang up. Check for money refund.
- (2) Call operator for assistance in coin signal testing.
- (3) Deposit proper coin in each slot and have operator identify each coin. Hang up.

### 3. PAYSTATION HOUSING GROUND

#### Grounding Prepay Paystations

3.01 Where a prepay paystation is installed in a

wood booth or mounted on a wall, the paystation must be grounded as follows:

- (1) Solder a spade terminal to each end of an 11-inch #14 wire. Terminate one end under the mechanism base machine screw shown in Fig. 2. Route wire to avoid coin return chute opening and coin trigger and terminate the other spade terminal at the terminal strip ground terminal G. Solder a spade terminal to one end of a #14 wire (wire length sufficient to reach from terminal G through the lower housing wire opening and to the protector ground terminal). Terminate the spade terminal at terminal G. Route the #14 wire through the lower housing wire opening to the protector and wrap the end of the wire around the protector ground terminal.
- (2) At the point on the edge of the upper housing which will contact the equalizing spring when the upper housing is installed (see Fig. 2), remove sufficient paint from the inside surface so that a ground clip can make contact with the metal of the upper housing. Place a Tinnerman C-23405-012-3E ground clip on the upper housing at the point where it will contact the equalizing spring when the housing is installed.

#### Grounding Local Prepay and Semi-Postpay Paystations

3.02 Where a local prepay or semi-postpay paystation is installed in a wood booth, the paystation must be grounded as follows:

- (1) Solder a spade terminal to one end of a #14 wire (wire length sufficient to reach from mechanism base mounting screw, through wire opening in lower housing to protector ground terminal). Terminate the spade terminal under the mechanism base mounting screw shown in Fig. 2. Route the wire through the lower housing to protector ground terminal (wire must be routed so that it does not obstruct coin return chute opening or coin trigger). Wrap the end of the wire around protector ground terminal.
- (2) Install a ground clip as described in paragraph 3.01 step (2).

3.03 Station protection and grounding requirements are described in the 435-300 and

435-600 series of GSP's. These practices should be referred to for station wiring to the paystation.

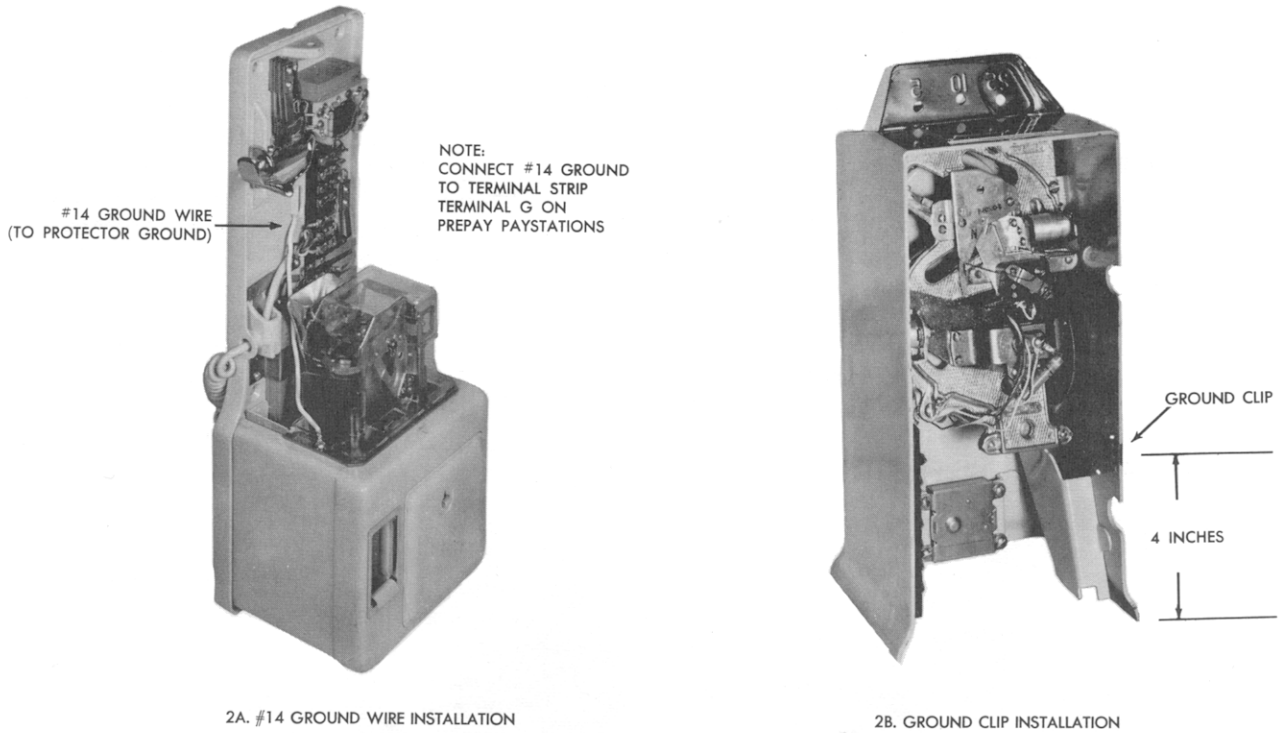
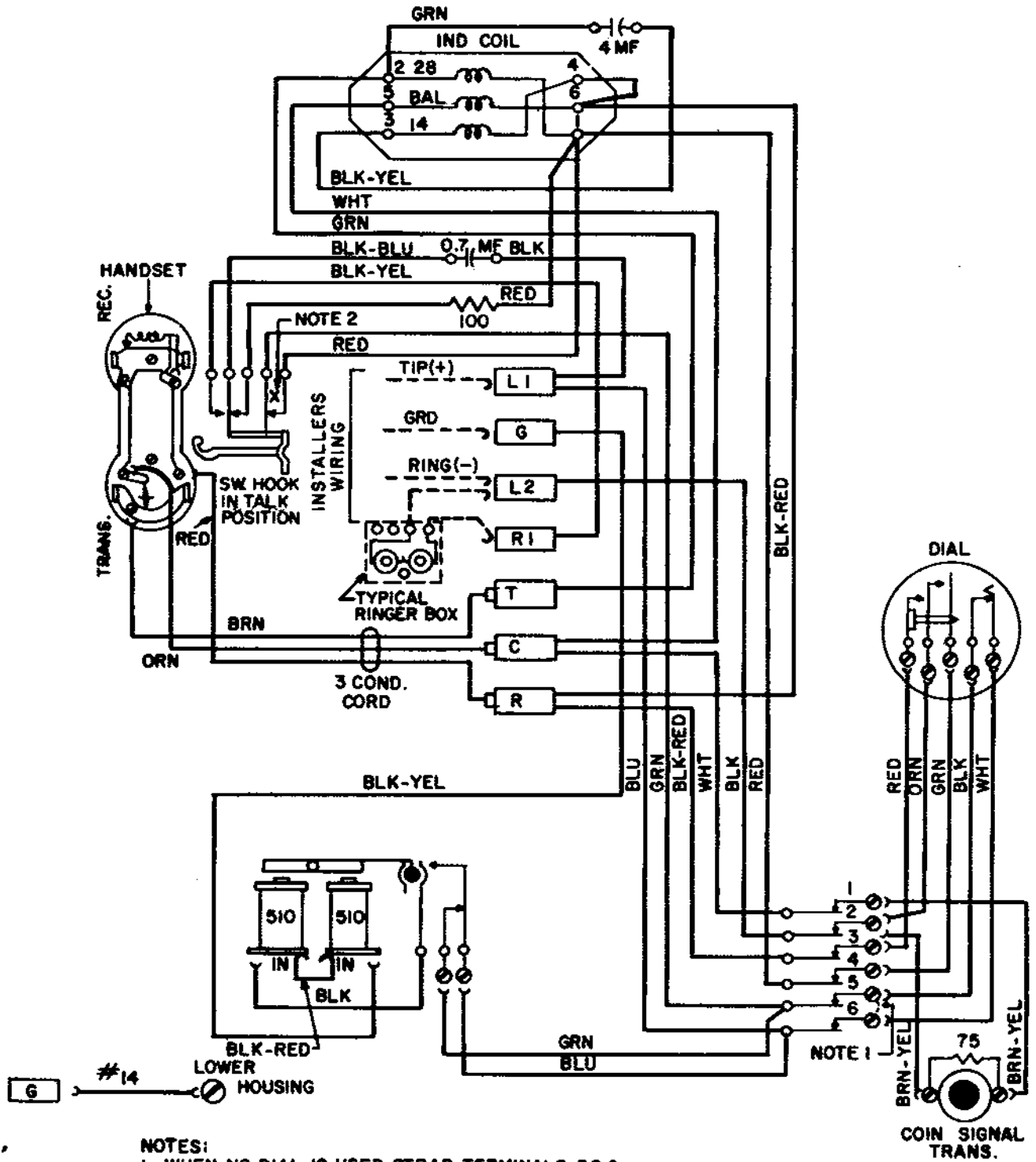

Figure 2. Paystation Grounding - Wall-Mounted or Mounted in Wood Booth



- NOTES:  
 1. WHEN NO DIAL IS USED STRAP TERMINALS 5&6.  
 WHEN NO RELAY IS USED TAPE LEADS  
 2. "X" CONTACTS TO BREAK FIRST AND MAKE LAST.

Figure 3. Type 62 Prepay Paystation Wiring Diagram

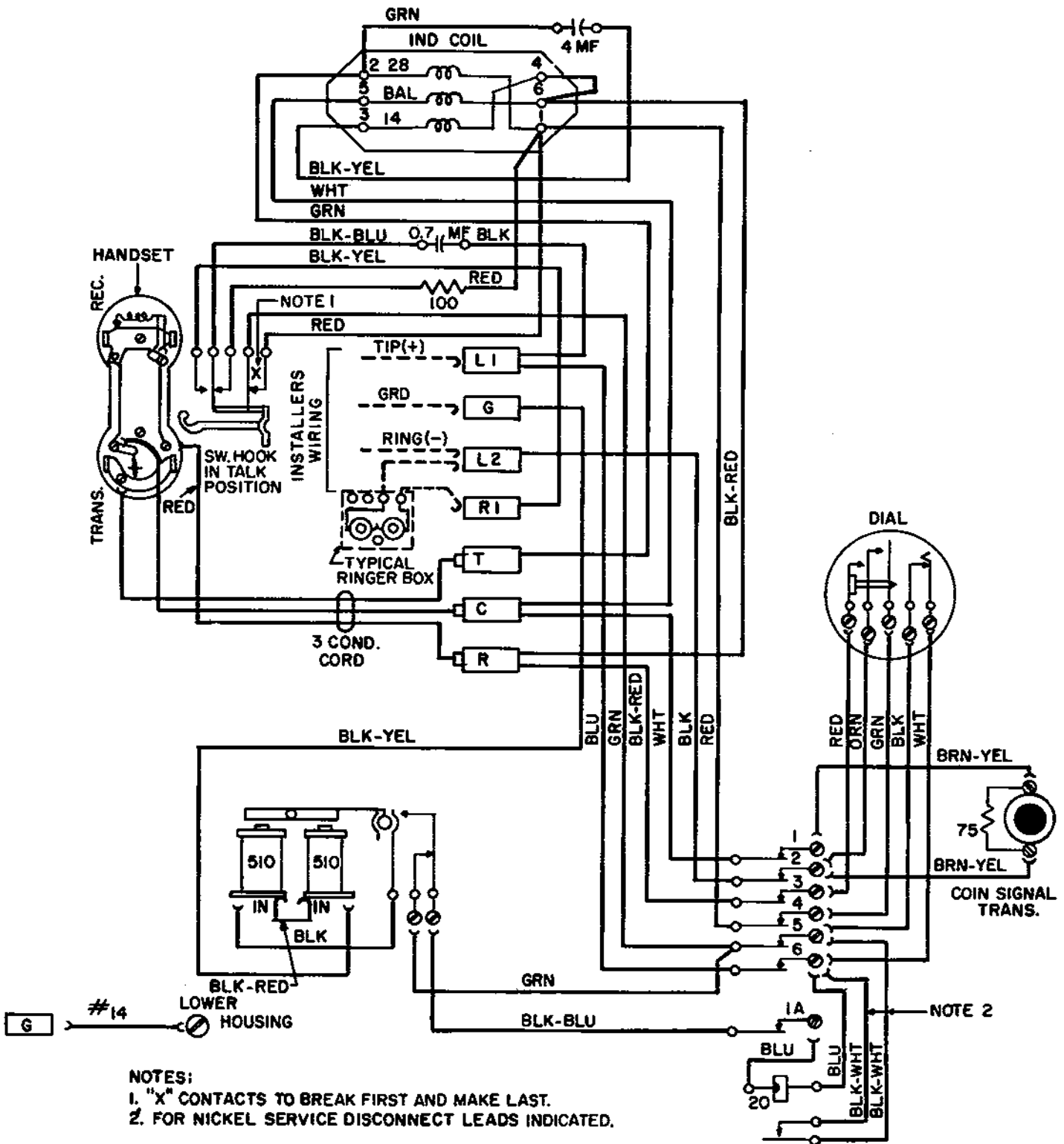
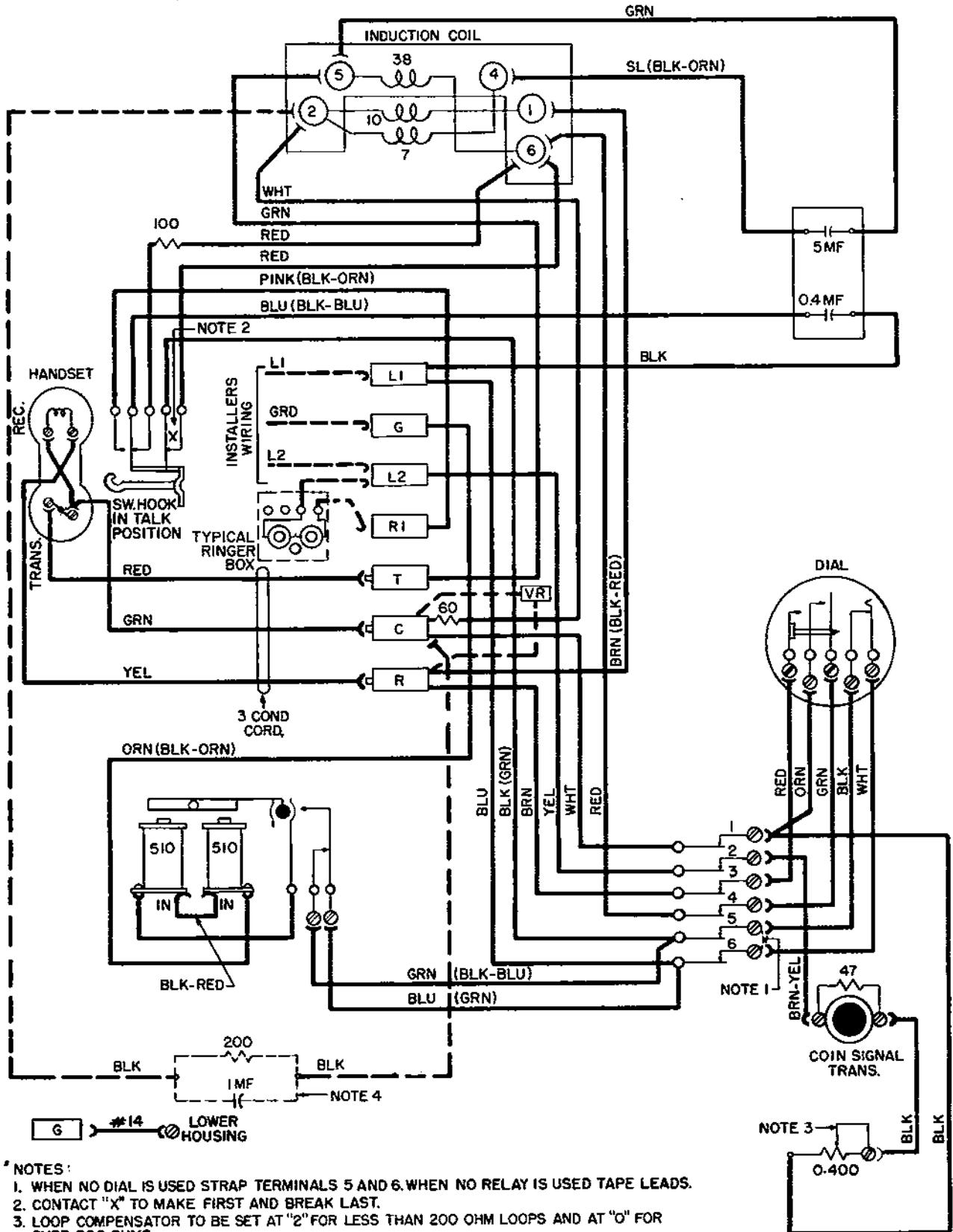

Figure 4. Type 62-55 Prepay Paystation Wiring Diagram



- NOTES:
1. WHEN NO DIAL IS USED STRAP TERMINALS 5 AND 6. WHEN NO RELAY IS USED TAPE LEADS.
  2. CONTACT "X" TO MAKE FIRST AND BREAK LAST.
  3. LOOP COMPENSATOR TO BE SET AT "2" FOR LESS THAN 200 OHM LOOPS AND AT "0" FOR OVER 200 OHMS.
  4. INSTALL SIDETONE BALANCING IMPEDANCE ON UNLOADED CABLE LOOPS OF OVER 200 OHMS PROVIDING ANY ADJACENT OPEN WIRE SECTION IS LESS THAN 200 OHMS.
  5. COLOR CODES THAT VARY FROM LPA 82 PAYSTATIONS AND APPEAR ON OLDER TYPE 82 PAYSTATION ARE GIVEN IN PARENS.

Figure 5. Type LPA 82 Prepay Paystation Wiring Diagram



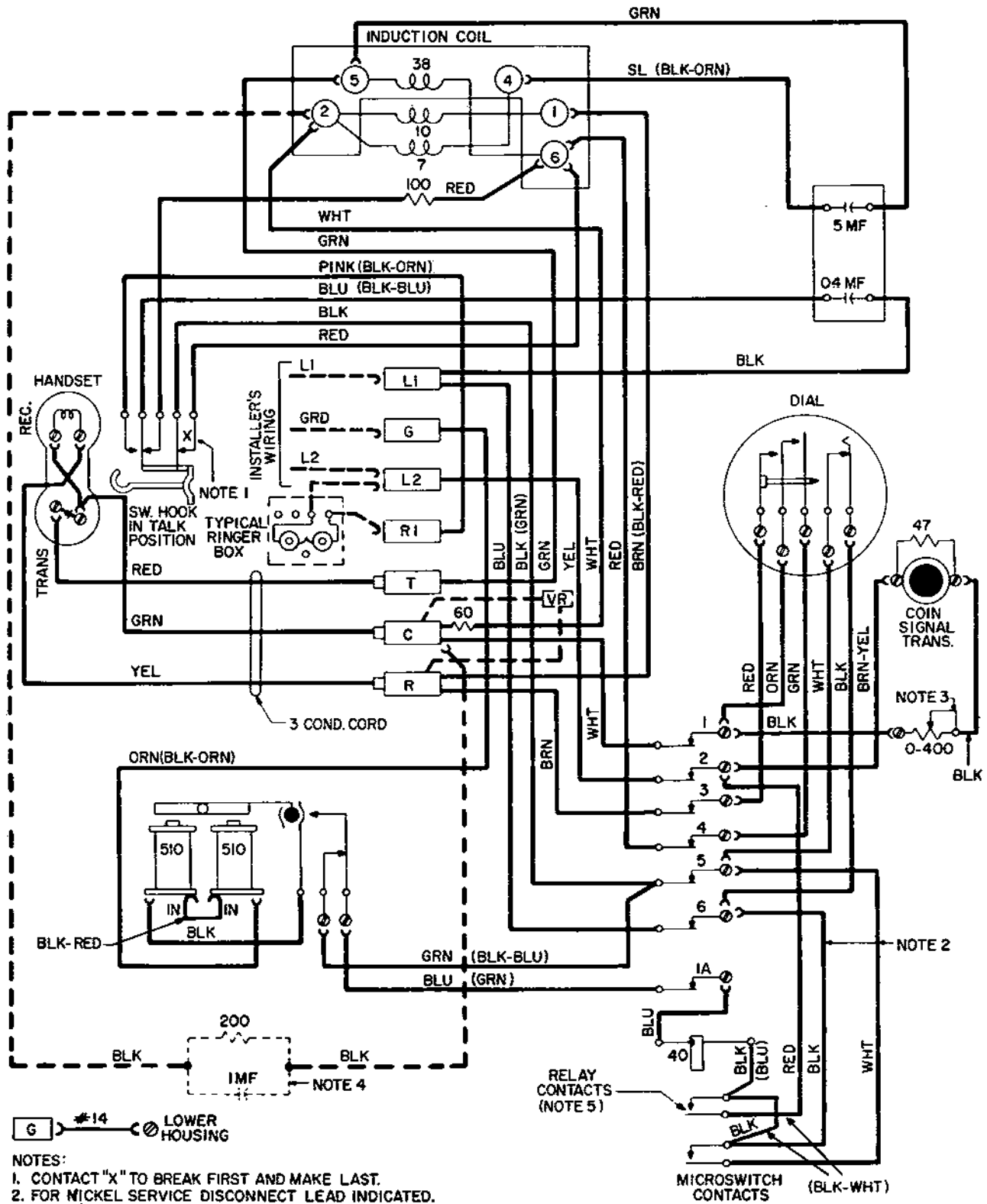

- NOTES:
1. CONTACT "X" TO BREAK FIRST AND MAKE LAST.
  2. FOR NICKEL SERVICE DISCONNECT LEAD INDICATED.
  3. LOOP COMPENSATOR TO BE SET AT "2" FOR LESS THAN 200 OHM LOOPS AND AT "0" FOR OVER 200 OHMS.
  4. INSTALL SIDETONE BALANCING IMPEDANCE ON UNLOADED CABLE LOOPS OF OVER 200 OHMS PROVIDING ANY ADJACENT OPEN WIRE SECTION IS LESS THAN 200 OHMS.
  5. ON LINE LOOPS LESS THAN 500 OHMS ISOLATE RELAY CONTACTS BY DISCONNECTING "RED" RELAY LEAD FROM JACK STRIP TERMINAL AND TAPING.
  6. COLOR CODES THAT VARY FROM LPA 82-55 PAYSTATIONS AND APPEAR ON OLDER TYPE 82-55 PAYSTATIONS ARE GIVEN IN PARENS.

Figure 6. Type LPA 82-55 Prepay Paystation Wiring Diagram

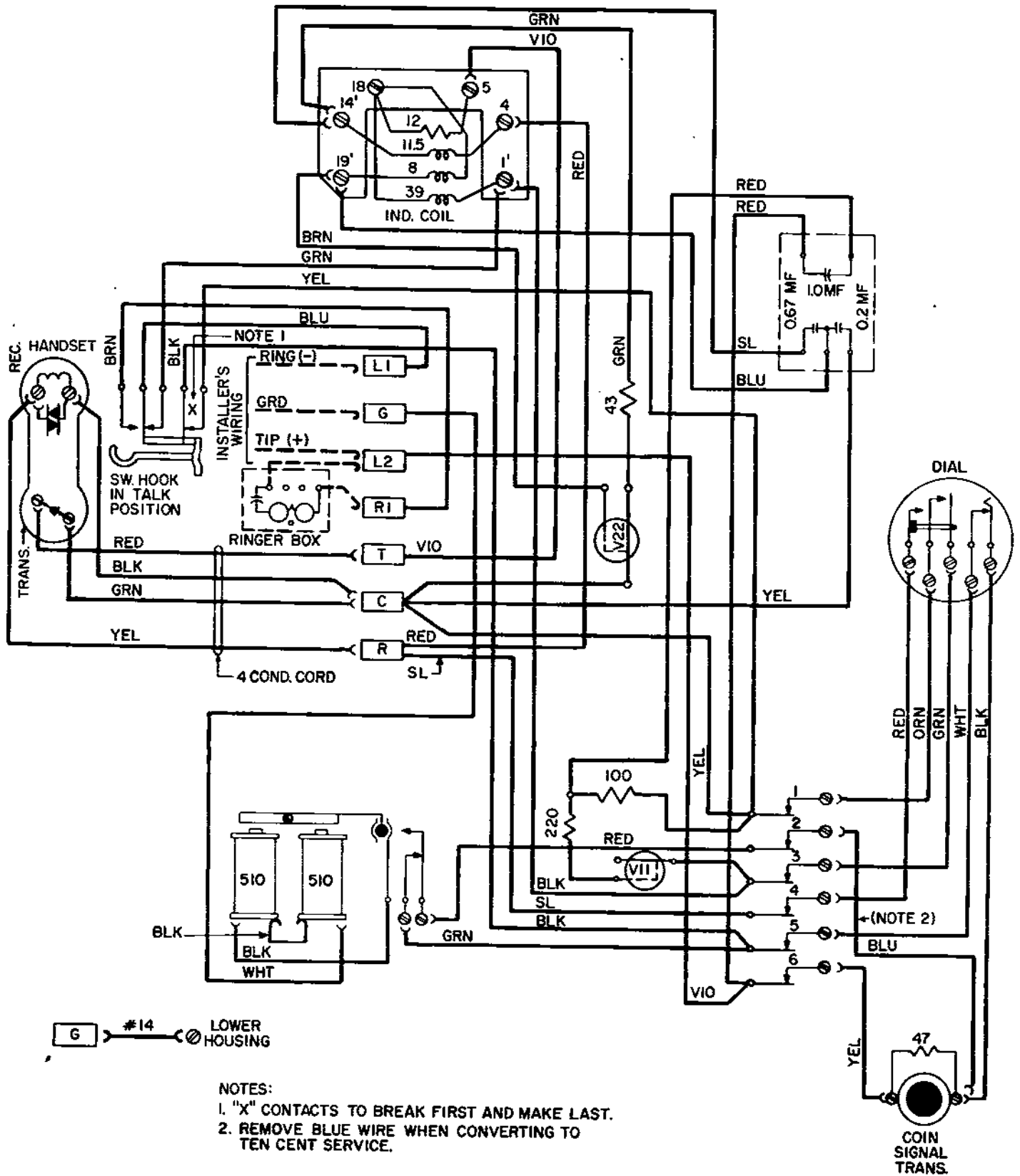

Figure 7. Type LPB 82 Prepay Paystation Wiring Diagram

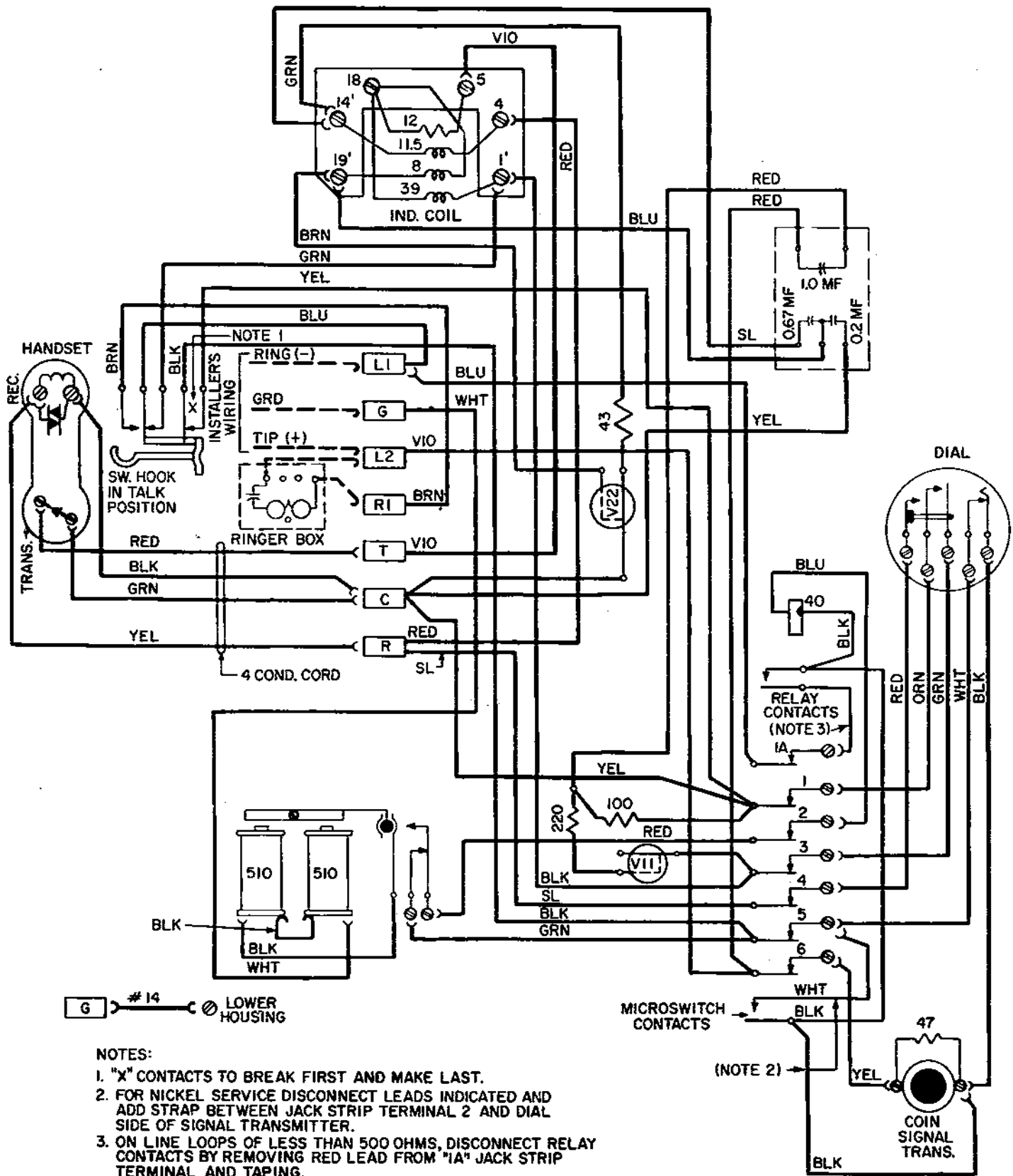
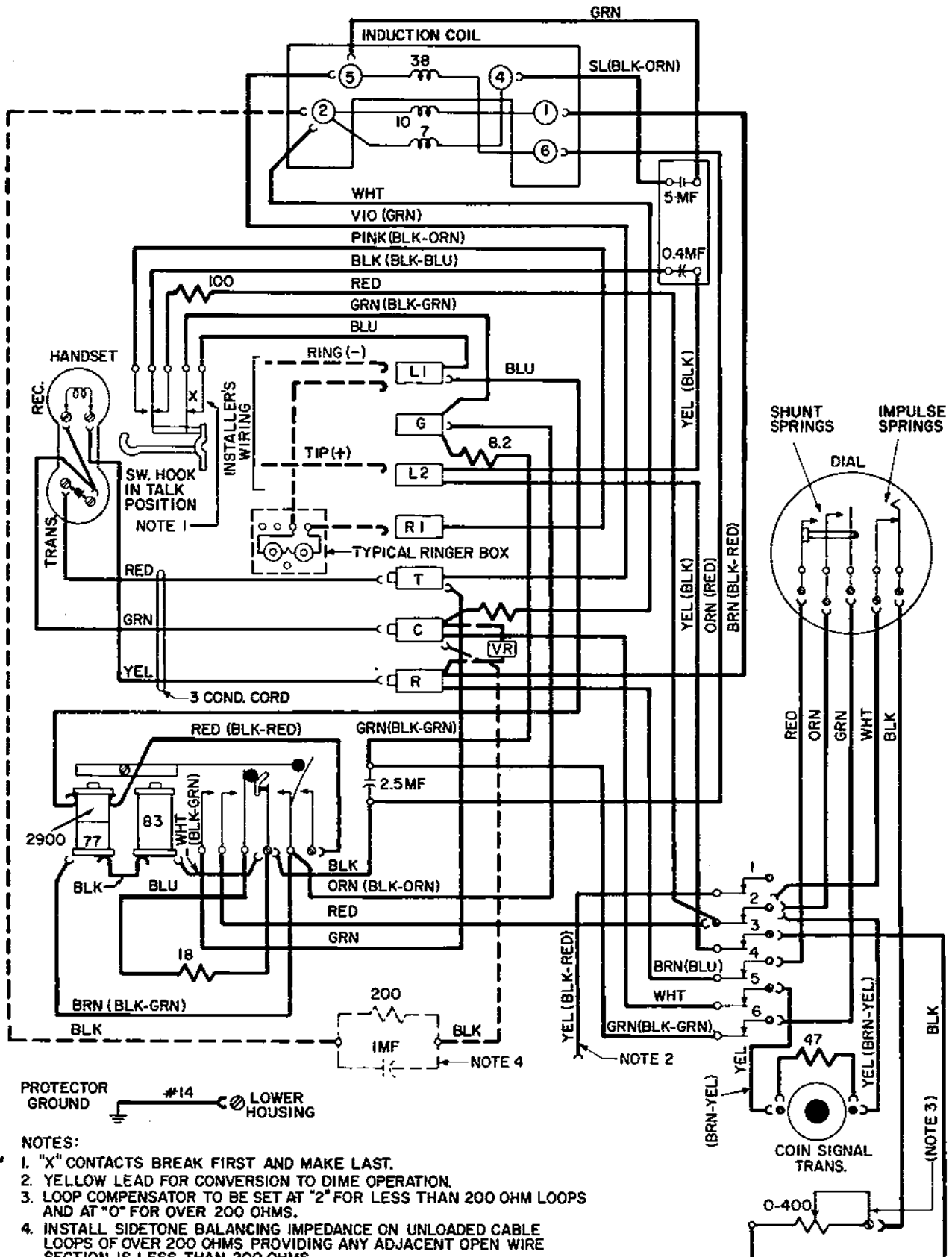

Figure 8. Type LPB 82-55 Prepay Paystation Wiring Diagram



NOTES:

1. "X" CONTACTS BREAK FIRST AND MAKE LAST.
2. YELLOW LEAD FOR CONVERSION TO DIME OPERATION.
3. LOOP COMPENSATOR TO BE SET AT "2" FOR LESS THAN 200 OHM LOOPS AND AT "0" FOR OVER 200 OHMS.
4. INSTALL SIDETONE BALANCING IMPEDANCE ON UNLOADED CABLE LOOPS OF OVER 200 OHMS PROVIDING ANY ADJACENT OPEN WIRE SECTION IS LESS THAN 200 OHMS.
5. COLOR CODES THAT VARY FROM LPA 86 PAYSTATIONS AND APPEAR ON OLD TYPE 86 PAYSTATIONS ARE GIVEN IN PARENS.

Figure 9. Type LPA 86 Semi-Postpay Paystation Wiring Diagram

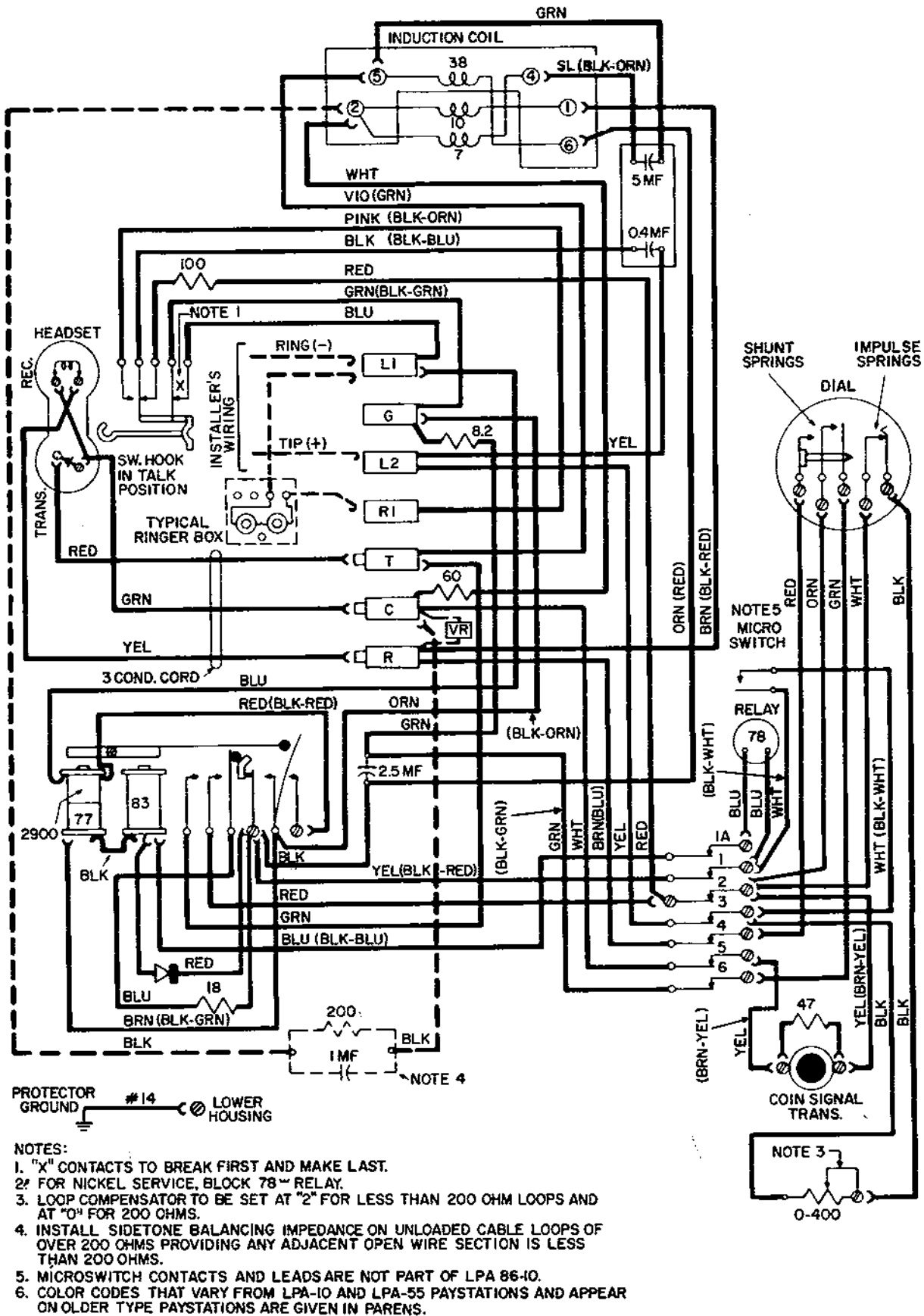

Figure 10. Types LPA 86-10 and LPA 86-55 Semi-Postpay Paystation Wiring Diagram

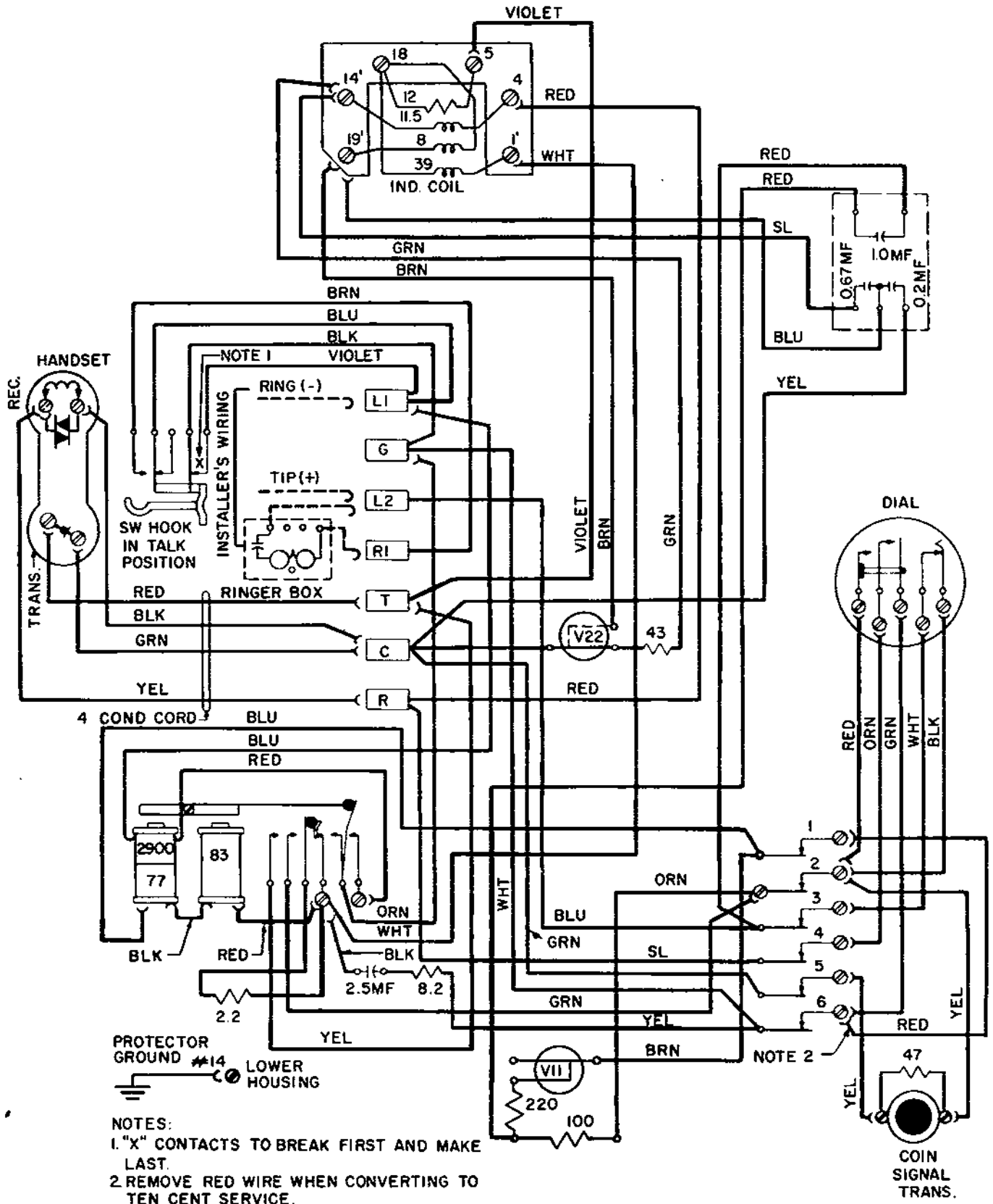

Figure 11. Type LPB 86 Semi-Postpay Paystation Wiring Diagram

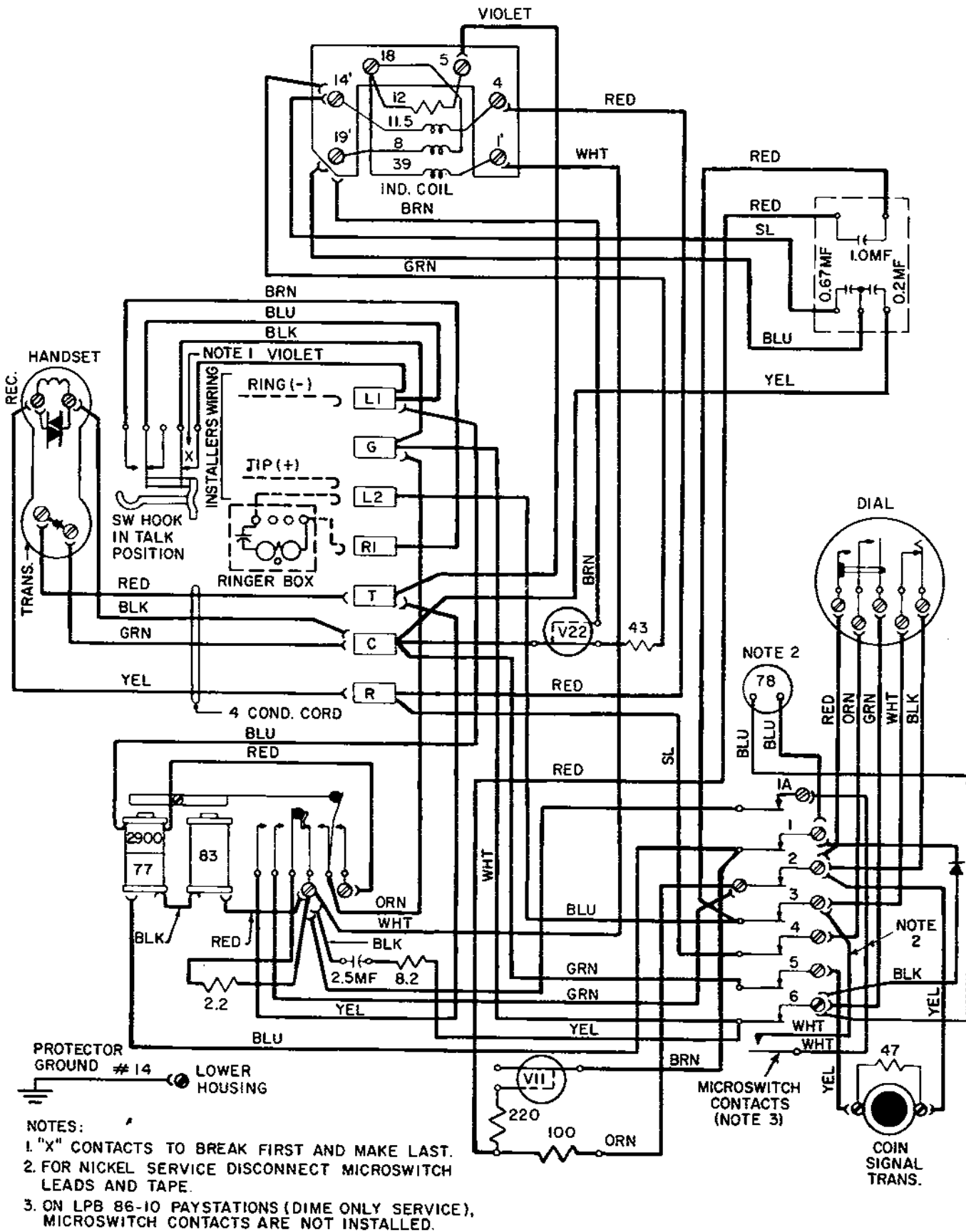
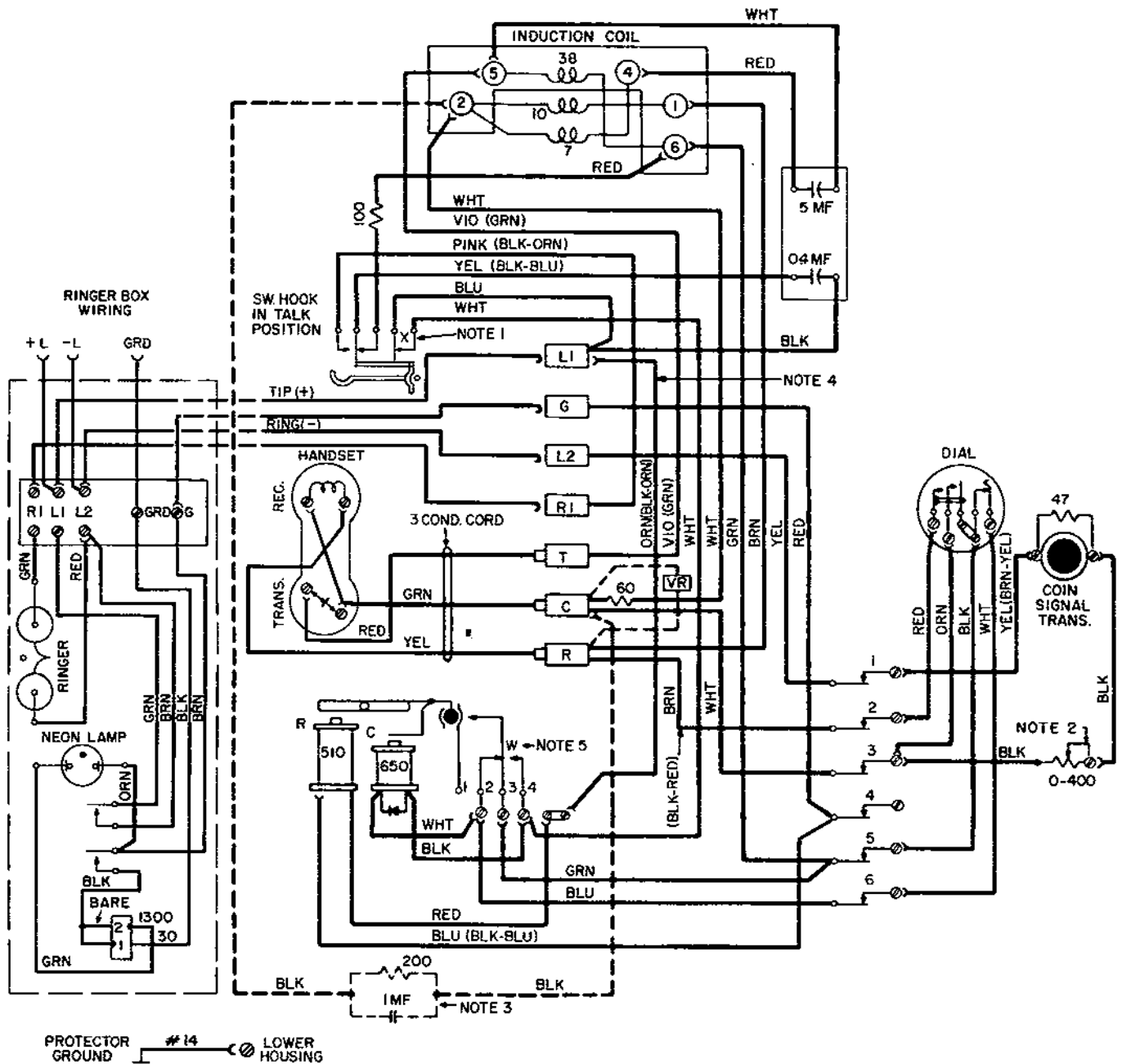

Figure 12. Types LPB 86-10 and LPB 86-55 Semi-Postpay Paystation Wiring Diagram



- NOTES:
1. "X" CONTACTS TO BREAK FIRST AND MAKE LAST.
  2. LOOP COMPENSATOR TO BE SET AT "2" FOR LESS THAN 200 OHM LOOPS AND AT "0" FOR OVER 200 OHMS.
  3. INSTALL SIDETONE BALANCING IMPEDANCE ON UNLOADED CABLE LOOPS OF OVER 200 OHMS PROVIDING ANY ADJACENT OPEN WIRE SECTION IS LESS THAN 200 OHMS.
  4. LEAD CONNECTED AS SHOWN IS FOR GRD. CONNECTED GEN. FOR BATTERY CONNECTED GEN., CONNECT THIS LEAD TO "L2" TERMINAL.
  5. "W" CONTACTS TO MAKE ONLY WHEN "C" OR "R" OPERATE.
  6. COLOR CODES THAT VARY FROM LPA-89 PAYSTATIONS AND APPEAR ON OLD TYPE 89 PAYSTATIONS ARE GIVEN IN PARENS.

Figure 13. Type LPA 89 Local Prepay Paystation Wiring Diagram



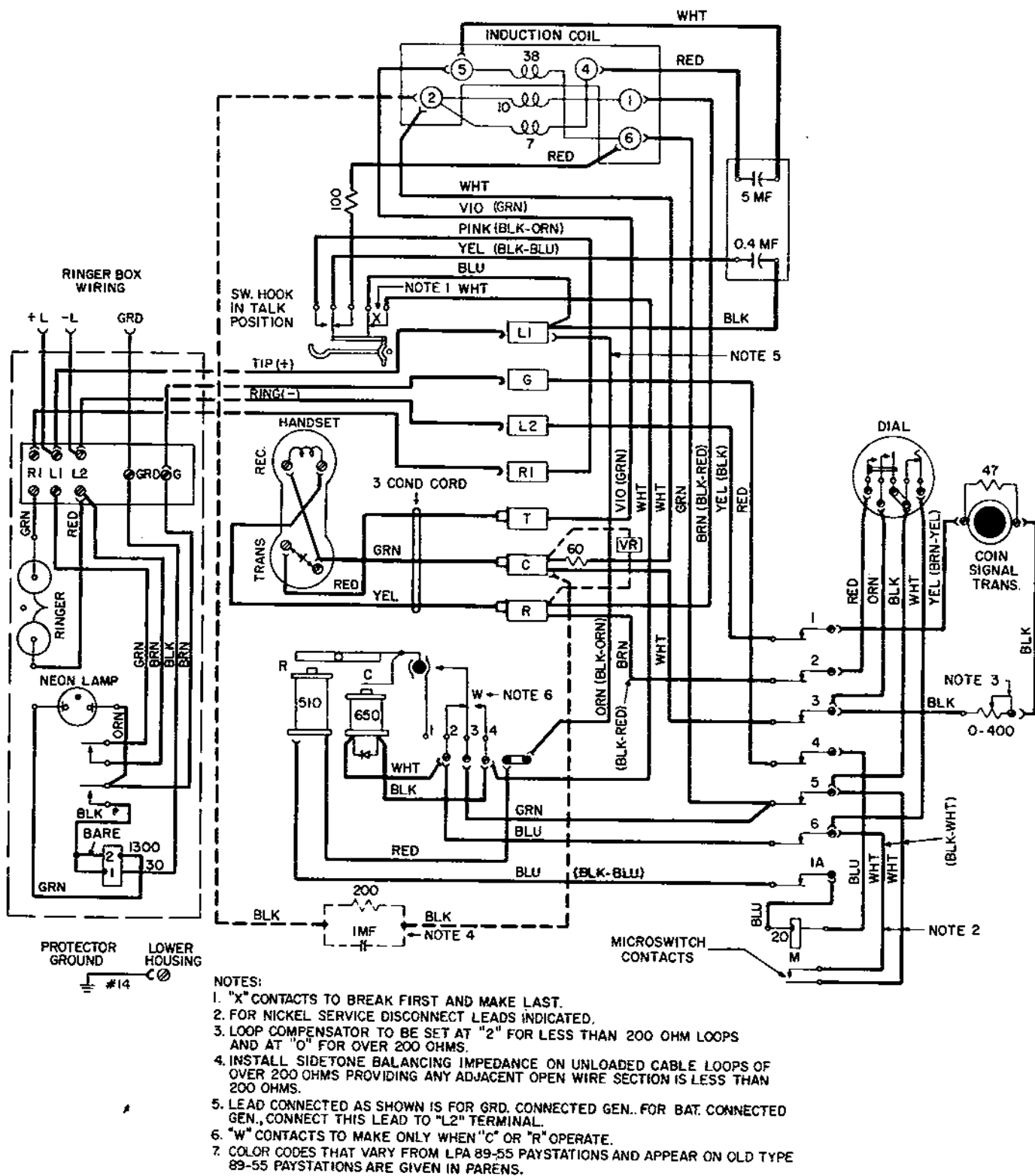

Figure 14. Type LPA 89-55 Local Prepay Paystation Wiring Diagram

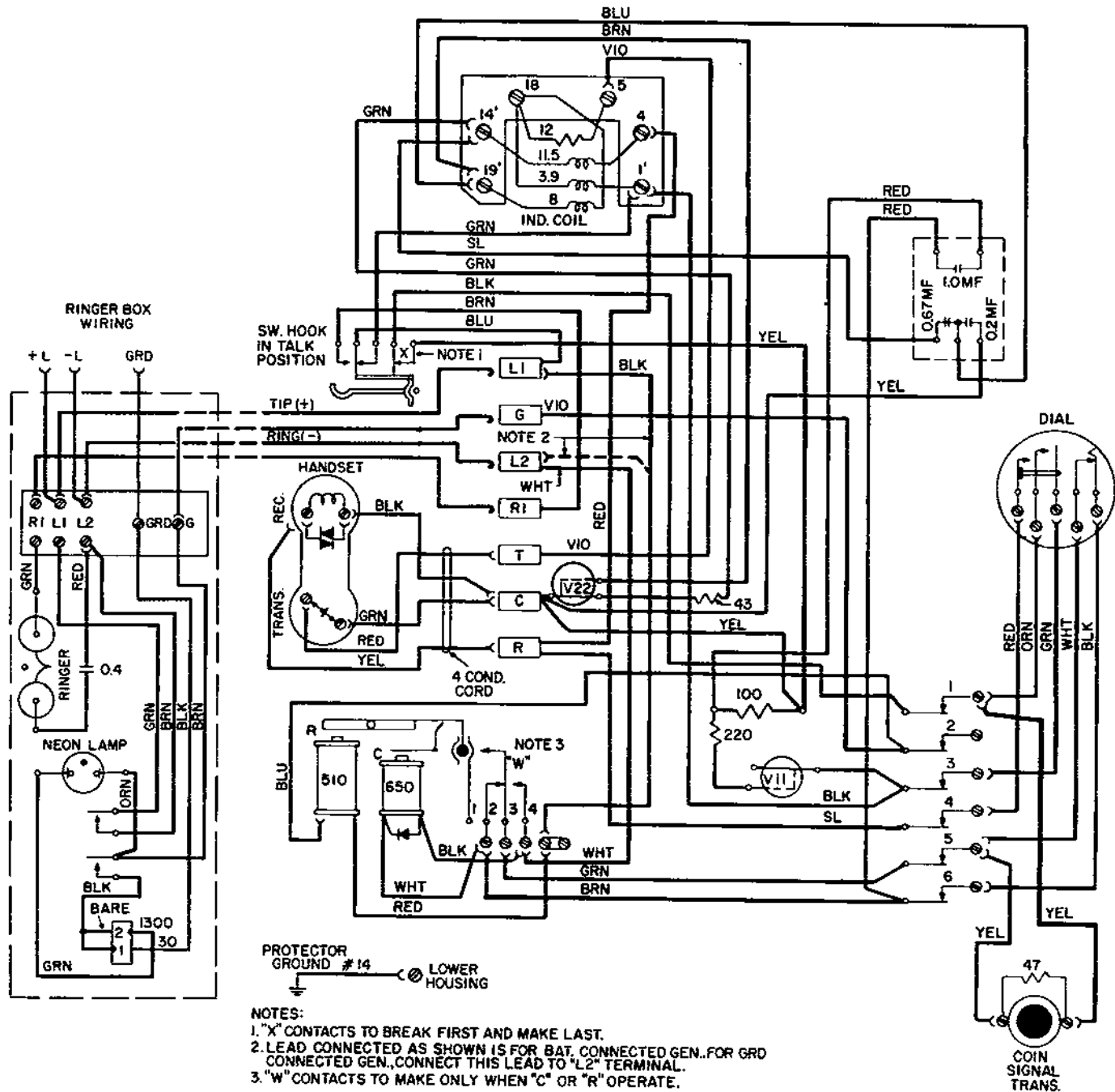

Figure 15. Type LPB 89 Local Prepay Paystation Wiring Diagram

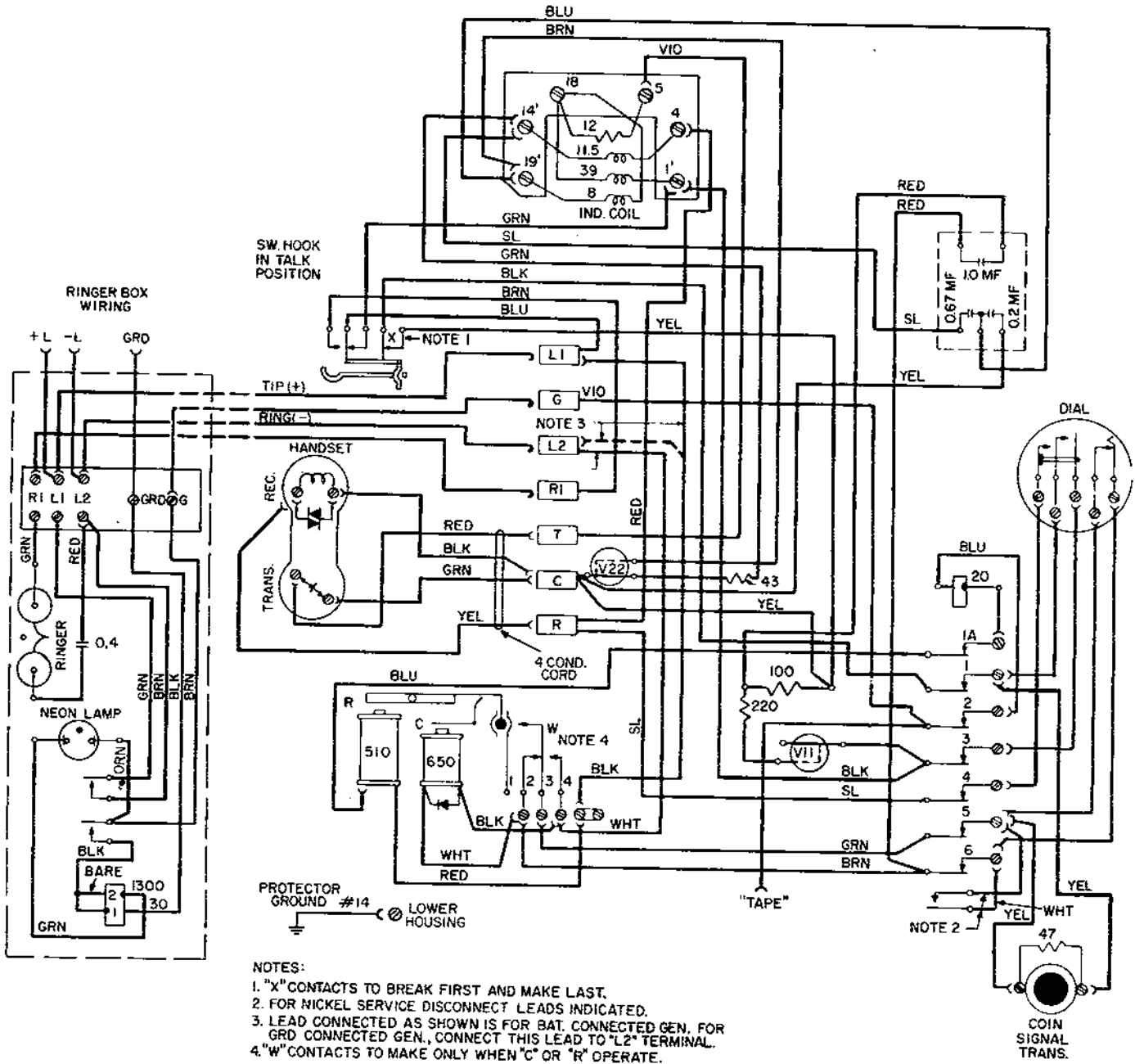

Figure 16. Type LPB 89-55 Local Prepay Paystation Wiring Diagram