

PACKAGING AND HANDLING

DISCONNECTED 1-TYPE TELEPHONE ANSWERING SETS

1.00 GENERAL

This section describes certain procedures to be followed when returning 1-type telephone answering sets to Western Electric Company.

2.00 REMOVAL AND PREPARATION FOR TRANSIT

- Use head-lock springs to secure both magnetic recording heads (Fig. 1).
- Secure carriage slide rod bracket to center drum support. Use cord or lacing twine and place the carriage in the extreme left-hand position (Fig. 2).
- Place corrugated paper fillers as shown in Fig. 2.
- Replace and fasten cover of answering set securely with setscrews in rear corners of base.
- Place answering set in the approved cardboard container (Fig. 3).

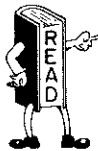

Absolutely nothing else should be put in the carton with the answering set. Scrap or other material of any sort should be transported separately.

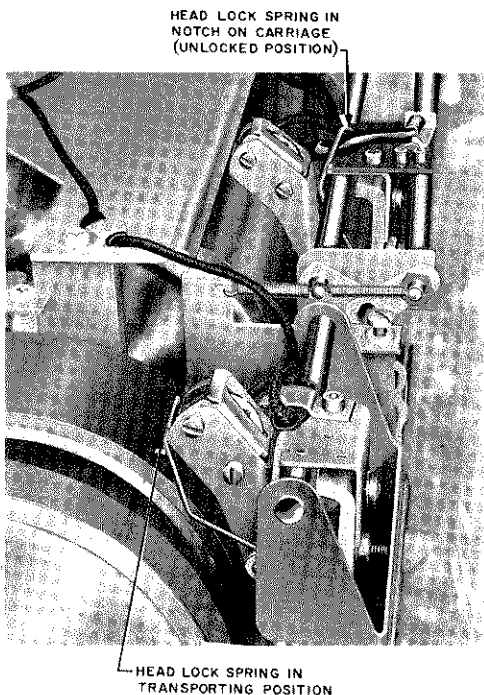

Fig. 1 — Magnetic Recording Heads

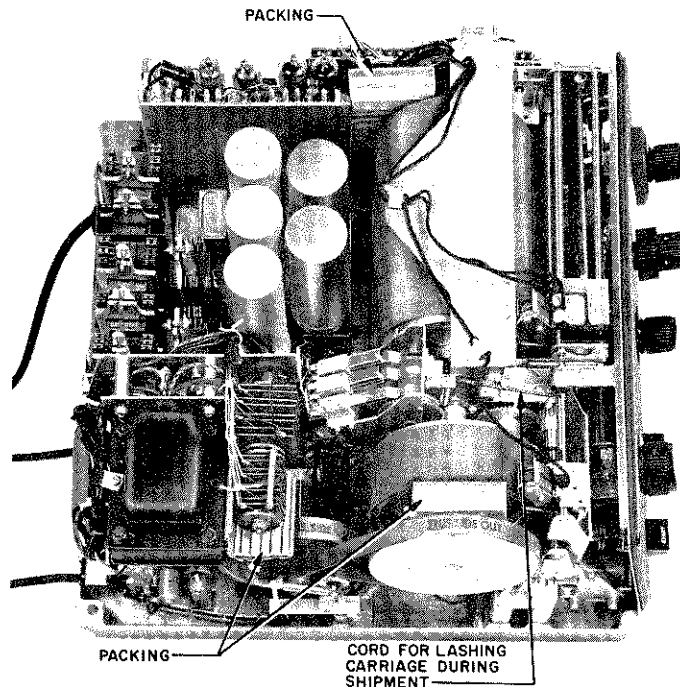

Fig. 2 — Telephone Answering Set

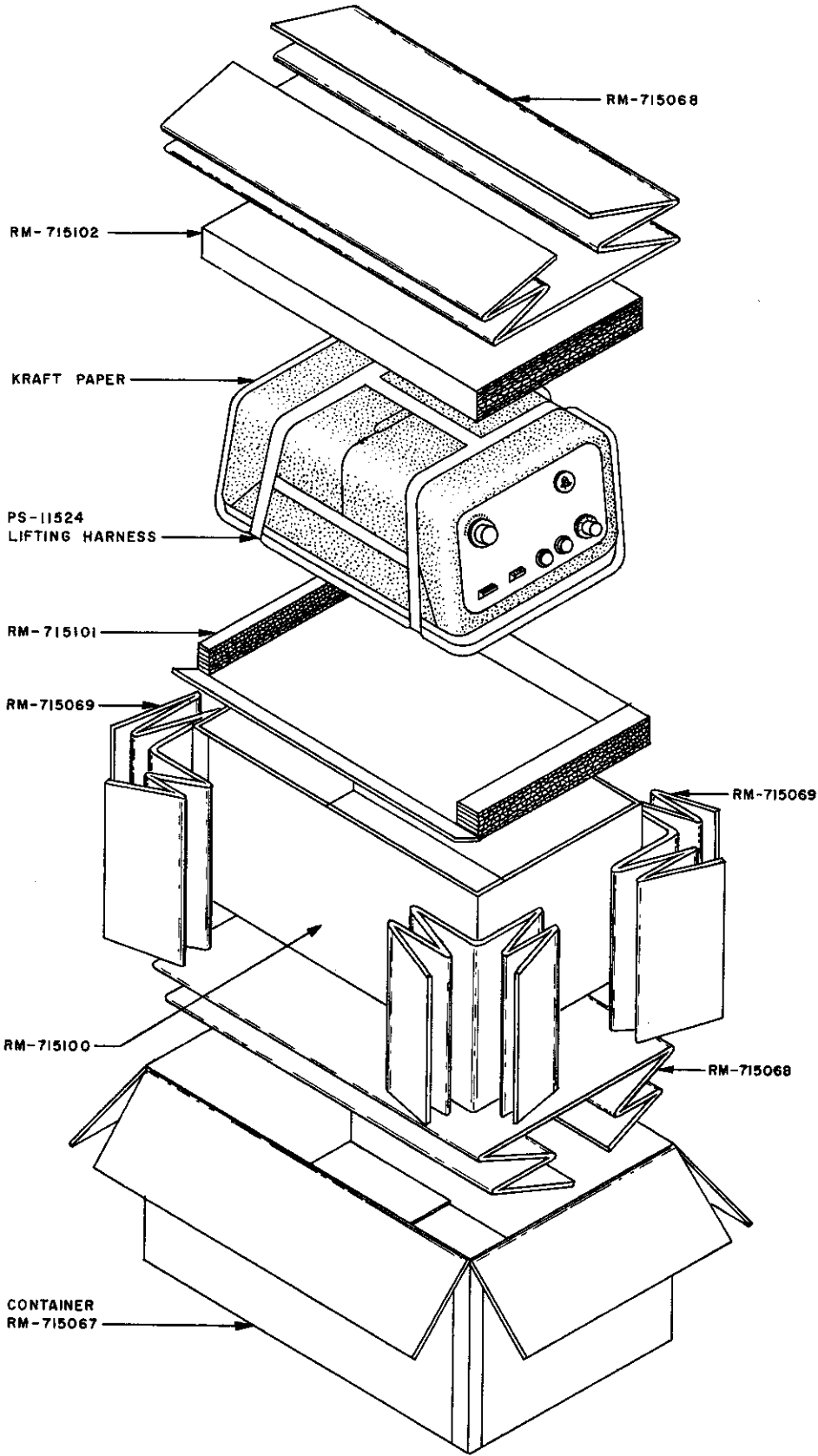

Fig. 3 - Packing Container